

**B.I.S. Symbols used for electrical accessories**

**Objectives:** At the end of this lesson you shall be able to

- interpret the various BIS symbols used in electrical wiring diagrams.

In electrotechnical engineering the symbols are used in layouts and wiring circuits to represent the electrical parts or the function of the circuit.

Since the drawing of the actual device is very laborious and would be drawn by each person differently, standardised symbols are used. With the help of the symbols, an electric

circuit can be represented easily and can be described precisely as well.

A few examples of standard symbols recommended by B.I.S. 2032 (different parts) used for wiring are given here.

**B.I.S. SYMBOLS FOR WIRING SCHEMES**







SI.No.	Description	Symbols used in the circuit diagram	Symbols used in layout
1	One-way switch, single pole		
2	One-way switch, two poles		
3	One-way switch, three poles		
4	Multi-position switch single pole		
5	Two-way switch		
6	Intermediate switch		
7	Push-button or bell-push		



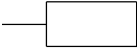
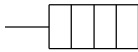



Sl.No.	Description	Symbols used in the circuit diagram	Symbols used in layout diagram
8	Socket outlets, 6A		
9	Socket outlets, 16A		
10	Lamp or outlet for lamp		
11	Fuse		
12	Bell		
13	Buzzer		
14	Earth point		
15	Circuit breaker		
16	Terminal strip		N.A
17	Link (closed)		N.A
18	Plug and socket (male and female)		N.A
19	Ceiling rose		N.A
	N.A: Not applicable		

The B.I.S. Symbols used in the wiring is given here.

ITEMS	SYMBOLS
<b>I Wiring</b>	
1 General wiring	
2 Wiring on the surface	
3 Wiring under the surface	
4 Wiring in conduit	
a Conduit on the surface	
b Conduit concealed	
The type of conduit may be indicated, if necessary.	
5 Wiring going upwards	
6 Wiring going downwards	
7 Wiring passing vertically through a room	
<b>II Fuse-boards</b>	
1 Lighting circuit fuse-boards	
a Main fuse-board without switches	
b Main fuse-board with switches	
c Distribution fuse-board without switches	
d Distribution fuse-board with switches	
2 Power circuit fuse-boards	
a Main fuse-board without switches	
b Main fuse-board with switches	
c Distribution fuse-board without switches	
d Distribution fuse-board with switches	
<b>III Switches and switch outlets</b>	
1 Single pole pull-switch	
2 Pendant switch	
<b>IV Socket outlets</b>	
1 Combined switch and socket outlet, 6A	

ITEMS	SYMBOLS
2 Combined switch and socket outlet, 16A	
3 Interlocking switch and socket outlet, 6A	
4 Interlocking switch and socket outlet 16A	
<b>V Lamps</b>	
1 Group of three 40 W lamps	
2 Lamp, mounted on a wall or light bracket	
3 Lamp, mounted on ceiling	
4 Counterweight lamp fixture	
5 Chain lamp fixture	
6 Pendant lamp fixture	
7 Lamp fixture with built-in switch	
8 Lamp fed from variable voltage supply	
9 Emergency lamp	
10 Panic lamp	
11 Bulk-head lamp	
12 Watertight light fitting	
13 Batten lamp-holder (Mounted on the wall)	
14 Projector	
15 Spotlight	
16 Floodlight	
17 Fluorescent lamp	
18 Group of three 40W fluorescent lamps	

ITEMS	SYMBOLS
<b>VI Electrical appliances</b>	
1 General If necessary, use designation to specify.	
2 Heater	
<b>VII Bells, buzzers and sirens</b>	
1 Siren	
2 Horn or hooter	
3 Indicator (at 'N' insert number of ways)	
<b>VIII Fans</b>	
1 Ceiling fan	
2 Bracket fan	

ITEMS	SYMBOLS
3 Exhaust fan	
4 Fan regulator	
<b>IX Telecommunication apparatus</b>	
1 Aerial	
2 Loudspeaker	
3 Radio receiving set	
4 Television receiving set	

## Wiring accessories, IE Rules

**Objectives:** At the end of this lesson you shall be able to

- classify, specify, identify and state the uses of the accessories employed in domestic wiring
- state the IE rules related to safety and electric supply.

**Electrical accessories:** An electrical domestic accessory is a basic part used in wiring either for protection and adjustment or for the control of the electrical circuits or for a combination of these functions.

**Rating of accessories:** The standard current ratings of the accessories are 6, 16 and 32 amps. The voltage rating is 240V AC as per B.I.S. 1293-1988.

**Mounting of accessories:** The accessories are designed to mount either on the surface or concealed (flush type).

**Surface mounting type:** Accessories are provided with a seating so that when mounted they project wholly above the surface on which they are mounted.

**Flush-mounting type:** These accessories are designed to mount behind or incorporated with a switch plate, the back of the plate being flush with the surface of the wall or switch box.

The electrical accessories used in wiring installation, are classified according to their uses.

- Controlling accessories
- Holding accessories
- Safety accessories
- Outlet accessories
- General accessories

## Types of switches according to their function and place of use

- 1 Single pole, one-way switch
- 2 Single pole, two-way switch
- 3 Intermediate switch
- 4 Bell-push or push-button switch
- 5 Pull or ceiling switch
- 6 Double pole switch (DP switches)
- 7 Iron clad double pole, (ICDP) switch.
- 8 Iron clad triple - pole (ICTP) switch.

Of the above 1,2,3,4 and 6 may be either surface mounting type or flush-mounting type.

**Single pole, one-way switch:** This is a two terminal device, capable of making and breaking a single circuit only. It is used for controlling light or fan or 6 amps socket. (Fig 1)

**Two-way switch:** This is a three terminal device capable of making or breaking two connections from a single position (Fig 2). These switches are used in staircase lighting where one lamp is controlled from two different places.

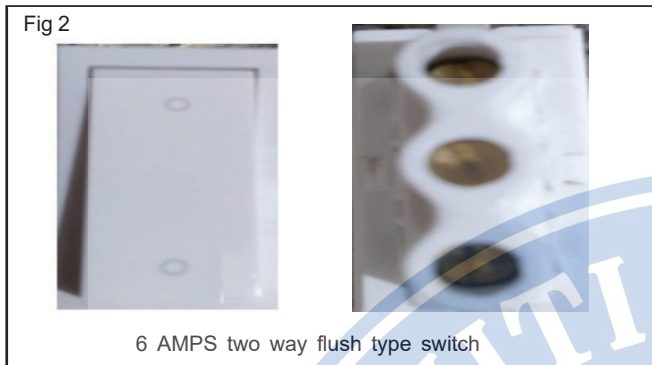
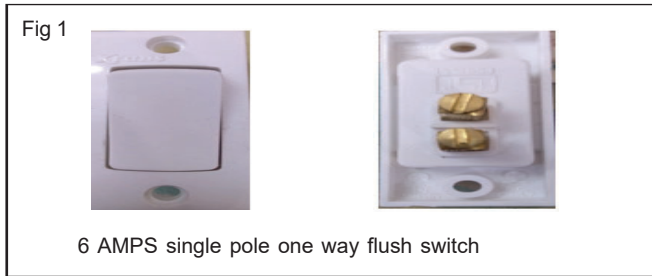

**Intermediate switch:** This is a four-terminal device capable of making or breaking two connections from two positions (Fig 3). This switch is used along with 2 way switches to control a lamp from three or more positions.

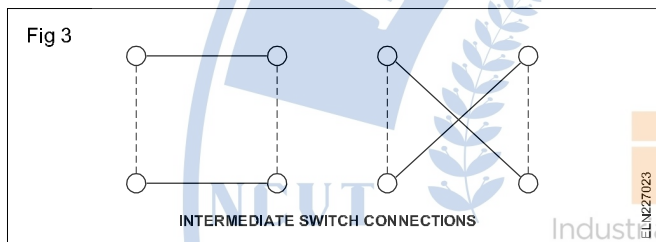

**Bell-push or push-button switch:** This is a two-terminal device having a spring-loaded button. When pushed it 'makes' the circuit temporarily and attains 'break' position when released.

**Iron - Clad Double pole (ICDP) main switch :** This switch is also referred to as DPIC switch and is mainly used for single phase domestic installations, to control the main supply. It controls phase and neutral of the supply simultaneously (Fig 4).

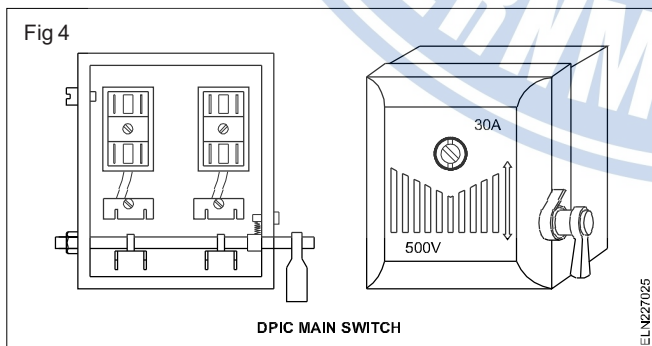

The current rating of the switch varies from 16 amps to 32 amperes.

**Iron - Clad Triple pole (ICTP) main switch:** This is also referred to as TPIC switch and is used in large domestic installation and also in 3-phase power circuits, the switch

consists of 3 fuse carriers, one for each phase. Neutral connection is also possible as some switches are provided with a neutral link inside the casing (Fig 5).

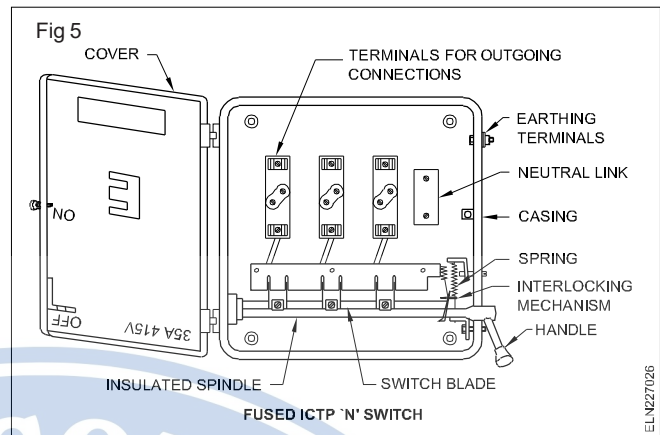

The current rating of the switch varies from 16 to 400 amps.

### Holding accessories

**Lamp-holders :** A lamp-holder is used to hold a lamp. Earlier, brass holders were most commonly used but nowadays these have been replaced by bakelite holders. These may contain solid or hollow spring contact terminals. Four types of lamp-holders are mainly available.

- Bayonet cap lamp-holders
- Screw type holders
- Edison screw type lamp-holders
- Goliath Edison screw type lamp-holders

**Bayonet cap (BC) lamp-holders:** In this type, the bulb is fitted into the slot, and is held in position by means of two pins in the lamp cap. It has solid or hollow spring contact terminals, and the supply mains through the switch are connected to these contacts. In BC types there are two grooves on the circular construction of all types of holders.

**Pendent lamp-holders:** This holder (Fig 6) is used in places where the lamps are required in a hanging position. These holders are made of either brass or bakelite. An exploded view of this holder shows the parts of the holder. These holders are used along with ceiling roses for suspending the lamps from the ceiling.

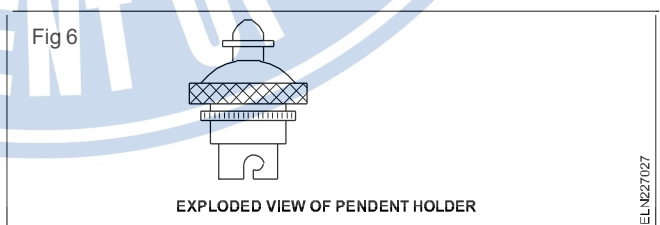

**Batten lamp-holders:** The straight batten holder (Fig 7a) is used on a flat surface on the round block, wooden board etc. These holders are made of either brass or bakelite.

**Angle holders:** The angle bottom holder, (Fig 7b) is to hold the lamp in a particular angle. These are made of either brass or bakelite. These are used for advertising boards, window display, kitchens etc.

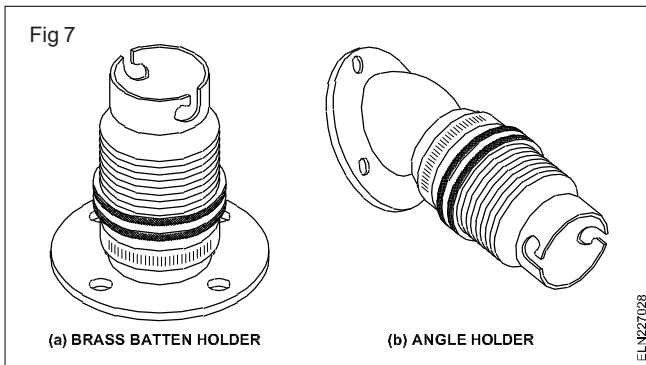

**Edison screw-type lamp-holders:** In this type, the holder is provided with inner screw threads and the lamp is fitted in it by screwing. It has a centre contact which is connected to the live wire and the screwed cap is connected to the neutral wire.

For lamps with wattage above 200W and not exceeding 300W, Edison screw-type holders are used. (Fig 8).

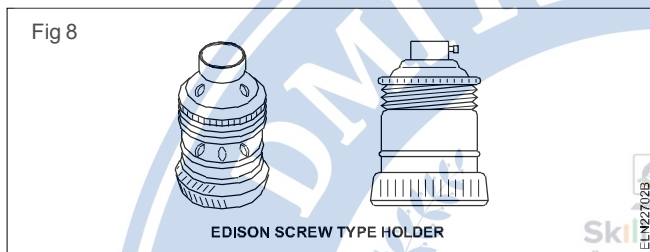

**Goliath Edison screw (GES) type holders** (Fig 9): The cover of this type of holder is made of porcelain. Such holders are used in studios, headlights, floodlights, focussing lights etc.

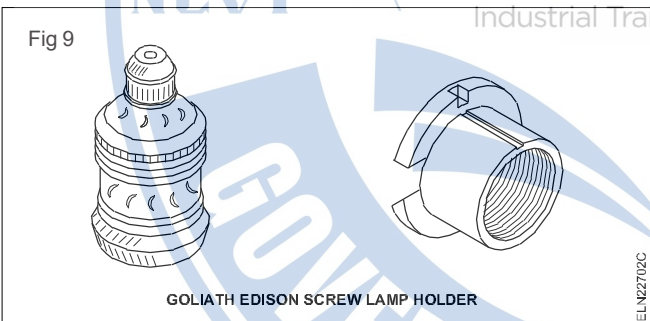

These holders are used for more than 300W lamps.

**Specification of a lamp-holder:** While specifying the lamp-holders, the type of material used for construction, type of gripping, type of mounting, working current and voltages should also be specified.

**Socket outlet current rating:** The standard ratings shall be 6, 16 and 32 amperes and 240 volts.

**Two-pin socket:** This socket is rated as 6A, 250V, having only two pins without earth connection. These are suitable only for double insulated appliances (having PVC or insulated body).

**Two-pin plug top:** It is used for taking the supply from the socket. It has got two pins of the same size.

**Three-pin socket:** This type of socket is suitable for light and power circuits. These sockets are rated as 6A, 250V or 16A, 250V, and are available as surface-mounting type

and flush type (Fig 10). There are three terminals marked as Line (L) Neutral (N) and Earth (E).

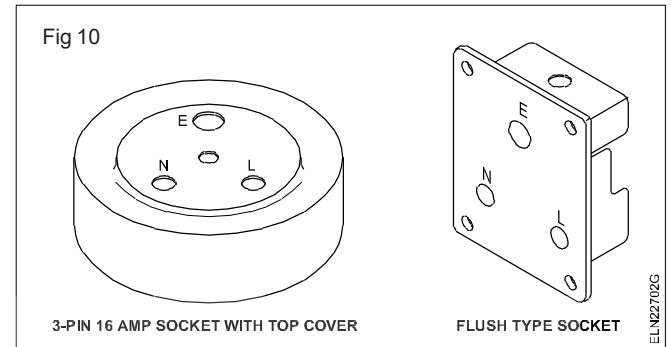

**Three-pin plug top :** It is used for taking the supply from the socket. It has three pins. Two are similar in size and the third one is bigger and longer which is for earth (Fig 11). These are also rated as 6A, 250V or 16A, 250V. These are made of bakelite, PVC materials.

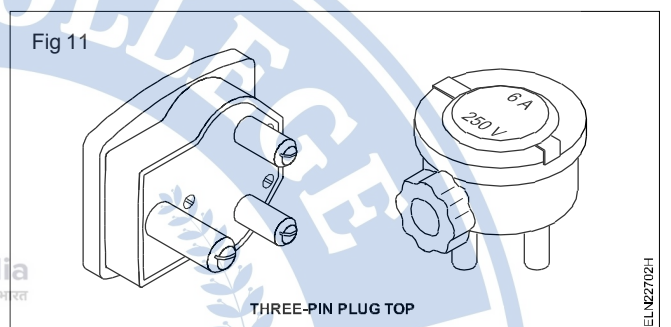

**General accessories :** Some accessories are used for general and special purposes such as:

- appliance connectors (or) iron connectors
- adapters
- ceiling roses
  - a two-plate
  - b three-plate
- connectors
- distribution board
- neutral links.

**Appliance connectors or iron connectors :** These are used as female connectors to supply current to electric kettles, electric iron, hotplate, heaters etc. It is made of bakelite or porcelain. These are rated as 16A, 250V (Fig 12).

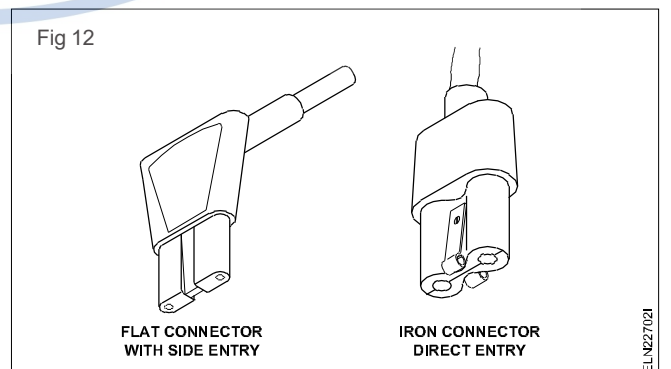

**Adaptor** (Fig 13): They are used for taking supply from a lamp holder for small appliances. They are made out of bakelite. They are available in ratings up to 6 A 250 V.

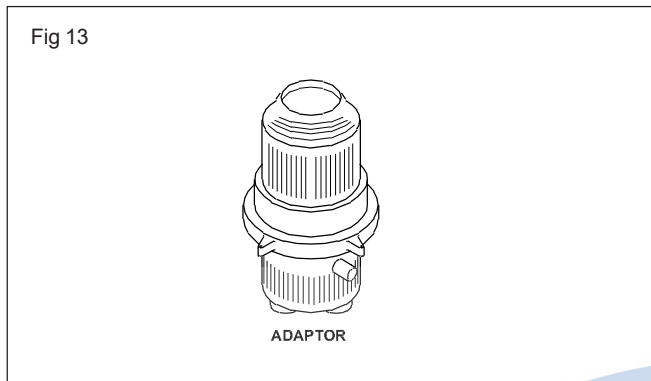

**Ceiling roses:** Ceiling roses are used to provide tapping points from the wiring for supplying power to fans, pendent-holders, tube lights etc. Normally flexible wires are used for tapping from the ceiling roses.

**Two-plate ceiling rose** (Fig 14a & b): This is made of bakelite and it has 2 terminals (phase & neutral) which are separated from each other by a bakelite bridge. The two-plate ceiling rose is used for 6A, 250V current capacity.

**Three-plate ceiling rose:** This type of ceiling rose has 3 terminals which are separated from each other by a bakelite bridge. It can be used for two purposes. (Fig 14c)

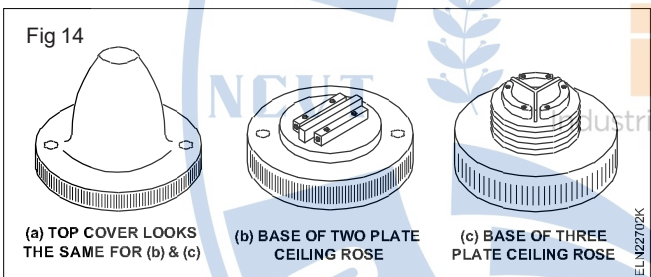

- Bunch light control
- To provide tapping for phase wire (Fig 15).

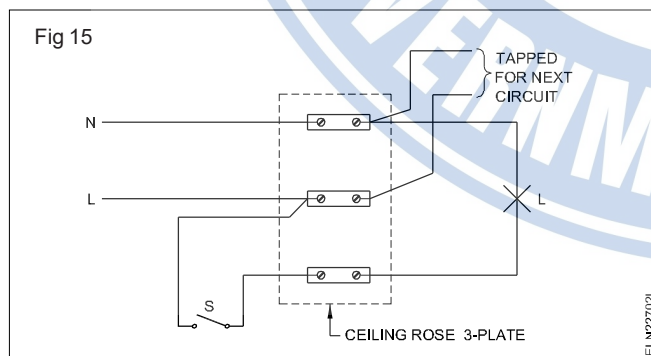

These ceiling roses are available in the rating of 6A, 250V

**Distribution board** (Fig 16): These are used where the total load is high and is to be divided into a number of circuits. These are used where the load is more than 800W. The number of fuses in the board is according to the number of circuits, and a neutral link is also provided so that the neutral wire can be taken for different circuits. All these

branch fuses are enclosed in a metal box. These boards are available as two-way, three-way, 4,6,12-way types.

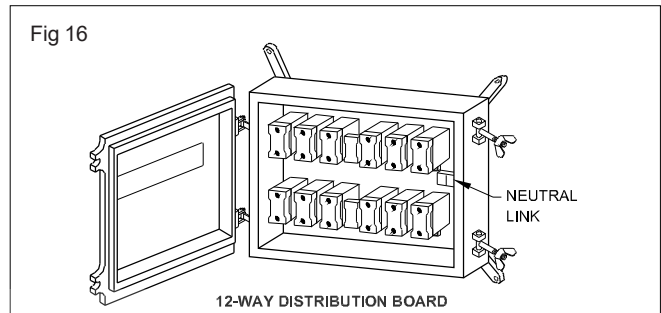

**Neutral link:** In a three-phase system of wiring installations, the phases are controlled through switches, and the neutral is tapped through a link called neutral link. (Fig 17). The ratings are 16A, 32A, 63A, 100A neutral link.

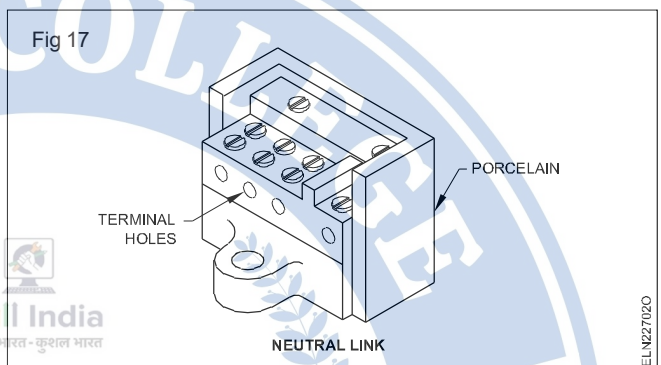

The accessories' rating shall be 240V and 6 or 16 amps from the year 1991, instead of 250V and 5 or 15 amps as per BIS 1293-1988.

**Toggle switches** (Fig 18)

It is an electric switch operated by means of a projecting lever that can be moved upward and downward and is also called as snap switches .

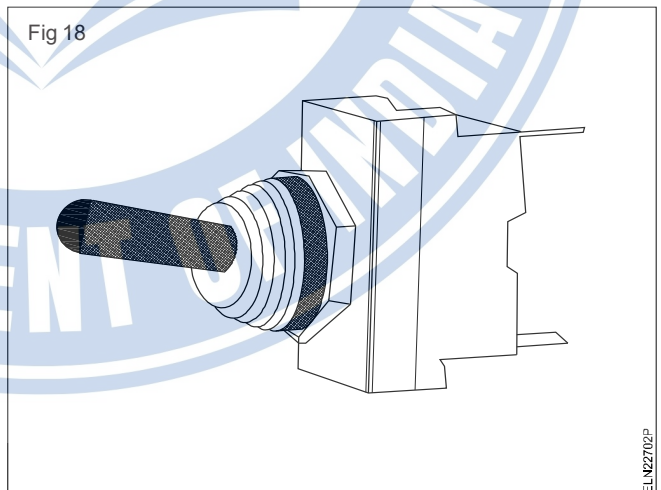

**Modular switches** (Fig 19)

The latest version of modular switch of different sizes and colours along with sockets combined and switches with indicators are available in market

**Indian Electricity Rules - Safety Requirements**

The IE rules 1956 was made under sections 37 of Indian Electricity Act 1910. Now it is redefined after the enactment

of the Electricity Act 2003. The Central Electricity Authority (measures relating to safety and electric supply) Regulation (CEAR) 2010 which came into effect from 20th September 2010, in place of Indian Electricity Rules 1956.



**SAFETY RULES:** Among safety rules, the following are important and indeed requires attention. Every rule in the Indian Electricity Rules 1956 is related either directly or indirectly to safety.

**Rule 32:** Switches shall be on the live conductor. No cutout, link or switch other than gang switch shall be inserted in the neutral conductor. Code of Practice of wiring shall be followed while marking the conductors.

**Rule 50:** Energy shall not be supplied, transformed, converted or used unless the following provisions are observed. A suitable linked switch or circuit breaker is erected at the secondary side of the transformer. Every circuit is protected by a suitable cut-out. Supply to each motor or group of motors is controlled by a linked switch or circuit breaker. Adequate precautions are taken to ensure that no live parts are exposed.

#### Special provisions in respect of high and extra high voltage installations

**Rule 63:** Approval of Inspector is necessary before energising any high voltage installations.

**Rule 65:** The installation must be subjected to the prescribed testing before energizing.

**Rule 66:** Conductors shall be enclosed in a metallic covering and suitable circuit breakers shall be provided to protect the equipment from overloading.

**Rule 68:** In case of outdoor type of sub-station a metallic fencing of not less than 1.8 m height shall be erected around the transformer.

#### Provisions in terms of OH line

**Rule 77:** Clearance of lowest conductor above ground across street.

- Low and Medium Voltage lines - 5.8 m.
- High voltage Lines - 6.1 m.

- Clearance of lowest conductor above ground along a street. Low and Medium Voltage lines - 5.5 m.
- High voltage lines - 5.8 m.
- Clearance of lowest conductor above ground other than along or across the street. Low, Medium and High Voltage lines upto 11 KV if bare - 4.6m .
- Low, Medium and High upto and including 11KV, if insulated - 4.0m.
- High Voltage above 11 KV - 5.2 m.

**Rule 79:** Clearance of low and medium voltage lines from building,

- Vertical Clearance - 2.5 m.
- Horizontal clearance - 1.2 m.

**Rule 80:** Clearance from building of high and extra high voltage. Vertical Clearance High Voltage upto 33KV - 3.7m.

- Extra High Voltage above 33KV - 3.7 m, plus 0.3 m for every 33KV part there of.
- Clearance from building of high and extra high voltage - Pitched Roof . Vertical Clearance upto 11KV - 1.2m.
- Above 11KV upto 33KV - 2.2 m.
- Above 33KV - 2m. plus 0.3m for every 33KV part there of.

**Rule 85:** Maximum interval between supports. It shall not exceed 65 m except by prior approval of inspector.

#### Indian electricity rules regarding to internal wiring:

- 1 The minimum size of conductor used in domestic wiring must not be of size less than 1/1.12mm in copper or 1/1.40mm (1.5mm) in aluminium wire.
- 2 For flexible wires the minimum size is 14/0.193mm.
- 3 The height at which meter board, Main switch board are to be fitted 1.5 meters from ground level.
- 4 The casing will be run at a height of 3.0 meters from the ground level.
- 5 The light brackets should be fixed at a height of 2 to 2.5 meters from ground level.
- 6 The maximum number of points in a sub circuit is 10.
- 7 The maximum load in a sub circuit is 800W.

#### I.E. Rules regarding - Voltage drop concept:

- 1 **I.E. Rule 48:** The insulation resistance between the wiring of an installation and earth should be of such a value that the leakage current may not exceed 1/50000 the part or 0.02 percent of the F.L. current.
- 2 The permissible voltage drop in a lighting circuit is 2% of the supply voltage plus one volt.
- 3 The maximum permissible voltage drop in a power industrial circuit should not be more than 5% of the declared supply voltage.
- 4 The insulation resistance of any wiring installation should not be less than  $1M\Omega$  .

- The earth resistance should not exceed the value of one ohm.

#### I.E. Rules regarding to power wiring:

- In a power sub circuit the load is normally restricted to 3000 watts and number of outlets to two in each sub circuit.
- All equipment used in power wiring shall be iron clad construction and wiring shall be of the armoured cable or conduit type.
- The length of flexible conduit used for connections between the terminal boxes of motors and starters,

switches and motors shall not exceed 1.25 meters

- Every motor, regardless of its size shall be provided with a switch fuse placed near it.
- The minimum cross-sectional area of conductor, that can be used for power wiring of 1.25 mm for copper conductor cables and 1.50 mm for Aluminium conductor cables (refer ISI recommendations). Hence VIR or PVC cables of size lower than 3/0.915 mm copper or 1/1.80 mm Aluminium can not be used for motor wiring.

## Circuit Breaker (CB) - Miniature Circuit Breaker (MCB)- Moulded Case Circuit Breaker (MCCB)

**Objectives:** At the end of this lesson you shall be able to

- explain the types, working principle and parts of a miniature circuit breaker.
- state the advantages and disadvantages of MCB
- state the categories and applications of MCBs
- state the application, advantage and disadvantage of MCCBs.

### Circuit Breaker

A circuit breaker is a mechanical switching device capable of making, carrying and breaking the currents under normal condition and breaking the currents under abnormal conditions like a short circuit.

#### Miniature circuit breaker (MCB)

A miniature circuit breaker is a compact mechanical device for making and breaking a circuit both in normal condition and in abnormal conditions such as those of over current and short circuit.

#### Types of MCB's

MCBs are manufactured with three different principles of operation namely

- Thermal Magnetic
- Magnetic hydraulic and
- Assisted bimetallic

Out of three MCB's thermal magnetic MCB is discussed below

#### Thermal magnetic MCB

The switching mechanism is housed in a moulded housing with phenolic moulded high mechanically strong switching dolly. This type of MCB is also provided with bimetallic overload release (Fig 1).

The electric current gets through two contact tips one each on moving and fixed contact of silver graphite.

An arcing chamber incorporating de-ionising arc chutes for control and quick suppression of the arc is provided in the gap between two contacts. It has a ribbed opening closed by metal grid which allows ventilation and escape of gases.

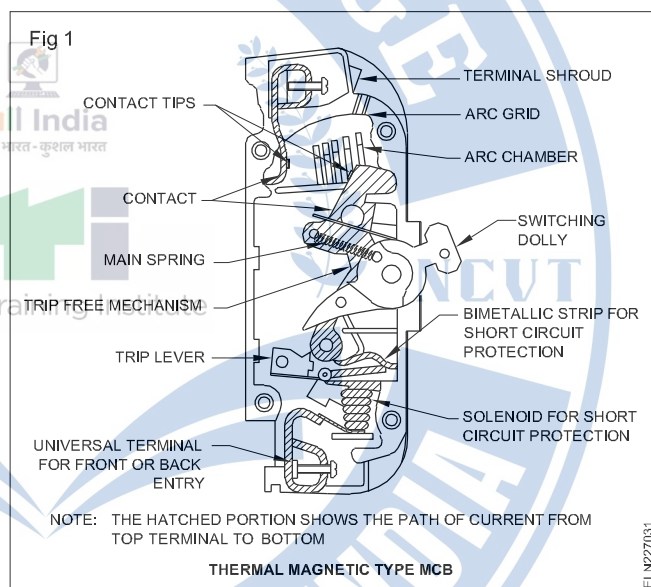

For protection against over-load and short circuit, MCB's have thermal magnetic release unit. The overload is taken care of by bimetallic strip, short circuit currents and over loads of more than 100% are taken care by solenoid.

#### Working

The bimetallic strip when flexing due to temperature rise caused by increasing normal rated current beyond 130% rotates a trip lever carrying an armature to which it is brought into field of a solenoid. The solenoid is designed to attract the armature to full position at about 700% overload or instantaneous short circuit current.

For initial portion of current wise (130% to 400%) tripping of circuit breaker is due to thermal action, between 400 to 700% tripping is due to combined thermal and magnetic action and beyond 700% due to fully magnetic action.

## Categories of MCBs

Certain manufacturers like Indo Kopp manufacture the MCBs in three different categories namely 'L' series, 'G' series, and 'DC' series.

### 'L' series MCBs

'L' series MCBs are designed to protect circuits with resistive loads. They are ideal for protection of equipment like Geysers, ovens and general lighting systems.

### 'G' series MCBs

'G' series MCBs are designed to protect circuits with inductive loads. G series MCBs are suitable for protection of motors, air conditioners, hand tools, halogen lamps etc.,

### 'DC' series MCBs

'DC' series MCBs are suitable for voltage upto 220V DC and have a breaking capacity up to 6kA.

The tripping characteristics are similar to 'L' and 'G' series. They find extensive application in DC controls, locomotives, diesel generator sets etc.,

### Advantages of MCB

- 1 Tripping characteristic setting can be done during manufacture and it cannot be altered.
- 2 They will trip for a sustained overload but not for transient overload.
- 3 Faulty circuit is easily identified.
- 4 Supply can be quickly restored.
- 5 Tamperproof.
- 6 Multiple units are available.

### Disadvantages

- 1 Expensive.
- 2 More mechanically moving parts.
- 3 They require regular testing to ensure satisfactory operation.

- 4 Their characteristics are affected by the ambient temperature.

## Moulded Case Circuit Breakers (MCCB)

Moulded case circuit breakers are similar to thermo magnetic type MCBs except that these are available in higher ratings of 100 to 800amp at 500V 3-phase.

In MCCB, thermal and magnetic releases are adjustable. A shunt release is also incorporated for remote tripping and interlocking at MCCB. MCCBs are provided with under voltages release. There are two types of MCCB.

- 1 Thermal magnetic type.
- 2 Fully magnetic type (Fig 2).

### Advantages of MCCB

- 1 MCCBs occupy much less space in comparison to fuse switch units.
- 2 MCCBs provide equal amount of protection against high faults as switch gears having HRC fuses.

### Disadvantages

- 1 MCCBs are much costlier.
- 2 Leak proof situation required.
- 3 Sensitivity to insulation resistance low.

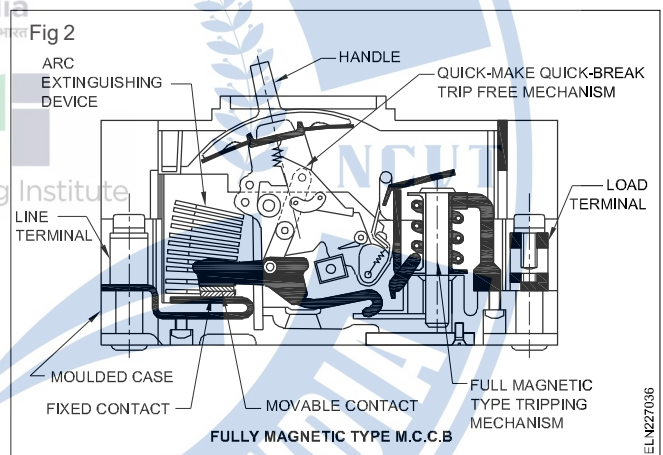

## ELCB - types - working principle - specification

**Objectives :** At the end of this exercise you shall be able to

- explain the working principle, different types and construction of an earth leakage circuit breaker (ELCB)
- explain the technical specifications of ELCB's.

### Introduction

The sensation of electric shock is caused by the flow of electric current through the human body to earth. When a person comes in contact with electrically live objects like water heaters, washing machines electric iron etc., the extent of damages caused by this current depends on its magnitude and duration.

This kind of current is called the leakage current which comes in milli-amperes. These leakage current being very small in magnitude, hence undetected by the fuses/MCBs are the major cause for the fires due to electricity.

The leakage current to earth also results in the wastage of energy and excessive billing for electricity not actually used.

These residual current circuit breakers (RCCB) are popularly called as Earth leakage circuit breakers (ELCB).

Basically ELCBs are of two types namely voltage operated ELCBs and the current operated ELCBs.

### Voltage operated ELCB

This device is used for making and breaking a circuit. It automatically trips or breaks the circuit when the potential difference between the protected metal work of the

installation and the general mass of earth exceeds 24V. This voltage signal will cause the relay to operate (Fig 1).

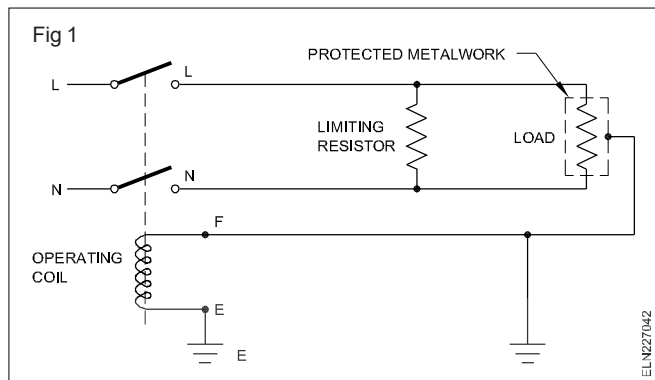

Voltage operated ELCBs are meant to be used where it is not practicable to meet the requirements of IEE wiring regulation by direct earthing or where additional protection is desirable.

### Current operated ELCB

This device is used for making and breaking a circuit and for breaking a circuit automatically when the vector sum of current in all conductors differs from zero by a predetermined amount. Current operated ELCBs are much more reliable in operation, easier to install and maintain.

### Construction of current operated ELCB

It consists of a Torroid ring made of high permeability magnetic material. It has two primary windings each carrying the current flowing through phase and neutral of the installation. The secondary winding is connected to a highly sensitive electro-magnetic trip relay which operates the trip mechanism.

### Working principle

The residual current device (RCD) is a circuit breaker which continuously compares the current in the phase with that in the neutral. The difference between the two is called as the residual current which is flowing to earth.

The purpose of the residual current device is to monitor the residual current and to switch off the circuit if it rises from a preset level (Fig 2&3).

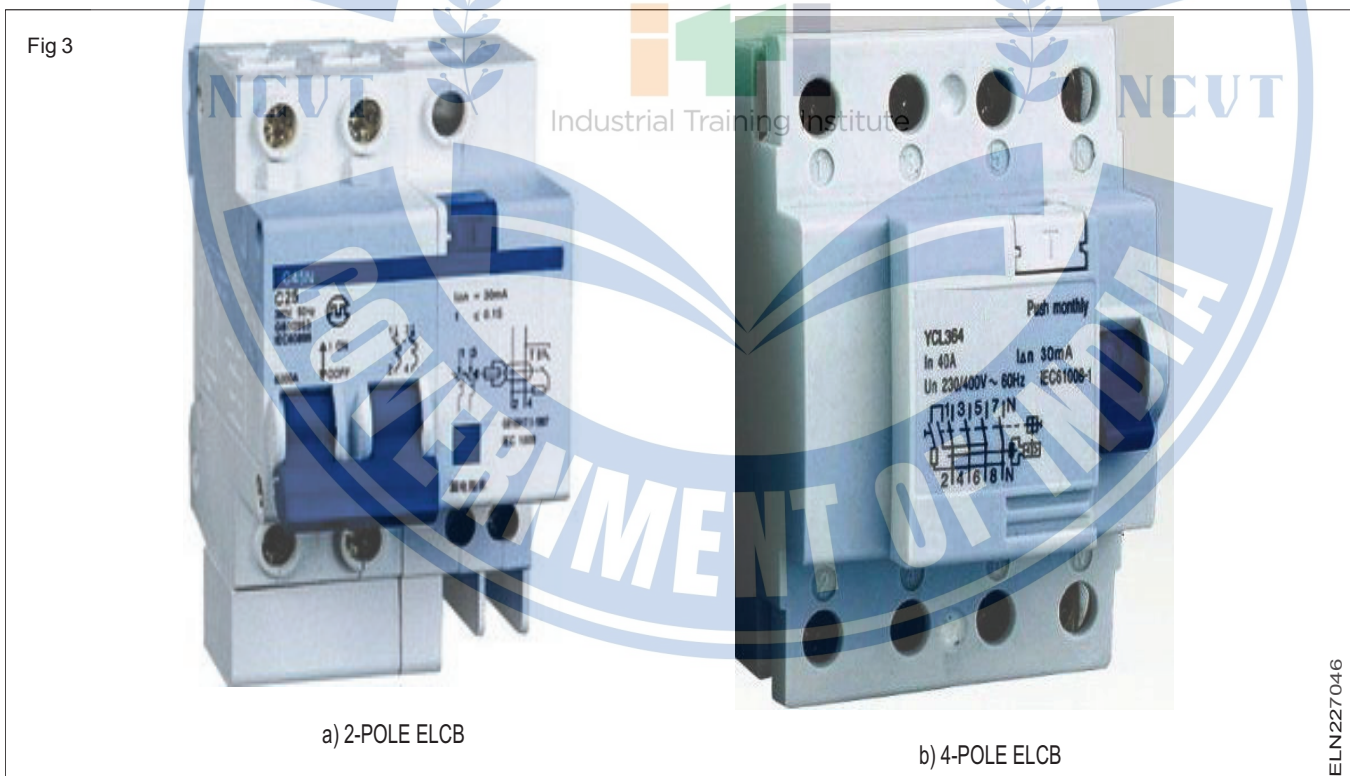
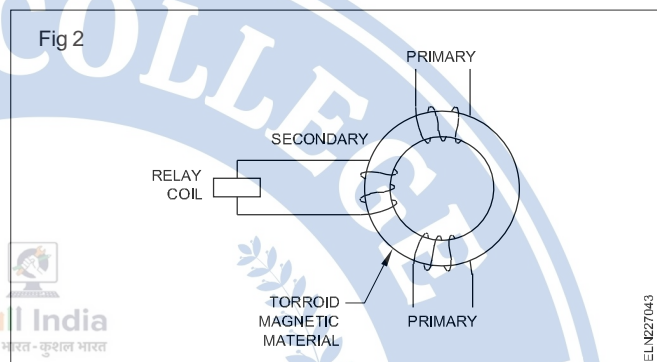

The main contacts are closed against the pressure of a spring which, provides the energy to open them when the device trips. Phase and neutral current pass through identical coils wound in opposing direction on a magnetic circuit, so that each coil will provide equal but opposing numbers of ampere turns when there is no residual current.

The opposing ampere turns will cancel and no magnetic flux will be set up in the magnetic circuit.

In a healthy circuit the sum of the current in phases is equal to the current in the neutral and vector sum of all the current is equal to zero. If there is any insulation fault in the circuit then leakage current flows to earth. This residual current

passes to the circuit through the phase coil but returns through the earth path and avoids the neutral coil, which will therefore carry less current.

So the phase ampere turns exceeds neutral ampere turns and an alternating magnetic flux results in the core. The flux links with the secondary coil wound on the same magnetic circuit inducing an emf into it. The value of this

emf depends on the residual current, so it drives a current to the tripping system which depends on the difference between them and neutral current.

When tripping current reaches a predetermined level the circuit breaker trips and open the main contacts and thus interrupts the circuit.

## Fuses

**Objectives:** At the end of this lesson you shall be able to

- explain the purpose of the fuse in a circuit
- classify the different types of fuses and their uses.

**Purpose of fuses:** A fuse is a safety device used for the purpose of protecting a circuit against excess current. In the event of excessive current, the fuse element melts and opens up the circuit thereby protecting it from damage.

**Symbols:** These are the graphical symbols used to illustrate an electrical fuse in electro-technical diagrams.

- General symbols of a fuse (Fig 1)

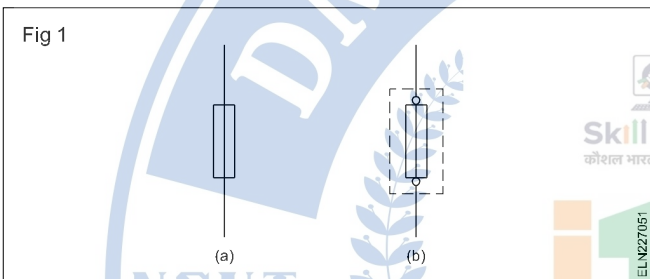

**Placement of fuses:** In electrical installations, the fuses are always connected into the live wires (Fig 2) and never into the neutral N.

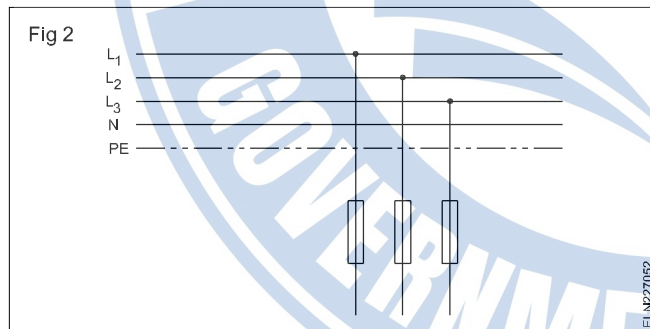

**Types of fuses used in domestic wiring:**

- Re-wirable type (up to 200A)
- Cartridge type (up to 1250A)

**Rewirable type fuse (Fig 3):** The fuse element in this type of fuse consists of a wire which may be replaced when necessary. These fuses are simple in construction and the initial cost as well as the renewal cost is very low.

The fuse elements used in this type are tinned copper wire, lead and tin alloy or aluminium wire (Table 1).

The fuse element will melt after approximately 2 minutes when carrying a current equal to twice the current rating.

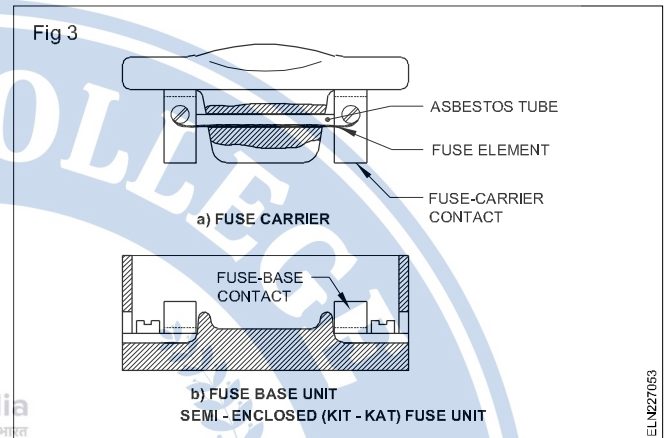

Table 1

Current rating for	Approximate fusing current Amp	Tinned copper wire		Aluminium wire dia. in mm
		S.W.G.	Diameter in mm	
1.5	3	40	.12192	--
2.5	4	39	.13208	-
3.0	5	38	.1524	.195
4.0	6	37	.17272	-
5.0	8	35	.21336	-
5.5	9	34	.23368	-
6.0	10	33	.254	.307
7.0	11	32	.27432	-
8.0	12	31	.29464	-
8.5	13	30	.31496	-
9.5	15	-	---	.400
10.0	16	29	.34544	-
12.0	18	28	.37592	-
13.0	20	-	---	.475
13.5	25	-	---	.560
14.0	28	26	.4572	-
15.0	30	25	.508	.630

### Disadvantages of rewirable type fuse:

- Effected by the fluctuation of the ambient temperature.
- External flash or arc on blowing.
- Poor rupturing capacity (under short-circuit condition).
- Wrong rating possible by human error.

Rewirable-type fuses up to 16A rated current should not be used in locations where short circuit level exceeds 2 KA, (I.S. 2086-963).

**Cartridge fuses:** Cartridge fuses are developed to overcome the disadvantages of the rewirable fuses. As cartridge fuse elements are enclosed in an air tight chamber, deterioration does not take place. Further the rating of a cartridge fuse could be accurately determined from its marking. However, the cost of replacement of cartridge fuses is more than that of rewirable fuses.

- Ferrule-contact cartridge fuses (Fig 4).

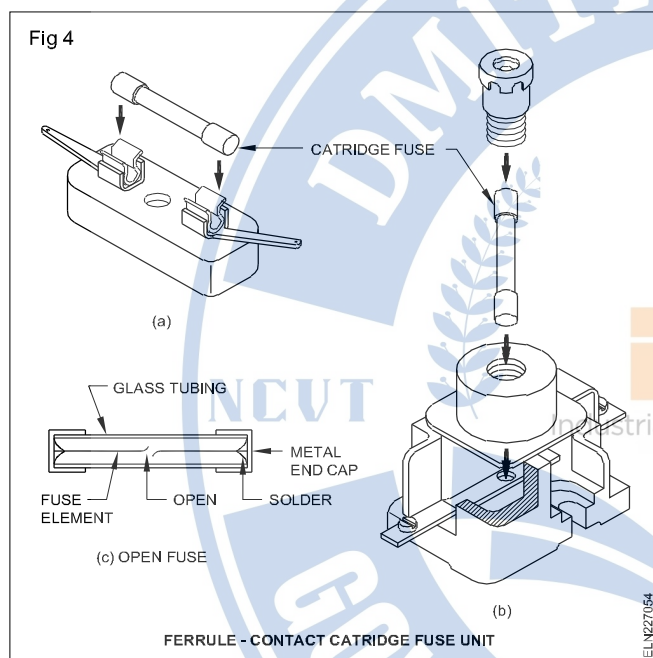

**Ferrule-contact cartridge fuses:** This type, is used for protecting electrical and electronic circuits. These are available in 25, 50, 100, 200, 250, 500 milliamperes, and also in 1,2,5,6,10,16 & 32 amperes capacity.

Normally the current rating is written on one side of the cap, and while replacing, the same capacity fuse should be used. Its body is made of glass and the fuse wire is connected between two metallic caps.

This fuse can be plugged into the fuse socket (Fig 4a) or it can be fitted into a fuse base with a screw, type fuse-holder (Fig 4b).

**High rupturing capacity (HRC) fuses (Fig 5):** They are cylindrical in shape and are made of a ceramic body filled in with a chemically treated filling powder or silica to quench the arcing quickly without any fire hazard.

Normally a silver alloy is used as the fusing element and when it melts due to the excessive current, it combines with the surrounded sand/powder, and forms small globules without making an arc, spark or gas. HRC fuses can open a short-circuited circuit within 0.013 second. It has an indicator to show the fuse has blown.

As HRC fuses are capable of opening circuits having very high faulty currents, these are preferred in high power circuits even though the replacement cost is high.

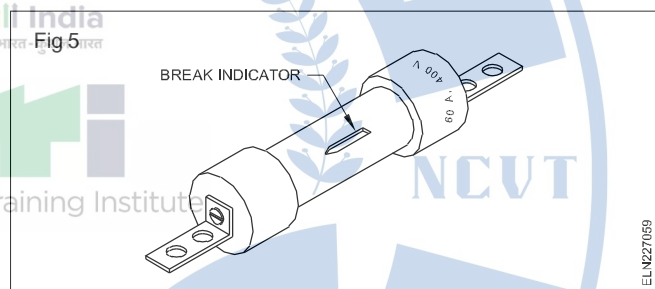

## Relays - types - symbols

**Objectives:** At the end of this lesson you shall be able to

- define a relay and classify the relays
- classify relays according to the operating force and function
- state the causes of the failure of the relay.

**Relay:** A relay is a device which opens or closes an auxiliary circuit under predetermined conditions in the main circuit.

Relays are extensively used in electronics, electrical engineering and many other fields.

There are relays that are sensitive to conditions of voltage, current, temperature, frequency or some combination of these conditions.

Relays are also classified according to their main operating force as stated under.

- Electromagnetic relays

- Thermal relays

**Electromagnetic relay:** A relay switch assembly is a combination of movable and fixed low-resistance contacts that open or close a circuit. The fixed contacts are mounted on springs or brackets, which have some flexibility. The movable contacts are mounted on a spring or a hinged arm that is moved by the electromagnet in the relay (Fig 1).

The other types of relays coming under this group are as follows.

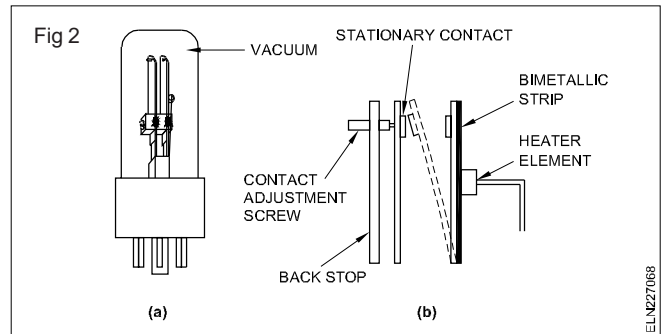
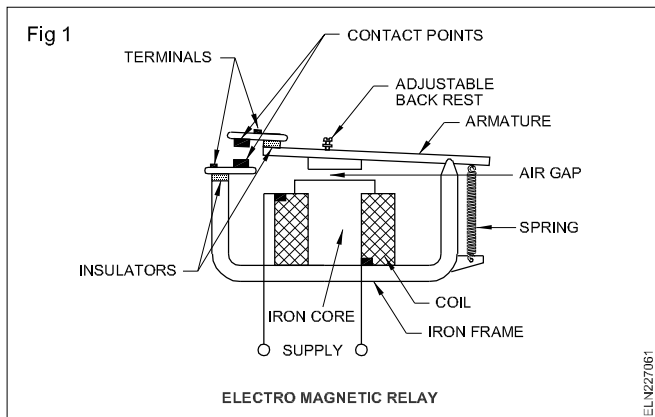

**Causes of relay failures:** Relay failures are usually caused by the gradual deterioration of the parts. This deterioration can be electrical, mechanical or chemical in nature.

The environmental shirks that contribute to physical breakdown include large temperature changes, shock, vibration and voltage or current changes. Therefore, it is important that these factors are taken into consideration to ensure reliable performance of relays.

In general, when a relay fails, look for the following.

- 1 Improper control voltage.
- 2 Dirt, grease or gum on contacts or moving parts.
- 3 Excessive heating of parts: discolouration or charred insulation on coil or base.
- 4 Bending of moving parts.
- 5 Corrosion or deposits on metal parts.
- 6 Excessive wear on moving parts.
- 7 Loose connections.
- 8 Improper spring tension.
- 9 Improper control pressure.
- 10 Improper functioning of the time delay device.

**Current sensing relay:** A current sensing relay functions whenever the current in the coil reaches an upper limit. The difference between the current specified for pick up (must operate) and non-pick up (must not operate) is usually closely controlled. The difference in current may also be closely controlled for drop out (must release) and non-drop out (must not release).

**Under-current relay:** Under-current relay is an alarm or protective relay. It is specifically designed to operate when the current falls below a predetermined value.

**Voltage sensing relay:** A voltage sensing relay is used where a condition of under-voltage or over-voltage may cause a damage to the equipment. For example, these types of relays are used in voltage stabilizers. Either a proportional AC voltage derived from a transformer or a proportional DC derived from a transformer and rectifier used for this purpose.

**Thermal relay:** A thermal relay (Fig 2) is one that operates by changes in temperature. Most of the bimetallic relays where the bimetallic element changes its shape, in response to changes in temperature comes under this group.

It takes time for the heating element to reach the necessary temperature and more time to raise the temperature of the bimetallic element. Therefore, thermal relays are often used as time-delay relays.

## Types domestic wiring

**Objectives:** At the end of this lesson you shall be able to

- state the types wiring used in domestic installations.

### Introduction

The type of wiring to be adopted is dependent on various factors viz. location durability, safety, appearance, cost and consumer's budget etc.

### Types of wiring

The following are the types of internal wiring used in domestic installations.

- Cleat wiring (for temporary wiring only)
- CTS/TRS (batten) wiring
- Metal/PVC conduit wiring, either on surface or concealed in the wall.
- PVC casing & capping wiring

### Cleat wiring

This system uses insulated cables supported in porcelain cleats (Fig 1).

Cleat wiring is recommended only for temporary installations. These cleats are made in pairs having bottom and top halves (Fig 2). Bottom half is grooved to receive the wire and the top half is for cable grip.

Initially the bottom and top cleats are fixed on the wall loosely according to the layout. Then the cable is drawn through the cleat grooves, and it is tensioned by pulling and the cleats are tightened by the screw.

The cleats are of three types, having one, two or three grooves, so as to receive one, two or three wires.

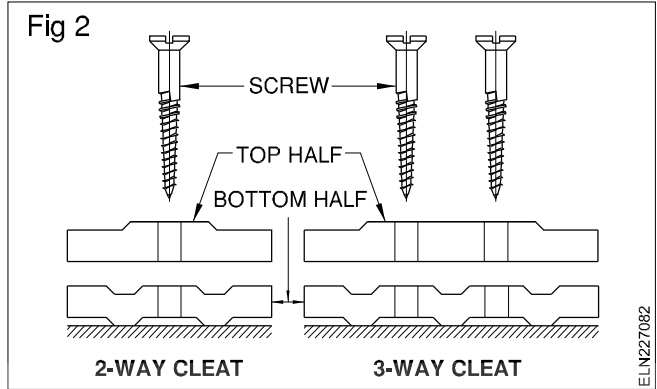
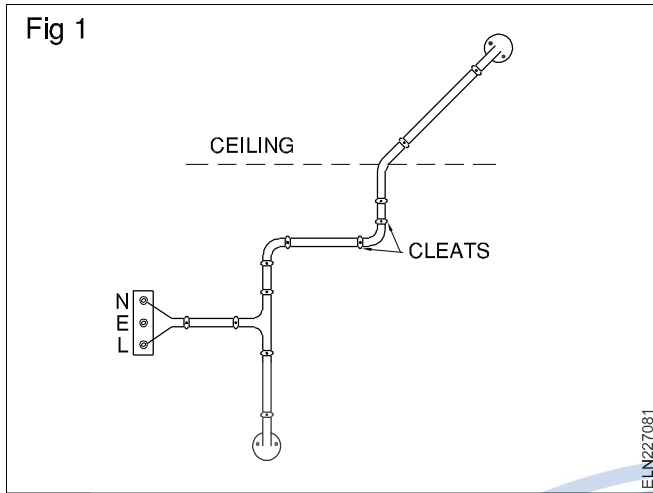

Cleat wiring is one of the cheapest wirings considering the initial cost and labour, and is most suitable for temporary wiring. This wiring can be quickly installed, easily inspected and altered. When not required this wiring could be dismantled without damage to the cables, cleats and accessories. This type of wiring may be done by semi-skilled persons.

## Types of Power wiring

**Objectives:** At the end of this lesson you shall be able to

- explain the types of electrical wiring and their application
- state the advantages and disadvantages of each types.

Many wiring systems are developed to meet the safety requirements, economy of cost, easy maintenance and trouble shooting. A particular system can be chosen according to technical requirements but the system needs to be approved by the local electricity authorities. The following are the fundamental requirements for any wiring system. They are:

- For safety, switches should control the live phase wire. The second terminal of the switch called as half wire should be connected to the appliance or socket through the wire. The neutral can be connected directly to the appliance, socket or lamp.
- For safety, fuses should be placed in the live/phase wire only.
- To supply the rated voltage, parallel connections should be given to all lamps and appliances.

**Types of wiring system:** There are three types of wiring systems used for tapping supply from mains to the different branches. They are as follows.

- 1 Tree system
- 2 Ring main system
- 3 Distribution board system

**Tree system:** In this system, copper or aluminium strips in the form of bus bars are used to connect the main supply to the raising mains (Fig1). This system is suitable for multi-story buildings and the bus bar trunking space is provided in the building at a convenient location and at load centres for the purpose of economy.

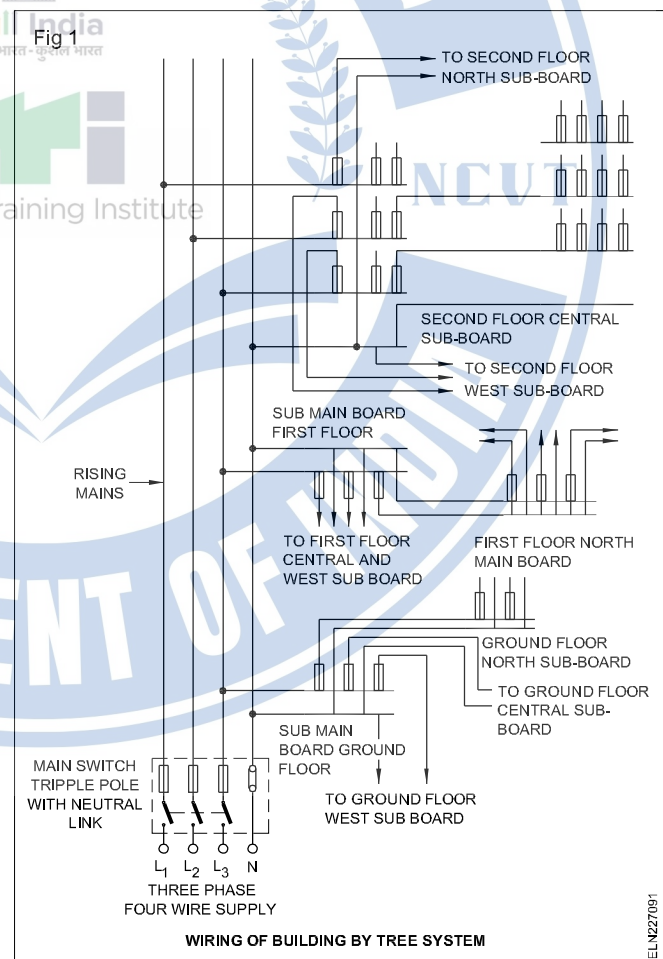

At each floor the running main is connected to the sub-main board through proper cable terminations. If there are more than one flat in each floor the individual main switches for the flat get their supply from the sub-main board through a distribution network which may include an energy meter for each flat.

However the system adopted within the flat will be the distribution board system.

### Advantages

- 1 The length of the cables required for installation will become less. Hence, the cost is less.
- 2 This system is suitable for high rise buildings.

### Disadvantages

- 1 The voltage across the appliances which are at the farthest end of the tree system may be less when compared to the one connected to the nearest end if the bus bars size is not of sufficient size.
- 2 As fuses are located at different places, fault location becomes troublesome.

**Ring main system:** This system consists of two pairs of cables of size 4 or 6sq.mm which run through the rooms and are brought back to the main or sub-board (Fig 2&3).

Tappings are taken for sockets or ceiling roses from the pair of cables through fuses and controlling switches. There may be saving of copper used because the current can be fed from both sides. As this system requires special sockets or plugs with fuses it becomes costly; and hence rarely used in India.

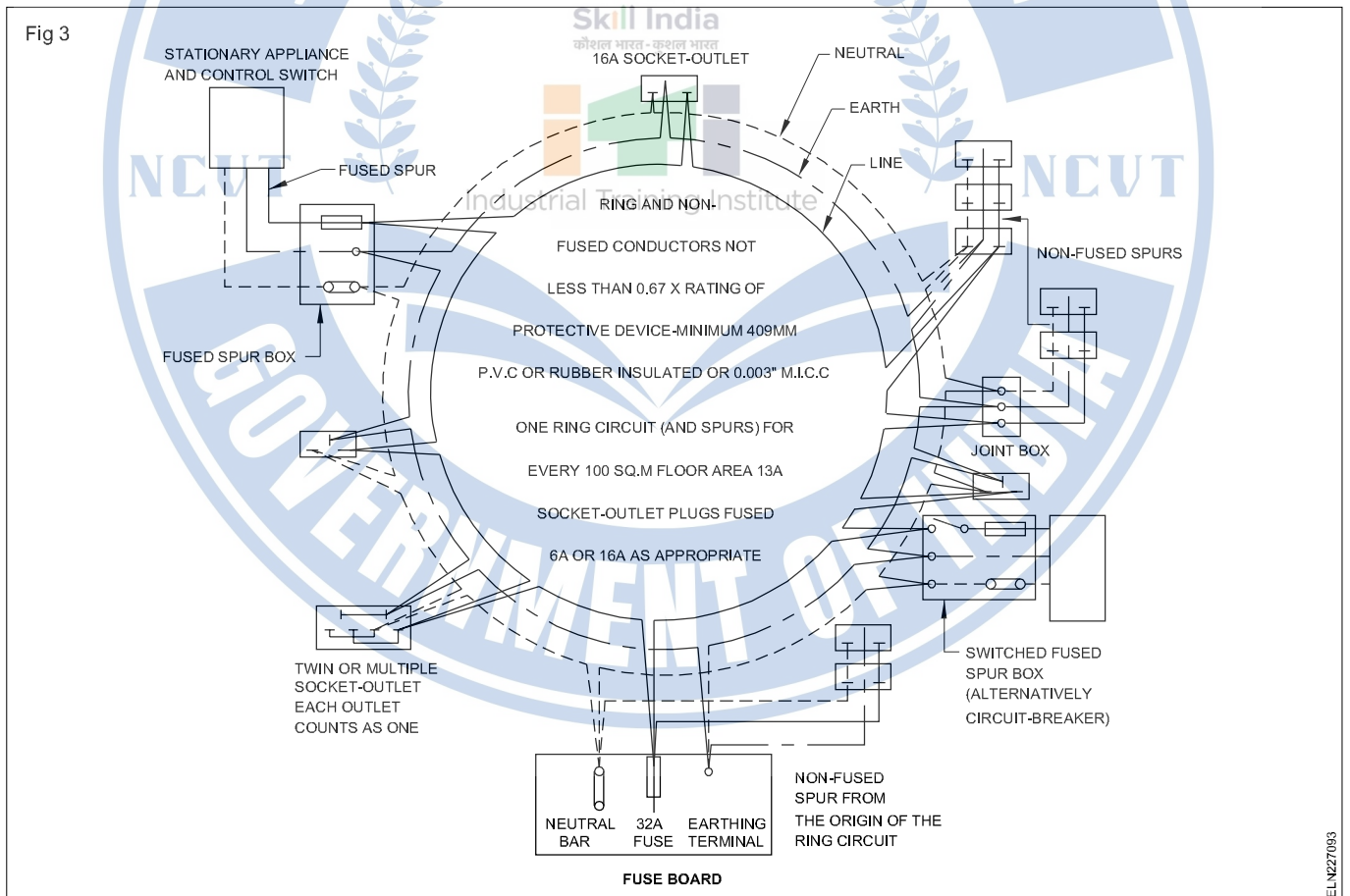
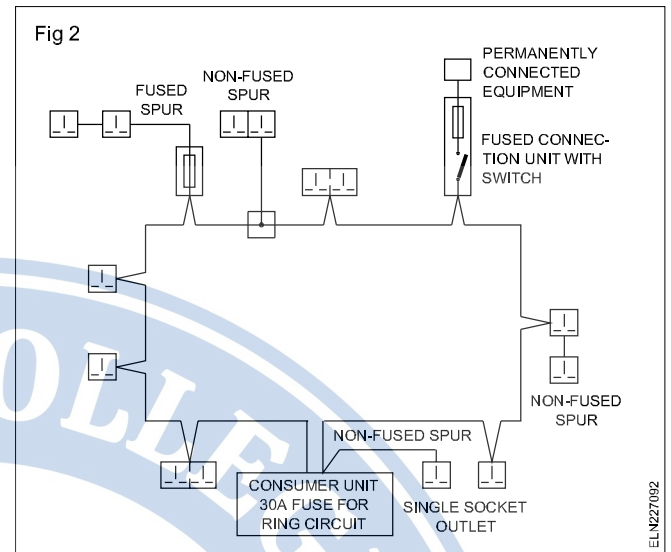

As per IEE regulations one ring circuit has to be there for every 100 sq metres of the floor area or part thereof. The number of power plugs fed from branch lines (spurs) should not exceed two and the total current should not exceed 30

amps. Protection for individual power plug can be provided by having built-in-fuses with the individual power plugs or by having MCB type switch and socket arrangement.

**Distribution board system:** This is the most commonly used system. This system enables the appliances connected to the system to have the same voltage. The main switch is connected to the distribution board through suitable cables. The distribution board has a number of fuses depending upon the number of circuits required in the installation, and the phase and neutral cable of each phase are taken from the distribution board (Fig 4).

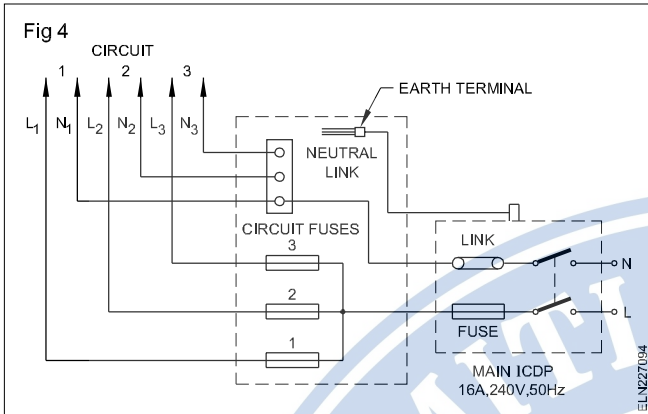

As each circuit can have power up to 800 watt, the phase wire which is taken from the circuit fuse of the distribution board is looped to the other light switches or fan switches of the same circuit by any one of the following ways.

**No joint is allowed in the cable route except in switches, ceiling roses and joint boxes.**

**a Looping out from switch and ceiling rose:** Fig 5 shows the simple looping in method which is commonly employed. The phase wire which is connected to the terminals of the switch is looped out to the next switch and so on, whereas the neutral wires are looped together from ceiling roses (Fig 5). Cable consumed in this system is very high.

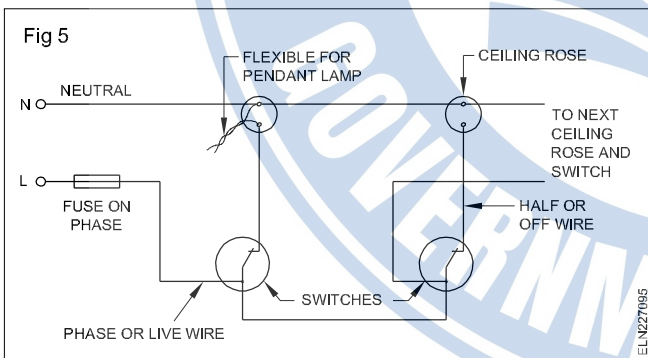

**b Looping out from switch:** This system employs special switches having two terminals and one connector (Fig 6). Both the phase and neutral cables are taken to the switch for looping the cables. As these accessories are not commonly manufactured in India such a system is not used.

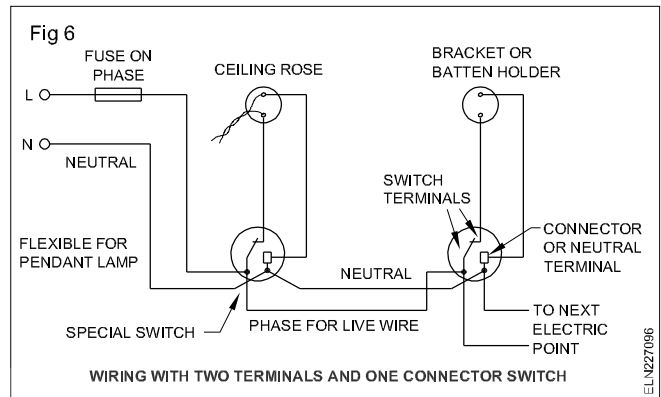

**c Looping out from 3-plate Ceiling roses:** In this type of system, three terminal ceiling roses need to be used. As this system uses less cables when compared to (a), this system is in use in some parts of India. (Fig 7)

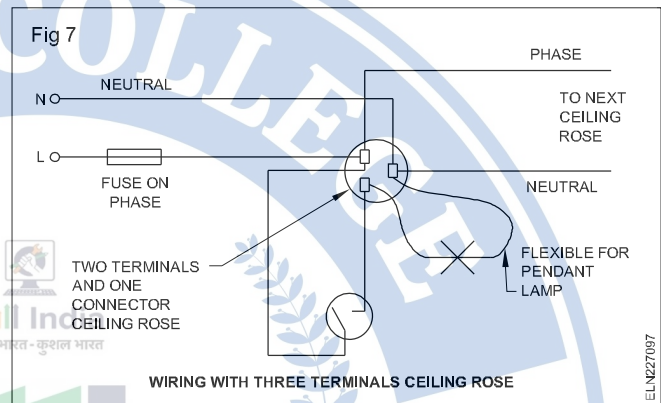

**d Looping out with junction box:** In this system a pair of conductors from the distribution board is brought to the junction box and tapings are taken to switches, two plate ceiling roses as well as other points from the junction box. This method may be economical for lodges where a row of rooms are constructed on either side of a common corridor. (Fig 8)

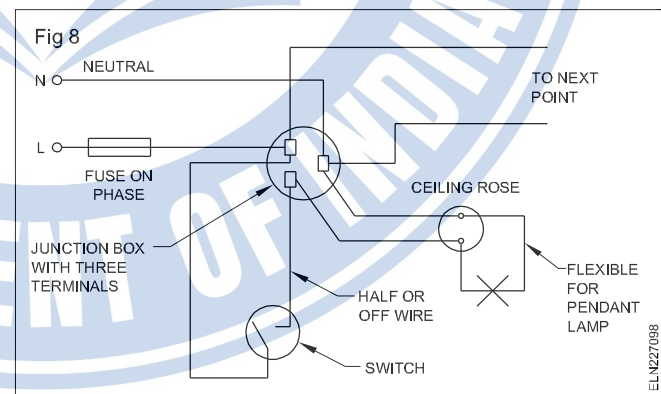

**Principle of laying out of domestic wiring**

**Objectives:** At the end of this lesson you shall be able to

- explain the layout, installation plan, circuit diagram, wiring diagram and state their uses
- state the B.I.S. regulation pertaining to wiring installation.

In electrical wiring work, the electrician is supplied with a layout of wiring installation and an installation plan initially.

On the basis of the layout and installation plan, the electrician should draw the circuit and wiring diagrams before the commencement of work for systematic execution of the work.

The terms used in wiring installation drawings are explained here.

**Layout diagram:** Some customers give their requirements in writing. But a few can give them in the form of a layout diagram to the electrician.

The layout diagram (Fig 1) is a simplified version of the wiring diagram. Its purpose is to inform the reader quickly and exactly, what the circuit is designed for without giving any information on the circuit itself.

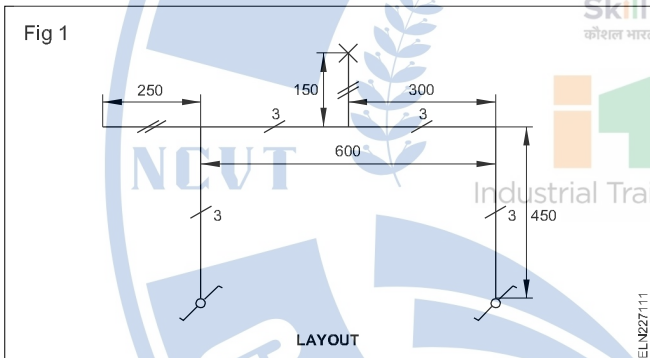

This type of layout diagram is used for preparing architectural diagrams, plans, etc. of a building.

In a layout diagram, it is necessary to indicate with symbols details like whether the wiring is on the surface or concealed, and the run 'up' or 'down', the number of wires in run, dimensions, and accessories with appropriate I.S. symbols.

**Installation plan (Fig 2):** This plan shows the physical position of accessories in an installation, and also gives the final appearance of the installation.

**Circuit diagram (Fig 3):** This shows the schematic connections of the circuit for a specific task in the simplest form, incorporating the graphical symbols.

The purpose of a circuit diagram is to explain the function of the various accessories in the circuit. Fig 3 is an example of a circuit diagram for controlling a lamp from two different places.

**Wiring diagram (Fig 4):** This is the diagram in which the position of the components in the diagram bears a resemblance to their actual physical position.

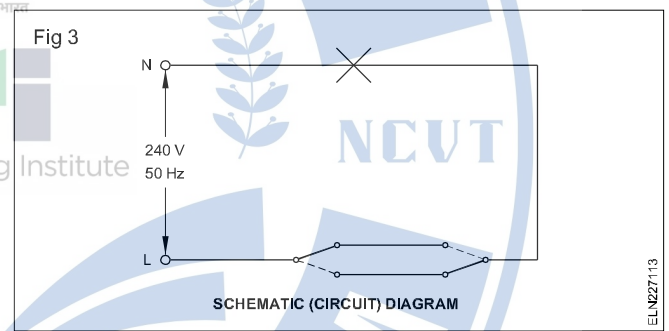
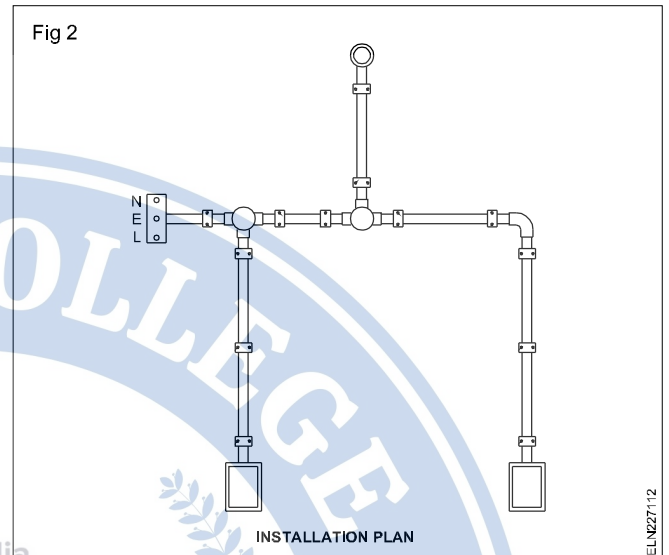
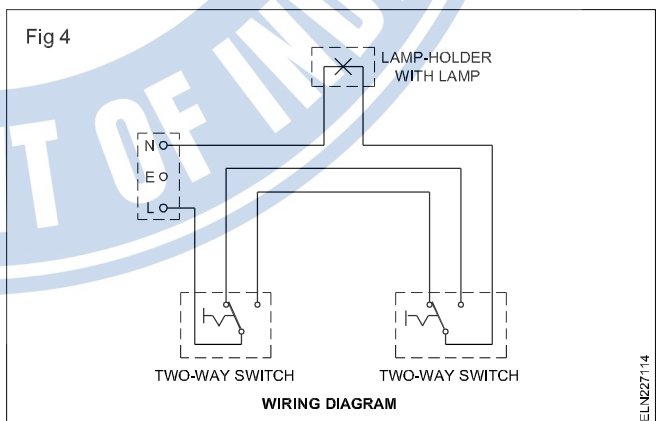

Fig 4 also shows the wiring plan for controlling a lamp from two different places with their actual locations.



For his own good and to facilitate quick location of faults at a later stage, the customer should insist on the electrician giving him a copy of the wiring diagram soon after the completion of wiring.

## **B.I.S. Regulations and the N .E. code pertaining to wiring installations**

The wiring installation shall generally be carried out in conformity with the requirements of the Indian Electricity Act 1910, as updated from time to time and the Indian Electricity Rules 1956, framed thereunder, and also the relevant regulations of the electric supply authority of the concerned area (State Government).

The following are some of the extracts of B.I.S. (Bureau of Indian Standards) regulations pertaining to wiring installations. All the B.I.S. regulations are recommended by the National Electrical Code (NEC).

### **B.I.S. regulations pertaining to wiring installations**

**Wiring:** Any one of the following types of wiring may be used in a residential building.

- Tough rubber-sheathed or PVC-sheathed or batten wiring.
- Metal-sheathed wiring system
- Conduit wiring system:
  - a rigid steel conduit wiring
  - b rigid non-metallic conduit wiring
- Wood casing wiring

### **Permissible load in sub circuit and power circuit**

**Sub-circuits - different types:** The sub-circuits may be divided into the following two groups:

- Light and fan sub-circuit
- Power sub-circuit.

After the main switch, the supply shall be brought to a distribution board. Separate distribution boards shall be used for light and power circuits.

**Light and fan sub-circuits:** Lights and fans may be wired on a common circuit. Each sub-circuit shall have not more than a total of ten points of lights, fans and 6A socket-outlets. The load on each sub-circuit shall be restricted to 800 watts. If a separate circuit is installed for fans, the number of fans in that circuit shall not exceed ten.

**Power sub-circuits:** The load on each power sub-circuit should normally be restricted to 3000 watts. In no case shall there be more than two outlets on each sub-circuit.

If the load on any power sub-circuit exceeds 3000 watts, the wiring for that sub-circuit shall be done in consultation with the supply authority.

**Lighting :** A switch shall be provided adjacent to the normal entrance to any area for controlling the general lighting in that area. The switches should be fixed on a usable wall space and should not be obstructed by a door or window in its fully open position. They may be installed at any height up to 1.3m above the floor level.

The light fittings in kitchens should be so placed that all working surfaces are well illuminated and no shadow falls on them when in normal use.

For bathrooms, it is recommended to use ceiling lighting with the switch located outside the bathroom.

It is recommended that lighting facilities be provided for lighting of all steps, walkways, driveways, porch, carport, terrace, etc, with switches for each provided inside the house at a convenient place. If the switches are installed outdoors, they should be weatherproof.

Waterproof lighting fittings should be used for outdoor lighting.

**Socket-outlets:** All plugs and socket-outlets shall be of 3-pin type, the appropriate pin of the socket being connected permanently to the earthing system.

An adequate number of socket-outlets shall be placed suitably in all rooms so as to avoid the use of long lengths of flexible cords.

Only 3-pin, 6A socket-outlets shall be used in all light and fan sub-circuits. 3 pin, 16A socket-outlets shall be controlled by individual switches which shall be located immediately adjacent to it. For 6A socket-outlets, if installed at a height of 130 cm above the floor level, in situations where a socket-outlet is accessible to children, it is recommended to use shuttered or interlocked socket-outlets.

Dining rooms, bedrooms, living rooms, and study rooms, if required, shall each be provided with at least one 3-pin, 16A socket outlet.

No socket-outlet shall be provided in the bathroom at a height less than 130 cm.

**Fans:** Ceiling fans shall be wired to ceiling roses or to special connector boxes. All ceiling fans shall be provided with a switch besides its regulator.

Fans shall be suspended from hooks or shackles with insulators between the hooks or shackles and also with insulators between the hooks and suspension rods.

Unless otherwise specified, all ceiling fans shall be hung not less than 2.75 m above the floor.

**Flexible cords:** Flexible cords shall be used only for the following purposes.

- For pendants
- For wiring of fixtures
- For connection of transportable and hand-held appliances

### **Mounting levels of the accessories and cables as recommended in B.I.S. and N.E.C.**

Height of main and branch distribution boards should be not more than 2m from the floor level. A front clearance of 1 m should also be provided.

All the lighting fittings shall be at a height of not less than 2.25 m from the floor.

A switch shall be installed at any height 1.3 m above the floor level.

Socket-outlets shall be installed either 0.25 or 1.3 m above the floor as desired.

The clearance between the bottom point of the ceiling fan and the floor shall be not less than 2.4 m. The minimum clearance between the ceiling and the plane of the blades of the fan shall not be less than 300 mm.

The cables shall be run at any desired height from the ground level, and while passing through the floors in the

case of wood casing and capping and T.R.S. wiring, it shall be carried in heavy gauge conduit 1.5 m above floor level.

### References

I.S. 732-1963

I.S. 4648-1968

N.E. Code

## Selection of the type and size of cable for a given wiring installation and voltage drop concept

**Objectives:** At the end of this lesson you will be able to

- state the factors to be considered for selecting the cable for a circuit
- apply the factors and select the cable.

In order to determine the type and size of the cable for a given circuit, the following points should be taken into account.

- Suitability of the type of cable for the location of the circuit and the type of wiring.
- Size of the cable depending upon the current carrying capacity of the cable.
- Size of the cable depending upon the length of the wiring and permissible voltage drop in the cable.
- Minimum size of the cable based on the economy.

### Location of the circuit and the type of wiring decide the type of cable.

It is necessary to consider whether the installation is for industry or domestic use and whether the atmosphere is damp or corrosive. Accordingly the type of cable has to be chosen.

Further the type of wiring determines the type of cable suitable for the installations.

### The current carrying capacity of the cable decides the size of the cable.

In this, the first step is to find out the current expected to flow in the circuit when the total connected load is fully switched on. This current is the maximum current that would flow through the circuit in case all the loads are working at the same time. But this is not the case in actual situations.

### Diversity factor

In the case of lighting installation all the lamps in a domestic installation may not be switched 'on' at the same time. Hence, it is assumed only two thirds of the lights (say 66%) only will be 'on' at a given time. This introduces a factor called 'diversity factor'.

When the connected load is multiplied by the diversity factor you get a load value which can be said as normal working load. Use of this diversity factor enables the technician to use a lesser size cable than the one calculated, based on the connected load.

Based on the working load the current in each circuit is to be calculated and the size of the cable suitable to carry the current has to be chosen.

### Voltage drop in the cable

In any current carrying conductor, voltage drop takes place due to its internal resistance. This voltage drop in a premises as per BIS 732 should not be more than 3 percent of the standard supply voltage when measured between the consumer supply point and any point of the installation when the conductors are carrying the maximum current under the normal conditions of service.

Tables 3 and 4 for aluminium cable and 5 for copper cable give the relation between voltage drop and length of the cable run for various cables. In case the voltage drop found in the cable exceeds the stipulated limit of 3% voltage drop, the technician has to choose the next bigger sized cable to maintain the voltage drop within limits.

If the cable size is increased to avoid voltage drop in the circuit, the rating of the cable shall be the current which the circuit is designed to carry. In each circuit or sub-circuit the fuse shall be selected to match the load or the cable rating whichever is minimum, to ensure the desired protection (BIS 732).

### Declared voltage of supply to consumer

On the other hand according to IE Rule No.54, the voltage at the point of commencement of supply at the consumer should not vary from the declared voltage by more than 5 percent in the case of low or medium voltage or by more than 12 percent in the case of high or extra high voltage (Fig 1).

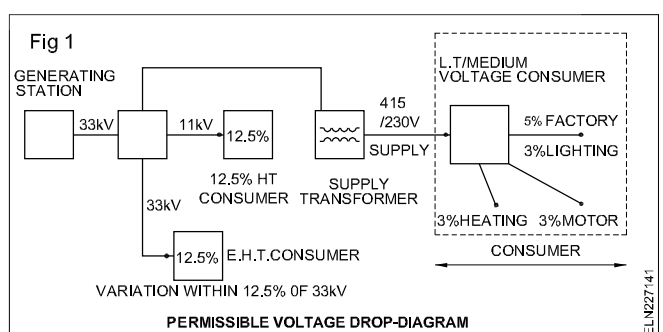

At this stage it is better to remember that when current flows through a conductor, the resistance offered by the conductor produces heat. The increase in heat is proportional to the cable resistance which in turn depends upon the cross-sectional area of the cable. Since overheating damages the insulation, the conductor size must be adequate to prevent this from occurring.

While choosing the cable size, voltage drop is a more severe limitation than any other criterion. Hence, it is advisable to select the cable size only after ascertaining the permissible voltage drop. Excessive voltage drop impairs the performance of heating appliances, lights and the electric motors.

### Calculation of voltage drop

#### In DC and single phase AC two-wire circuits

$$\text{Voltage drop} = \text{Current} \times \text{Total resistance of cables} \\ = 2 IR$$

where I is the current and R is the resistance of one conductor only

Wherever voltage drop is given as 1 volt drop per metre run of cable, we have to assume that both (lead and return) cables are taken into account and the cable carries its rated current. In such cases the voltage drop for X metre length of cable for a current of Y amps is calculated as given.

$$\left\{ \text{Voltage drop} \right\} = \frac{\left\{ \text{Length of the cable} \right\} \times \left\{ \text{Actual current of the load} \right\}}{\left\{ \text{Metre length of the cable per one volt drop} \right\} \times \left\{ \text{Rated current of the cable} \right\}} \\ = \frac{XY}{\left\{ \text{Metre length of the cable per one volt drop} \right\} \times \left\{ \text{Rated current of the cable} \right\}}$$

#### 3-phase circuits

$$\text{Voltage drop} = 1.73 \times I R = \sqrt{3} IR$$

where I is the line current R is the resistance of one core only.

The above points could be explained through the following set of examples.

#### Example 1

A guest house installation has the following loads connected to the three phase 415 V supply with neutral. Select a proper size of cable for this installation.

- 1 Lighting - 3 circuits of tungsten lighting total 2860 watts
- 2 Power from 3 x 30A ring circuits to 16A socket outlets for
  - a 1 x 7 KW Water heater (Instant)

- b 2 x 3 KW Immersion heater (Thermostatically controlled)
- c Cooking appliances: 1 x 3 KW cooker  
1 x 10.7 KW cooker

Current demand in amperes in each of the circuit is calculated by referring the Table 1. Calculate current taking account into the diversity factor.

Assuming the declared voltage as 240 volts and the length of the longest run in a circuit as 50 metres

Permissible voltage drop at the rate of 3%

$$= \frac{3 \times 240}{100} = 7.2 \text{ Volts}$$

**If the size of the conductor selected is 35.0 sq.mm which can carry 69 amps, the voltage drop at 69 amperes rating will be 1 volt for every 7.2 metres cable run.**

For 50 metres cable run the voltage drop at 69 amps current rating = 50 / 7.2 volts.

Voltage drop for 65 amps

$$= \frac{50 \times 65}{7.2 \times 69} = 6.54 \text{ Volts}$$

As the actual voltage drop in the circuit, that is 6.54 volts, is well within the permissible value, of 7.2 volts, the cable selected is suitable for the installation.

**Table 1**

Sl. No	Demand description	Current Demand (Ampere)	Diversity Factor (Table 2)	Current allowing for Diversity (Ampere)
1	Lighting	11.9	75%	9.00
2	Power i	30	100%	30
	ii	30	80%	24
	iii	30	60%	18
				72.00
3	Water heaters (inst)	29.2	100%	29.2
4	Water heaters (thermo)	25.00	100%	25.00
5	Cooker i	12.5	80%	10.00
	ii	44.5	100%	44.5
<b>Total current = 213.1</b>				<b>189.7</b>
Total current demand (allowing diversity) = 189.7 amps Load spread over 3 phases = 189.7/3 = 63.23 amps, say 65 amps per phase.				

# Metal conduit pipe - methods of cutting, threading and bending

**Objectives:** At the end of this lesson you shall be able to

- state the methods of cutting a metal conduit pipe
- state the purpose and process of threading and list out the precautions of conduit pipes
- list the different accessories used in conduit installation
- state the purpose and methods of bending the conduit pipes and list out the precautions.

**Cutting:** Rigid and intermediate conduits may be cut with a hacksaw (Fig 1) or a pipe cutter (Fig 2). With either method, the conduit must be locked in a pipe vice before making the cut.

After cutting (Figs 1 and 2) the inside edge of the conduit must be smoothed with a half round file (Fig 3) or a pipe reamer mounted in a brace.

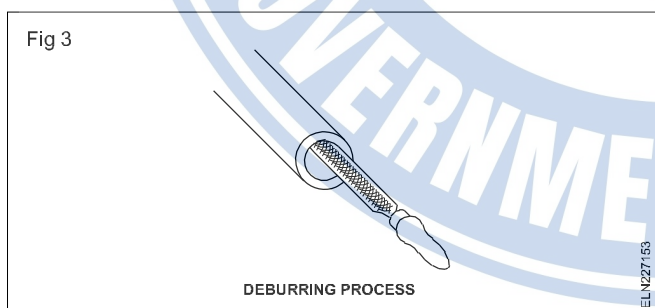
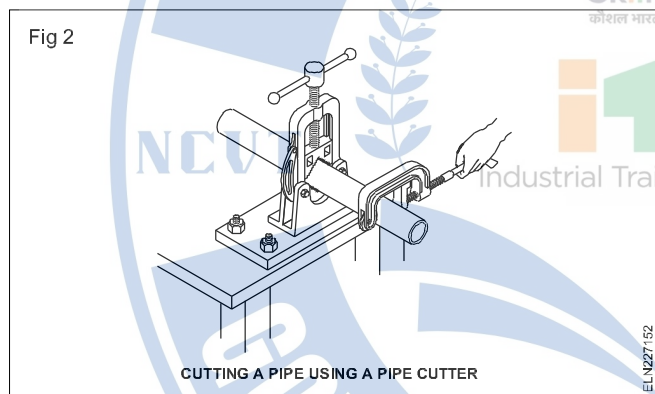
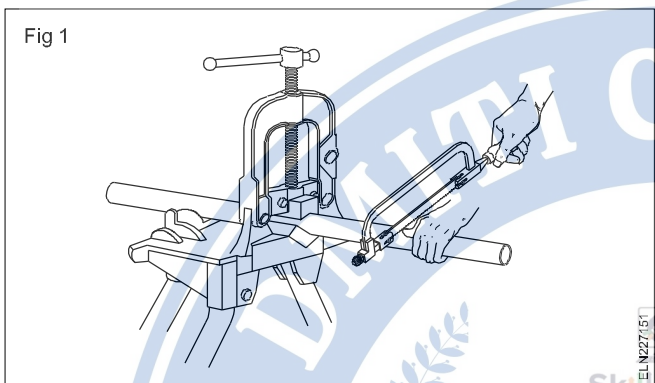

**Threading:** Conduit is threaded by using dies and a die stock. Apply cutting oil to the end of the conduit before starting to cut threads. Cutting the threads longer than necessary will leave the exposed threads subject to corrosion.

Do not use any lubricant which is an electrical insulator, as this may increase the resistance of the conduit assembly and affect its use as the circuit protective earthing conductor.

## Precautions to be observed while threading conduit pipes

- 1 Chamfer the end of the conduit to be threaded.
- 2 Apply a lubricant frequently while threading the conduit pipe. It helps the die to cut more easily and the die to stay sharp.
- 3 Reverse turnings of the die stock are necessary to break off cut chips and to clear the cutting edges of the die.
- 4 Use only a brush to remove the metal burrs from the die. Do not use your hand.

**Conduit fittings like elbows, bends and Tees:** All these fittings are available in two categories.

- Normal
- Inspection type

They are made from cast iron.

Elbows are suitable for short bends whereas bends are suitable for long bends. In general where a conduit runs between the wall and the ceiling, elbows are used. (Fig 4a, b & d)

Tees are used in switch-drops and diversions. Various types of these accessories (Fig 4c).

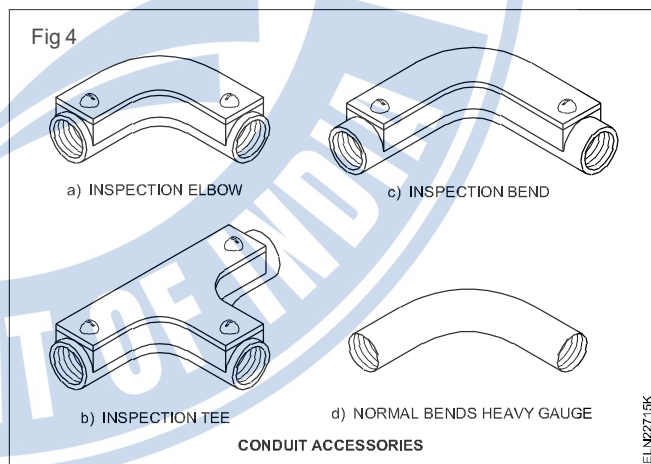

Conduit saddles are used to fasten the conduit on the surface of the walls. These saddles could be used along with any one of the following bases. They are:

- spacers made from sheet metal
- distance piece made from wood or PVC
- hospital piece made from wood or PVC.

Various types of these base fittings along with the saddles are shown in Fig 5.

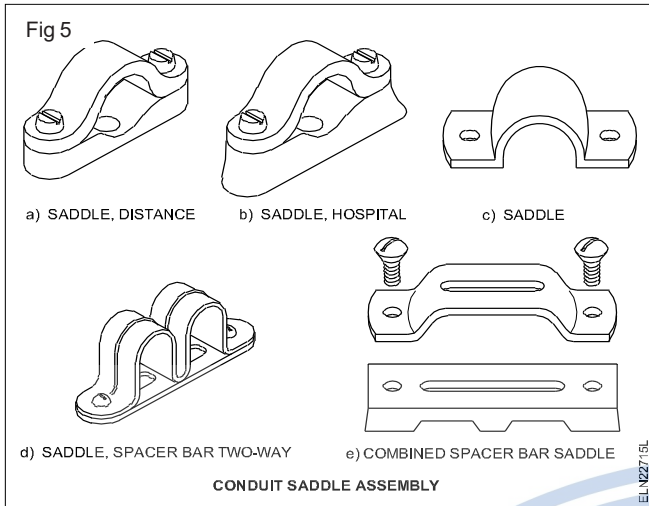

**Metal conduit boxes:** Termination of rigid conduits is done at metal conduit boxes of either cast iron or sheet metal. Various shapes and sizes of boxes are commercially available in the market. Junction boxes of round, square, rectangular and hexagonal shapes are manufactured for one-way, 2-way, 3-way and 4-way outlets.

These outlets may be straight, angular or tangential as required for the situation. When ordering, the specification should contain the material with which the box is to be made, the size of the conduit to be fitted, the number of ways, shape and the position of outlets. (Fig 6)

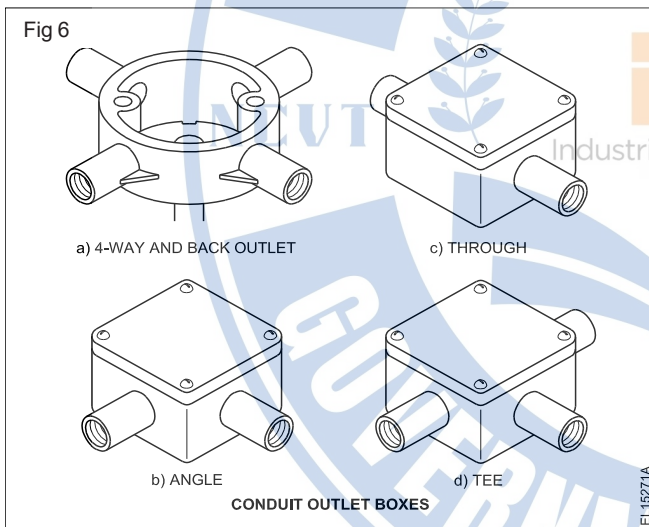

**Conduit pipe bending:** It is often necessary to set or bend the conduit to enable it to pass over an obstruction (Fig 7) or to turn a corner which is less or more than 90° (Fig 8). The bending may be a little offset to the line of conduit installation. This can be manipulated by proper bending as required.

The bending may be done by using a simple bending block or by a hickey or with the help of a bending machine. Further, in concealed conduit wiring, the B.I.S. recommends bending of conduit pipes in preference to the use of bends and elbows.

**Using bending block for bending conduit:** The bending block (Fig 9) is made preferably with teak wood or strong country wood, and should have holes suitable for the conduit to be bent. Edges are chamfered to avoid kinks in

the bent portion of the conduit. Light gauge conduits need to be filled with sand and heated before bending to have smooth bends.

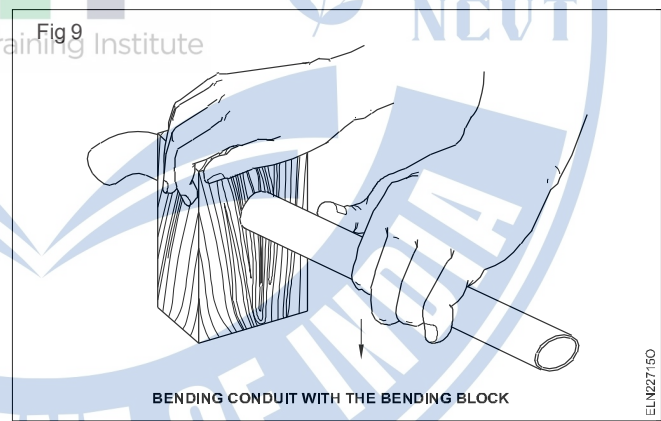
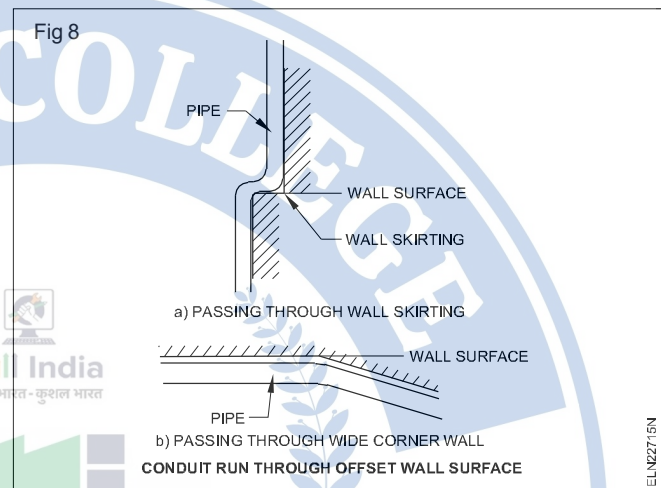
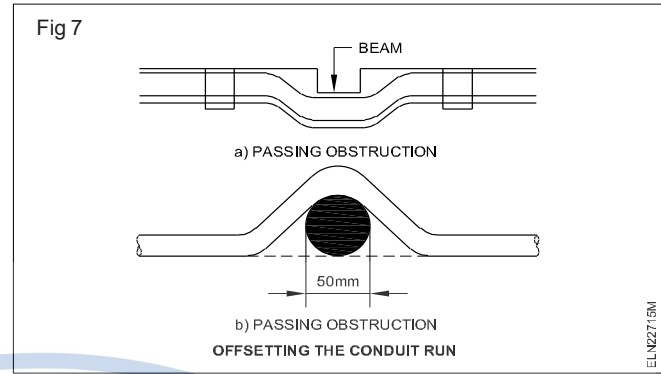

**Using hickey for bending conduits:** A hickey is a special bending tool (Fig 10) and is made of forged steel or alloy steel. A particular size of pipe requires that size of hickey. Bending of pipes could be performed cold or hot by using a hickey.

**Using bending machine for bending conduit:** Various types of bending machines are available in the market. They can either be operated by hand (Fig 11) or by hydraulic pressure. For each size of conduit, the guide and collet need to be changed.

#### Precautions to be observed while bending

- The pipe used should be mechanically strong to withstand the pressure while bending.

Fig 10

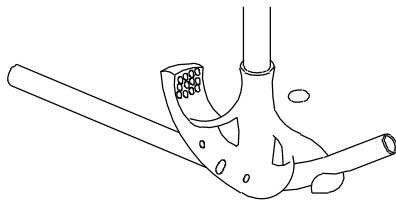

BENDING CONDUIT WITH THE HICKEY

ELN22715P

Fig 11

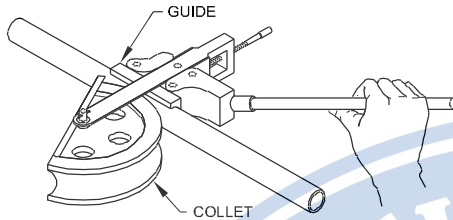

BENDING CONDUIT WITH THE BENDING MACHINE

ELN22715Q

- Poorly seam-welded pipes are not suitable for bending as they may split while bending.
- One of the easy methods of bending is to draw the bending curve on the floor and bend the pipe accordingly.
- When a wooden block is used for bending, chamfer both sides of the hole opening in the block.
- Ensure that the conduit does not twist while bending.
- Use a proper size of hickey according to the dia. of the pipe to be bent.
- While doing manual hot bending do not use wet sand as the steam generated during heating may cause an explosion.

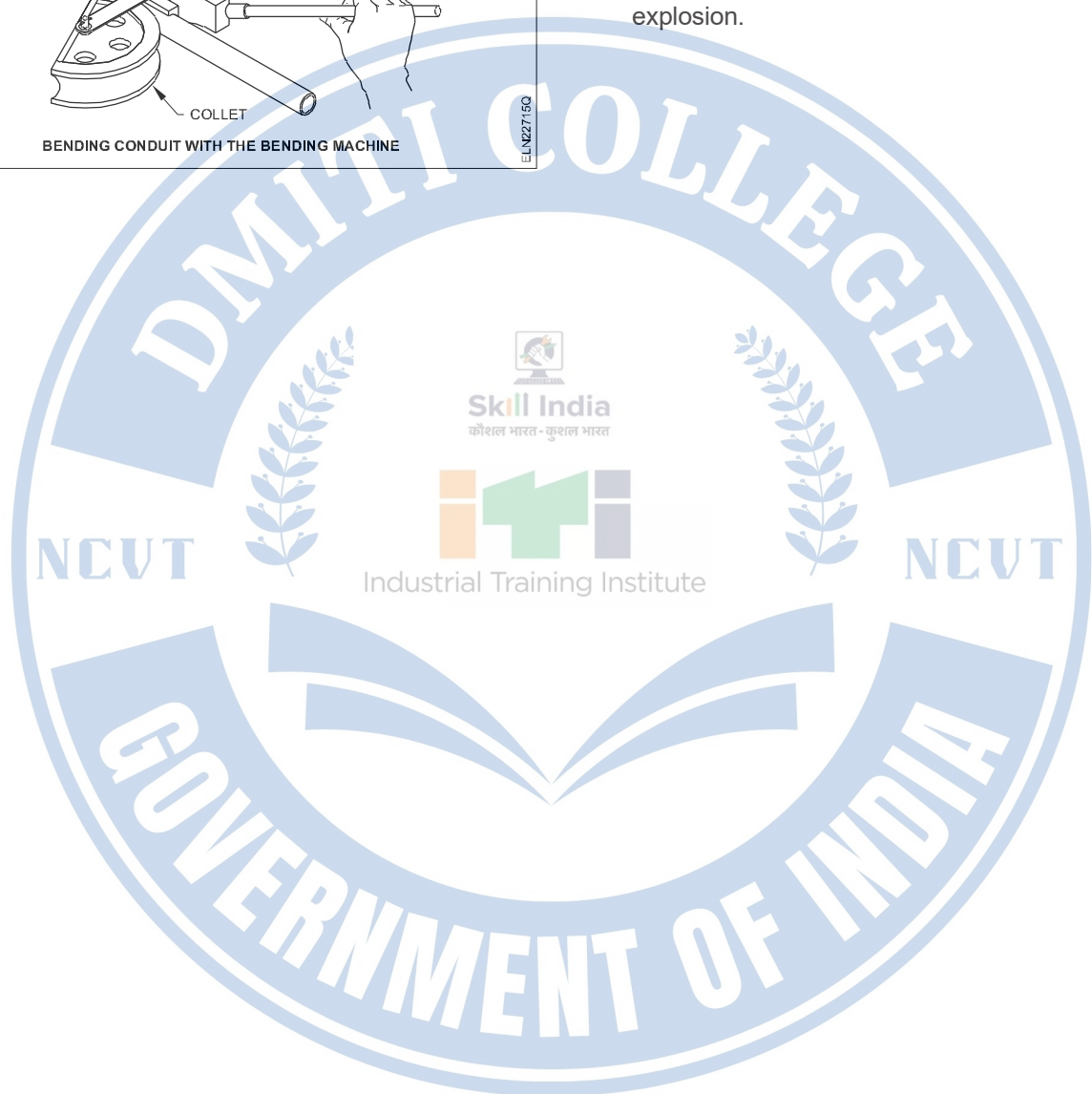

**Test board, Extension board and colour code of cables**

**Objectives:** At the end of this lesson you shall be able to

- explain the method of using a test board
- state the general colour codes used in cables.

**Test board:** A test board is an electric switch board, used for conducting the following tests.

- **Continuity test** (Load connected in series with a lamp)

**Example:** Testing of fan winding, condition of choke and tube light starter etc.

- **Direct test**

**Example :** Testing electrical appliances of 1000 watts or lower rating for proper functioning.

Fig 1 source the schematic diagram of a test board with all the outlets and controls. Sockets P<sub>1</sub> and P<sub>2</sub> provide direct, single-phase supply whereas socket P<sub>3</sub> and terminal block T provide a single-phase supply in series with the lamp L<sub>3</sub>.

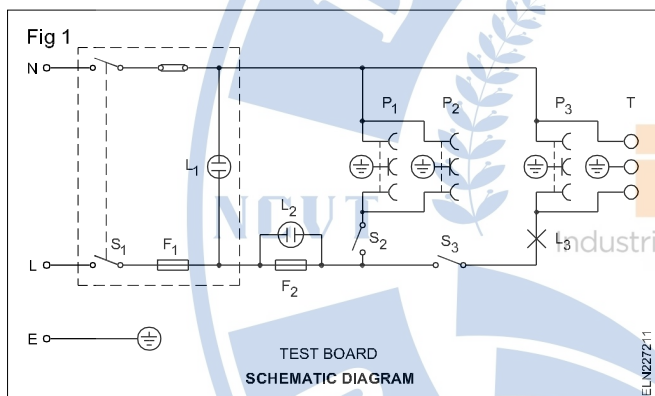

**Continuity test:** While performing a continuity test, the appliance to be tested is connected to the socket P<sub>3</sub> or to the terminal T which are in series with the lamp L<sub>3</sub> and are controlled by switch S<sub>3</sub>. Normally this test is conducted by the electrician to ascertain whether the appliance is open-circuited or short-circuited. A low wattage, appliance when connected, will make the lamp L<sub>3</sub> to burn dim, and a high wattage appliance will make the lamp to burn bright.

According to the brightness of the lamp, the behaviour of the appliance, as well as the wattage of the appliance and the lamp and the condition of the appliance could be judged. 'No light' indicates either open circuit or high resistance in the appliance. In the same way, a choke coil and a starter of a tube light can be checked. (The flickering of the lamp L<sub>3</sub> with the starter indicates that the starter is good.)

Thus the testing board also works as a continuity tester.

**Direct testing:** By connecting the appliance direct to the socket P<sub>1</sub> or P<sub>2</sub>, the performance of the appliance can be verified after repair.

**Fuses:** If the indicator lamp L<sub>1</sub> does not burn, it indicates no supply. On the other hand, in normal conditions, the indicator lamp L<sub>2</sub> will not burn, and it burns only when the fuse F<sub>2</sub> is open.

Thus the test board is a cheap and handy test set which is easy to use by an electrician to carry out his routine checks in the course of his work.

**Colour identification of cables:** The colour of the cables indicates their function. Table 1 gives the colour code and the alpha-numeric notation as recommended by N.E.Code.

The rules apply for marking conductors in equipment/ apparatus/installation.

**Table 1**

**Alpha-numeric notation and colours**

Designation of		Identification by	
		alpha	colour
Supply AC system	Phase 1	L1	Red
	Phase 2	L2	Yellow
	Phase 3	L3	Blue
	Neutral	N	Black
Apparatus AC system	Phase 1	U	Red
	Phase 2	V	Yellow
	Phase 3	W	Blue
	Neutral	N	Black
Supply DC system	Positive	L+	Red
	Negative	L-	Blue
	Mid-wire	M	Black
Supply AC system (Single phase)	Phase	L	Red
	Neutral	N	Black
Protective Earth conductor		PE	Green and yellow
Earth		E	Colour of the bare conductor.

**Extension board (Fig 2)**

Extension boards are used to operate portable electrical appliances/ machines. It is also used where more number of sockets are required at a time.

Extension boards are available in different shapes with PVC (or) plastic boxes provided with 2 core (or) 3 core cables and moulded plugs. Extension boards are available in 6A and 16A ratings.

Fig 2



## Conduit wiring - types of conduits - non-metallic conduits (PVC)

**Objectives:** At the end of this lesson you shall be able to

- distinguish between the different types of conduits used in wiring
- state the different types of accessories used in non-metallic conduits wiring.

In general, conduit is defined as a tube or channel, which is the most commonly used in electrical installations. When cables are drawn through the conduit and terminated at the outlet or switch points, the system of wiring is called conduit wiring.

### Types of conduits

There are four types of conduits used for wiring.

- Rigid steel conduits
- Rigid non-metallic conduits
- Flexible conduits
- Flexible non-metallic conduits.

### Non-metallic conduits

These are made of fibres, asbestos, polyvinyl chloride (PVC), high density polyethylene (HDP) or poly vinyl (PV). Of the above, PVC conduits are popular owing to their high resistance to moisture and chemical atmosphere, high dielectric strength, low weight and low cost. These conduits may be buried in lime, concrete or plaster without harmful effects.

However, light gauge (lower than 1.5 mm wall thickness) PVC pipes are not as strong as metal conduits against mechanical impact. Special PVC pipes which are heavy gauge and high impact resistance are available in the market which can withstand heavy mechanical impact as the thickness of the pipe is more than 2 mm.

There are some PVC heavy gauge conduits having special base material made to withstand temperatures up to 85°C. These PVC conduits are available in 3 m length.

### Variation in conduit wiring systems

There are two types of conduit wiring systems as stated below, for either metallic or non-metallic types.

- Surface conduit wiring system done on wall surfaces.
- Concealed (recessed) conduit wiring system done inside the concrete, plaster or wall.

### Selection of the type of conduit

Metallic or PVC conduits are equally popular in electrical installations. Selection of the type of conduit depends upon the following criteria.

- Type of location, outdoor or indoor
- Type of atmosphere, dry or damp or explosive or corrosive
- Expected working temperature
- Exposure to physical damage due to mechanical impact
- Allowable weight of conduit runs
- Estimated cost.

### Special precautions with non-metallic conduits

- 1 If the conduits are liable to mechanical damages they should be adequately protected.
- 2 Non-metallic conduits shall not be used for the following applications.
- 3 In concealed/inaccessible places of combustible construction where the ambient temperature exceeds 60°C.
- 4 In places where the ambient temperature is less than 5°C.

- 5 For suspension of fluorescent fittings and other fixtures
- 6 In areas exposed to sunlight.

## PVC fittings and accessories

### Couplers (Fig 1)

Normally push type couplers are used and the conduit shall be pushed right through to the interior of the fittings. Inspection type couplers are used in straight conduit runs to assist in the inspection of the cables.

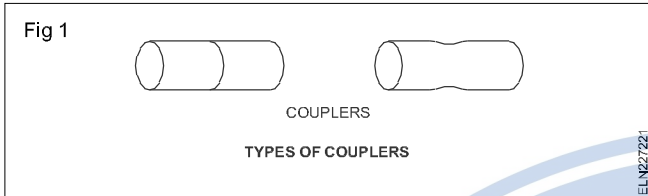

### Elbow (Fig 2)

The axis of any elbow shall be a quadrant of a circle plus a straight portion of each end. Elbows are used at sharp ends of nearby walls or roof and wall.

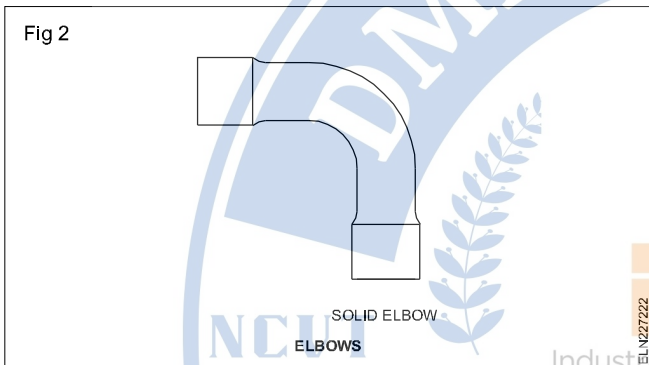

### Bends (Fig 3)

A bend gives a diversion of 90°C in the turn of a conduit, and a normal bend shall be a large sweep. Inspection type bends are used to assist in the inspection at the corners and for drawing cables.

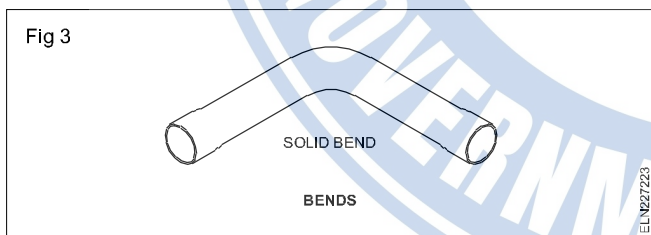

### Tees (Fig 4)

Tees are used to take diversion from the main line either to the switch points or the light points. It may be either an ordinary type or an inspection type. Inspection type tees are used to assist in the inspection in case there is a need.

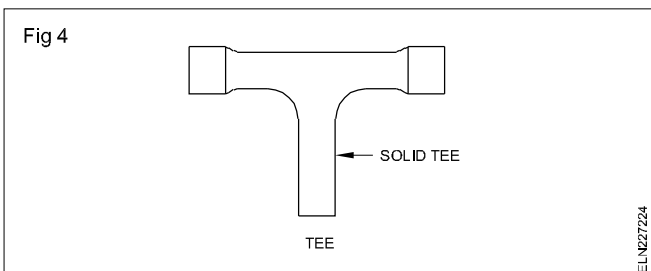

### Circular boxes (Fig 5)

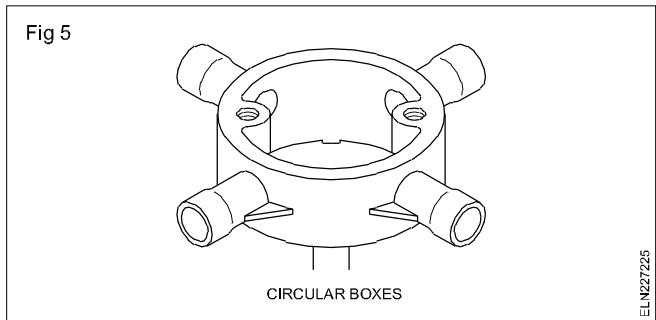

Small circular boxes shall be provided with two machine screws of a diameter not less than 2.8 mm for fixing the covers. Large circular boxes have four machine screws of not less than 4 mm diameter having not less than 10mm threaded portion for fixing the cover.

They are available in a single-way, two-way, three-way and four-way as well as back outlet types which can be used as per necessity in wiring. The minimum depth of junction boxes used in roof slabs shall be 65 mm. The cover of the circular box shall be made of the same material as that of the the box, and have a minimum thickness of 1.6 mm.

Apart from the above various other types are used as junction boxes. (Fig 6)

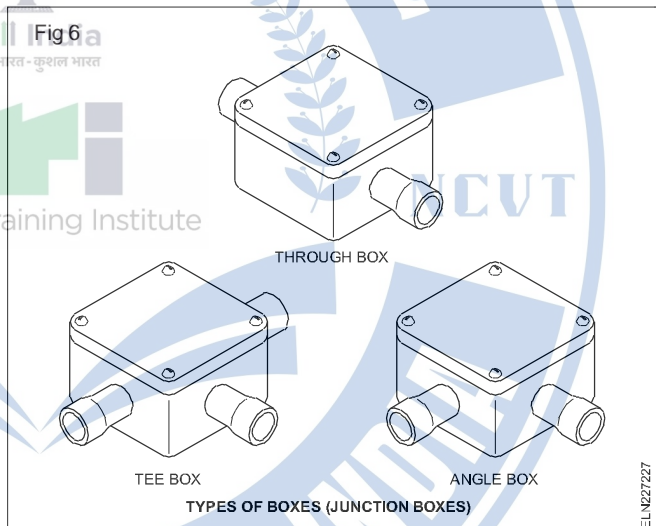

### Method of cutting, joining and bending PVC conduit pipes

While doing the conduit wiring, it becomes essential, that the length has to be increased or decreased. Further the conduit is to be bent according to the required situation.

#### Cutting PVC conduit

A PVC conduit is easily cut by holding at the corner of a bench and using a hacksaw. Any roughness of cut and burrs should be removed with the aid of a knife blade/emery sheet, or sometimes by using a reamer. Before installing the PVC conduit pipe great care should be taken to remove the burrs inside the pipes to avoid damage to the cables during the cable drawing process.

## Joining conduit with fittings

The most common jointing procedure uses a PVC solvent adhesive. Before applying the adhesive the inner surface of the accessory and the outer surface of the PVC pipe shall be cleaned with emery sheet to have a better grip. The adhesive should be applied to the receiving portion of the conduit fitting, and the conduit twisted into it to ensure a total coverage.

Generally, the joint is solid enough for use after two minutes although complete adhesion takes several hours. In order to ensure a sound joint, the tube and fittings must be clean and free from dust and oil.

Where expansion is likely and adjustments become necessary a mastic adhesive should be used. This is a flexible adhesive which makes a weatherproof joint, ideal for surface installations and in conditions of wide temperature variation. It is also advisable to use the mastic adhesive where there are straight runs on the surface exceeding 8 metres in length.

**Conduit fittings should be best avoided, as far as possible, on outdoor systems.**

### Bends in conduit

All bends in the non-metallic system shall be formed either by bending the pipes by proper heating or by inserting suitable accessories such as bends elbows or similar fittings. Solid type fittings shall be used for recessed wiring. Solid type/inspection type of fittings shall be used for surface conduit wiring.

The minimum bending radius of conduits shall be 7.5 cm. Care should be taken while bending the pipes to ensure that conduit pipes are not damaged or cracked and the internal diameter is not effectively reduced.

In recessed conduit wiring, conduit bending, other than at the ends, shall be made by bending the pipes to the required angle and clamping at short intervals. In the case of conduits laid in the roof slab, it can be clamped or tied to steel reinforcement bars with suitable metallic clamps.

In the case of conduits recessed on walls, the chasis shall be made in the required shape and conduit fixed in the groove with suitable clamps. In the case of bending for surface conduit system, bending can be done either at cold state or by proper heating.

### Bending PVC conduit in cold weather (Fig 7)

In cold weather it may become necessary to warm the conduit slightly at the point where the bend is required. One of the simplest ways to do this is to rub the conduit with the hand or a cloth. The PVC will retain the heat created long enough for the bend to be made. In order that the bend is maintained at the correct angle, the conduit should be saddled as quickly as possible.

### Bending of conduit by heating

The piece of conduit to be bent is first cut and inspected for any sharp edges or burrs left out. In such cases it shall be made smooth by using suitable emery sheet. The conduit is then filled with river sand. The ends are sealed

with suitable dummy covers. The portion where the bend is to be made shall be heated uniformly (Fig 8a) to a temperature below its melting point.

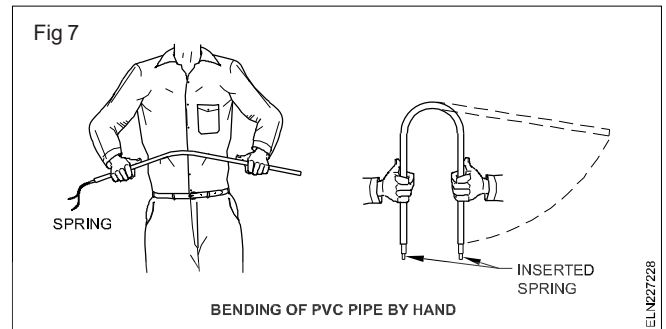

Then bend the required angle is made by holding both sides, with sufficient gap from the heated portion to avoid burning of hands, and applying uniform pressure (Fig 8b). Care shall be taken to avoid kinks on the conduits while bending.

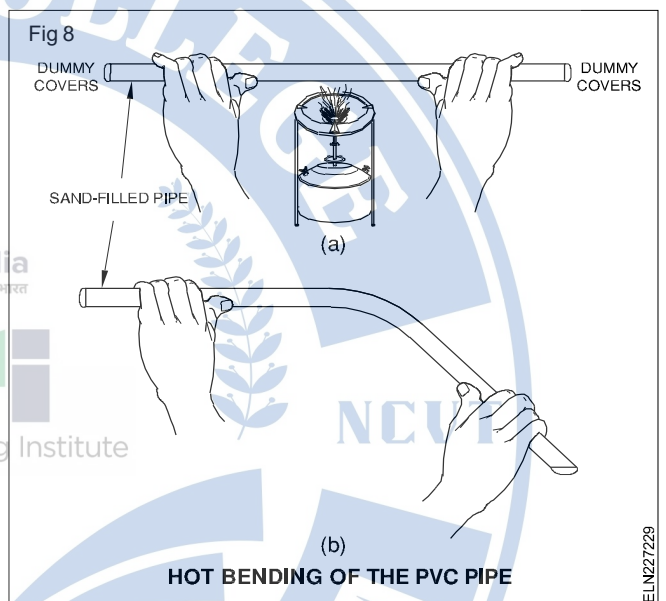

In PVC conduit wiring the first step is to select the correct size of conduit. The conduit size is determined by the size of cables and the number of cables to be drawn in a particular section. This information can be obtained from the wiring layout and the wiring diagram.

### Selection of conduit size

A non-metallic conduit pipe, used in wiring, should have a minimum size of 20 mm in diameter. Where a large number of conductors are to be drawn, the size of the diameter depends on the size of the conductor and the number of conductors. Table 1 gives details of the numbers and the sizes of conductors that can be drawn in each size of a non-metallic conduit.

When 2.5 sq mm 650 V grade single core cables of six numbers are to be drawn in a single run, we can use 25 mm non-metallic conduit as per the table.

When 6 sq mm. 650 V single core 6 cables are to be drawn in a single pipe we can use 32 mm PVC pipe. The following are the maximum permissible number of 650/1100V volts grade single core cables that may be drawn into rigid non-metallic conduits (Table 1).

TABLE 1

Maximum number of PVC insulated 650 V/1100 V grade aluminium/copper conductor cable drawing through conduits conforming to IS: 694-1990.												
Nominal Cross-sectional area of conductor in sq.mm	20 mm		25 mm		32 mm		38 mm		51 mm		70 mm	
	S*	B*	S	B	S	B	S	B	S	B	S	B
1.50	5	4	10	8	18	12	–	–	–	–	–	–
2.50	5	3	8	6	12	10	–	–	–	–	–	–
4	3	2	6	5	10	8	–	–	–	–	–	–
6	2	–	5	4	8	7	–	–	–	–	–	–
10	2	–	4	3	6	5	8	6	–	–	–	–
16	–	–	2	2	3	3	6	5	10	7	12	8
25	–	–	–	–	3	2	5	3	8	6	9	7
35	–	–	–	–	–	–	3	2	6	5	8	6
50	–	–	–	–	–	–	–	–	5	3	6	5
70	–	–	–	–	–	–	–	–	4	3	5	4

\* The above table shows the maximum capacity of conduits for a simultaneous drawing in of cables.

\* The columns headed 'S' apply to runs of conduits which have a distance not exceeding 4.25 m between draw in boxes and which do not deflect from the straight by an angle of more than 15 degrees. The columns headed 'B' apply to runs of conduit which deflect from the straight by an angle of more than 15 degrees.

\* Conduit sizes are the nominal external diameters.

## PVC Channel (casing and capping) wiring

**Objectives:** At the end of this lesson you shall be able to

- state the use limitation and rules of channel wiring system
- select the channel size according to size and number of cables from the chart
- explain the method of fabricating neutral, bend, and junction in PVC channel .

**Introduction :** Channel (Casing and Capping) wiring is a system of wiring in which PVC/metallic channels with covers are used for drawing wires. This system of wiring is suitable for indoor surface wiring works. This system is adopted to give a good appearance and for extension of existing wiring installation. PVC insulated cables are generally used for wiring in casing and capping system. This is otherwise called 'wireways'.

The channel and top cover shall be of the same material either PVC or anodised aluminium. The casing is square or rectangular in shape. The capping shall be slide in type

with double grooving in the case of PVC wire ways. Plain type capping are used for metallic wireways.

The only disadvantage in a channel wiring is that it is inflammable and risk of fire.

**Dimensions :** The sizes of channel, the maximum number of wires which can be drawn in each size are given in the table 1 below.

The thickness of channel should be 1.2mm ± 0.1mm.

Table 1

Nominal cross sectional area of conductor in sq.mm	10/15mm x 10mm size channel	20mm x 10mm size channel	25mm x 10mm size channel	30mm x 10mm size channel	40mm x 20mm size channel	50mm x 20mm size channel
	No. of wires	No. of wires	No. of wires	No. of wires	No. of wires	No. of wires
1.5	3	5	6	8	12	18
2.5	2	4	5	6	9	15

4	2	3	4	5	8	12
6	-	2	3	4	6	9
10	-	1	2	3	5	8
16	-	-	1	2	4	6
25	-	-	-	1	3	5
35	-	-	-	-	2	4
50	-	-	-	-	1	3
70	-	-	-	-	1	2

### Precautions

- 1 Neutral (Negative) cables should be carried in top channel and phase (Positive) in the bottom channel.
- 2 Crossing of cables between phase (Positive) and neutral (Negative) should be avoided.
- 3 Porcelain or PVC pipe should be used for crossing the cables through the walls.

**Installation of PVC channel :** The channel should be fixed to wall/ceiling with flat headed screws and rawplugs. These screws shall be fixed at an interval of 60cm. On either side of joints this distance shall not exceed 15cm from the end point. Channel under steel joints shall be fixed with MS clips of not less than 1.2mm (18SWG) thickness and width not less than 19mm.

**Floor/Wall crossings :** When conductor pass through floors/wall the same should be carried in a steel conduit/ PVC conduits properly bushed at both ends. The conduits shall be carried 20cm above floor level and 2.5cm below ceiling level and properly terminated into the channel.

**Joints in PVC/Metal channel :** As far as possible wireways in straight runs should be single piece. All joints shall be scarfed or cut diagonally in longitudinal section. The section ends shall be filed smoothly but joined without any gap. Care shall be taken to see that the joints in PVC cover does not overlap those channel.

Joints shall also be done using standard accessories like elbows, tees, 3 ways/4 ways junction box etc of high grade PVC/Aluminium alloy. In PVC channel separate channel cover for joint, elbows, tees, cross etc are available. These can be fixed after fixing the channel to give a good appearance. The radius of curvature of the cables inside a bend should be more than 6 times its over all diameter.

In the case of PVC channel, making joints is comparatively easy. Mark the joints by placing the two pieces in required angle. Identify the position to be cut and remove on each pieces. Cut through the lines and file the edges to get gapless joint.

### Fabricating a right-angled vertical bend

- 1 Mark out the position of bend of all sides as shown in Fig 1. the width 'Y' must be made equal to the diagonal length 'Y' to be cut.
- 2 Drill small holes in corners at point of bend to stop channel folding (Fig 1).

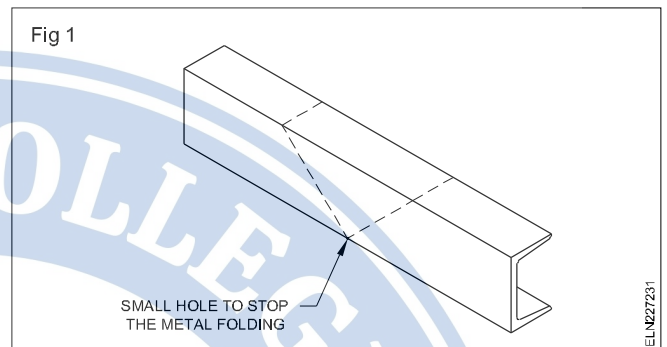

- 3 Place wood blocks inside trunking for support. Cut sides of trunking (Fig 2).

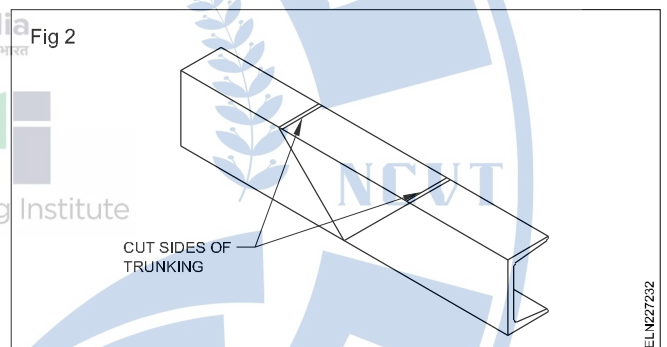

- 4 Cut, file and break-off waste (Fig 3).

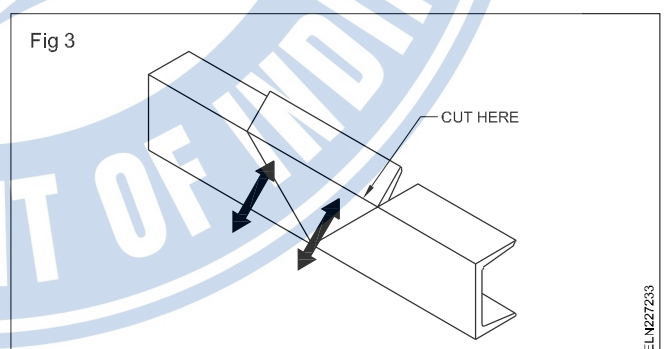

- 5 File all the edges smooth in order to bend to shape (Fig 4).
- 6 Make 'L' plates out of PVC scrap (Fig 5).
- 7 Make and secure assembly with 'L' plates and paste it with suitable adhesive (Fig 6).

### Fabricating 90° bend

- 1 Mark out the position of bend (Fig 7a & b).

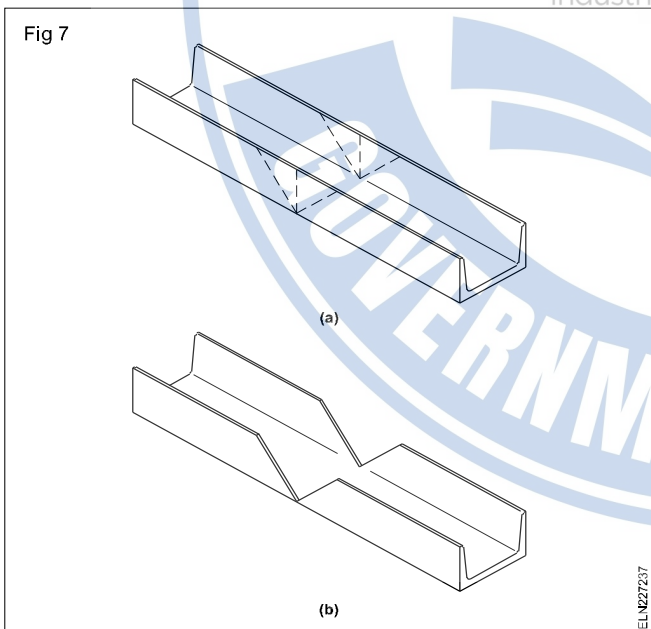
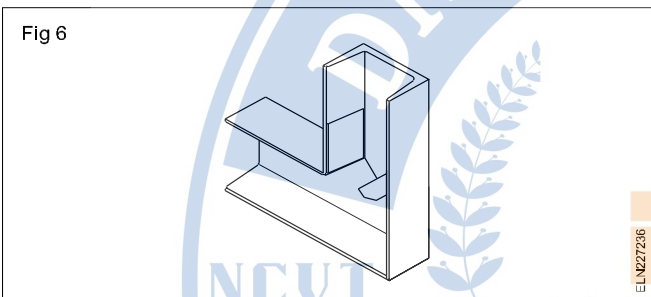
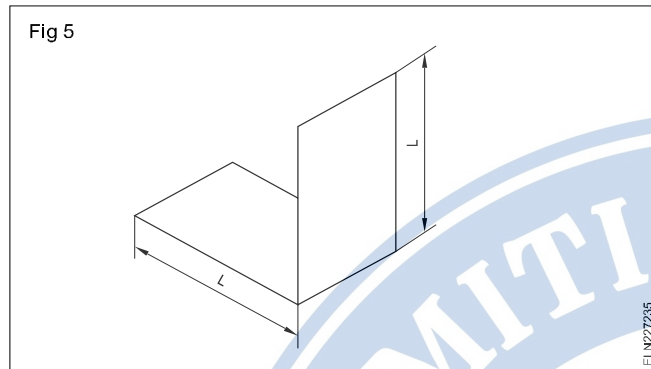
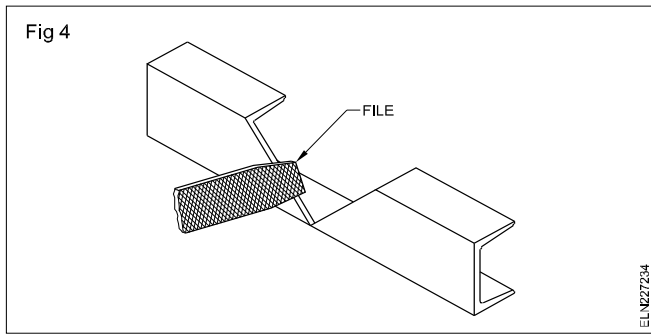

- 2 Place wood blocks in trunking for support and make cuts with hacksaw.
- 3 Remove sections and file smoothly.
- 4 Bend shape and adjust the fit as required (Fig 8a, b & c).
- 5 Make fish plates from PVC scrap (Fig 8b).

6 Make and secure the assembly with fish plate (Fig 8).

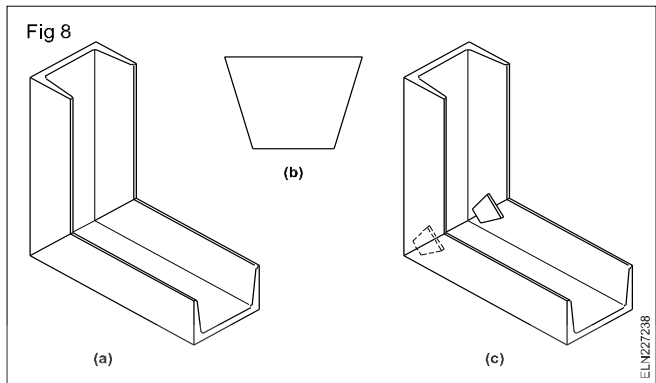

### Fabricating a Tee junction

- 1 Mark out the position of tee using another piece of trunking to gauge width
- 2 Cut out the space for the tee (Fig 9a). Blocks of wood should be used to support section being cut.
- 3 In another piece cut away the section (Fig 9b) to form two legs (Fig 9c).

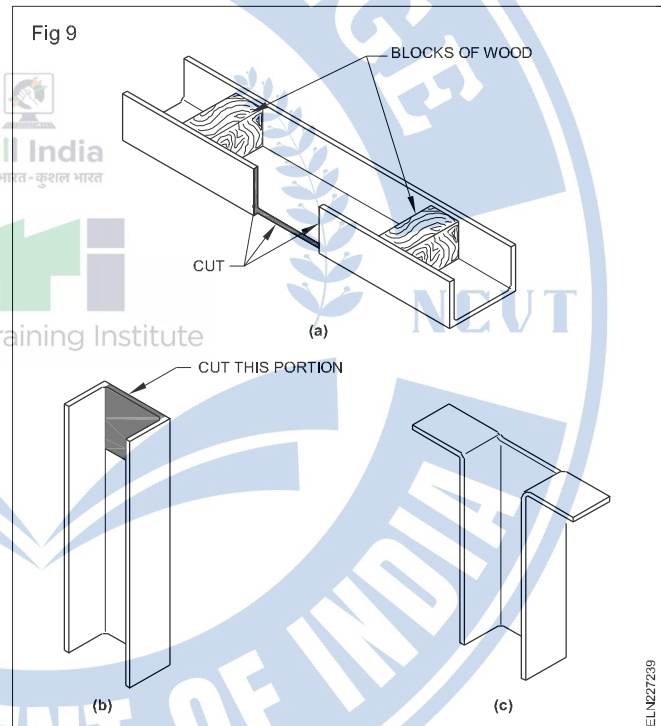

- 4 File edges smooth and remove burrs. Check fit and adjust as necessary.
- 5 Make, assemble and secure the Tee junction using suitable adhesive (Fig 10).

**Installation of cables :** Cables carrying the direct current or alternate current shall always be bunched separately so that the outgoing and return cables are drawn in the same channel. Clamps shall be provided to hold the wires inside the channel at suitable intervals, so at the time of opening of the cover of channel, the wires do not fall out.

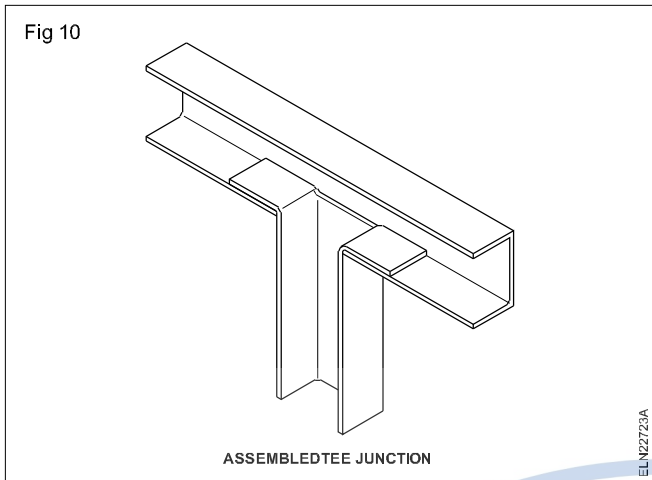

**Attachment of cover :** Cover should be attached to channel in individual sections after drawing all wires inside. No screws or nails shall be used for fixing PVC capping (cover) to the casing (channel). The capping (cover) should be slid in through the grooves. Metallic capping (cover) shall be fixed by using cadmium plated screws in a staggered manner with axial spacing not exceeding 30cm.

**Earth continuity conductor :** Earth continuity conductor shall be drawn inside the casing and capping (channel) for earthing of all metallic boxes of the installation as well as for connecting to earthpin of the socket.

## Power wiring

**Objectives:** At the end of this lesson you shall be able to

- state the power, control, communication and entertainment wiring.

A panel wiring diagram usually gives information about the relative position and arrangement of devices and terminals of the devices to help in installing or servicing the device.

Generally all the control panel / commercial / industrial wiring invariably consists of two sections viz control wiring and power wiring.

Fig 1 shows the typical layout diagram of a motor wiring. The control panel consisting of all the control and protective devices installed near to the power source and the load like, furnace, compressor etc, are installed away from the power source / panel boards.

Power wiring is a high current carrying circuit which is wired to connect / disconnect the load like motors/ furnace through the protective devices like OLR and fuses etc..

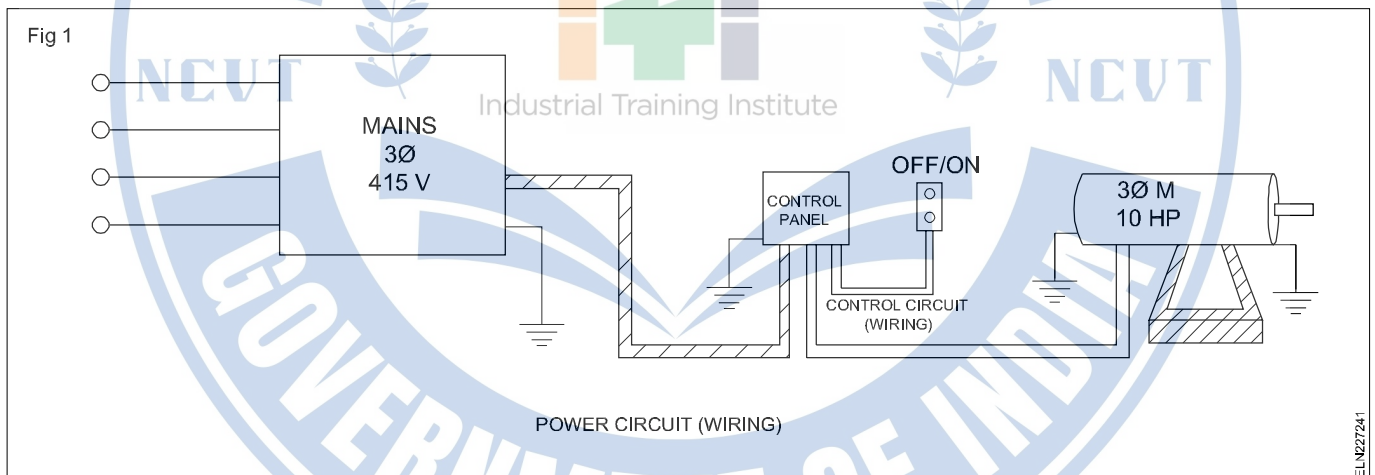

Power wiring has to be done as per the guideline and rules specified in IE rules. The cable size depends on the load current and it varies according to the load.

The power and control cable should not be run into single conduit. As the current radiation influences the control cable, a separate conduit to be provided for control and power cables.

### Control wiring

Control wiring is a circuit which is wired to communicate the commands and other information between control devices and lighting.

Control wiring enables the control circuit for various control purpose. In a motor control unit the control circuit is wired and kept near to motor. In other system such as fire alarm,

fire detector etc. The control circuit is wired separately with low current carrying conductors and drawn separately for easy maintenance.

### Fire alarm

The purpose of fire alarm system is to provide an immediate alarm in case of any fire and to prevent loss of life, also to secure the immediate attention of fire fighting staff.

### Fire detectors

The three principal fire detection method involve sensing the heat, presence of flame or smoke. The third method identifies the pre - fire condition that is a flammable gas detector, which is technically not a fire detector and its use is limited to places where flammable gases are likely to be present.

## I Heat detector

The three basic operating principles for heat detection are:

- a Fusion detector (melting of a metal)
- b Thermal expansion detector
- c Electrical sensing

## II Smoke detectors

There are three types of smoke detectors namely

- 1 Ionisation detector
- 2 Light - scattering smoke detector
- 3 Obscuration smoke detector.

## III Flammable gas detector

A flammable gas detector is designed to measure the amount of flammable gas in the atmosphere. The gas mixture is drawn over a catalytic surface where oxidation i.e. combustion takes place. The combustion causes a rise in temperature of the surface which is measured by a decrease in its electrical resistance. The instruments are calibrated by considering pentane or heptane as reference gas. The readings are displayed in terms of percentage of lower explosive limit.

### Control panel for fire alarm system

The control panel is the heart of the system through which the fire alarm system is monitored and alarm is initiated if any indication/signal is conveyed to the panel.

**The working of the fire alarm system should be checked once in a month regularly.**

The features of the control panel are the power supply, battery charging unit and control card.

### Communication wiring

It is type of wiring which is used to transmit the voice, data, images and video etc to the desired places.

Some of examples are

- Telephone wiring
- Internet / LAN network wiring
- Cable TV and other entertainment wiring
- Data and security services wiring
- Telex/ Fax machines wiring

Faster and more reliable than ordinary phone wiring, low-cost, high-tech copper wiring should serve every room in the modern home. Its is required to carry voice, data and other services from where they enter the house to every room, and from any one room to any other.

### Necessity of communication wiring

Unshielded twisted pair (UTP) copper information wiring often called structured wiring is used today for offices, schools and factories to provide local area networks (LANs), which allow computers to talk to one another and to receive and send Internet and high-speed computer data outside the facility.

Educated homebuyers-and homebuilders realize it is better to use the most advanced wiring technology up front, when installation is economical.

It's better to anticipate the homeowner's future needs by wiring the house with a state-of-the-art system while it is being built, and at the same time equip yourself with a powerful marketing tool.

The phone wiring of the past, often referred to as quad wiring because it has four copper wires, is now obsolete. Cat 5 or higher speed wiring has four twisted wire pairs, or eight wires.

### Copper UTP Wiring

Copper UTP wiring contains eight color-coded conductors (four twisted pairs of copper wires). It offers greatly increased bandwidth compared with old-fashioned quad wiring.

The cable is small (roughly 3/16 inch in diameter), inexpensive and easy to pull, although it must be handled with care.

### Advantages

Modern copper UTP wiring offers the following advantages:

#### Diversity

The Internet and computer communications, as well as ordinary phone signals, can be carried throughout the home on modern, inexpensive, high-speed, UTP cables. (To service a large number of TV channels, it is recommended to also run high-quality coaxial cable, such as quad-shielded RG-6.)

#### More phone numbers

Several phone numbers can be made available throughout the house. Actually, voice service requires very little bandwidth, and the addition of separate numbers is almost trivial.

Fig 1 is a simplified plan of a small, two-bedroom, single-story house. Note that all the wiring radiates from a single distribution device the star pattern and there are multiple outlets in each major room, including the kitchen and the porch.

#### Entertainment wiring

It is a type of wiring which is mainly used for entertainment or relaxation purpose.Example Home theatre wiring.

The nature and quality of wiring will not only determine the level of safety in home theatre room, but equally important, will have a noticeable impact on the video and sound quality of your system components.

### Home Theatre Wiring Basics: Safety, planning, budgeting

When it comes to home theatre wiring, the guiding principle is...

- Do it safe
- Do it once
- Do it right

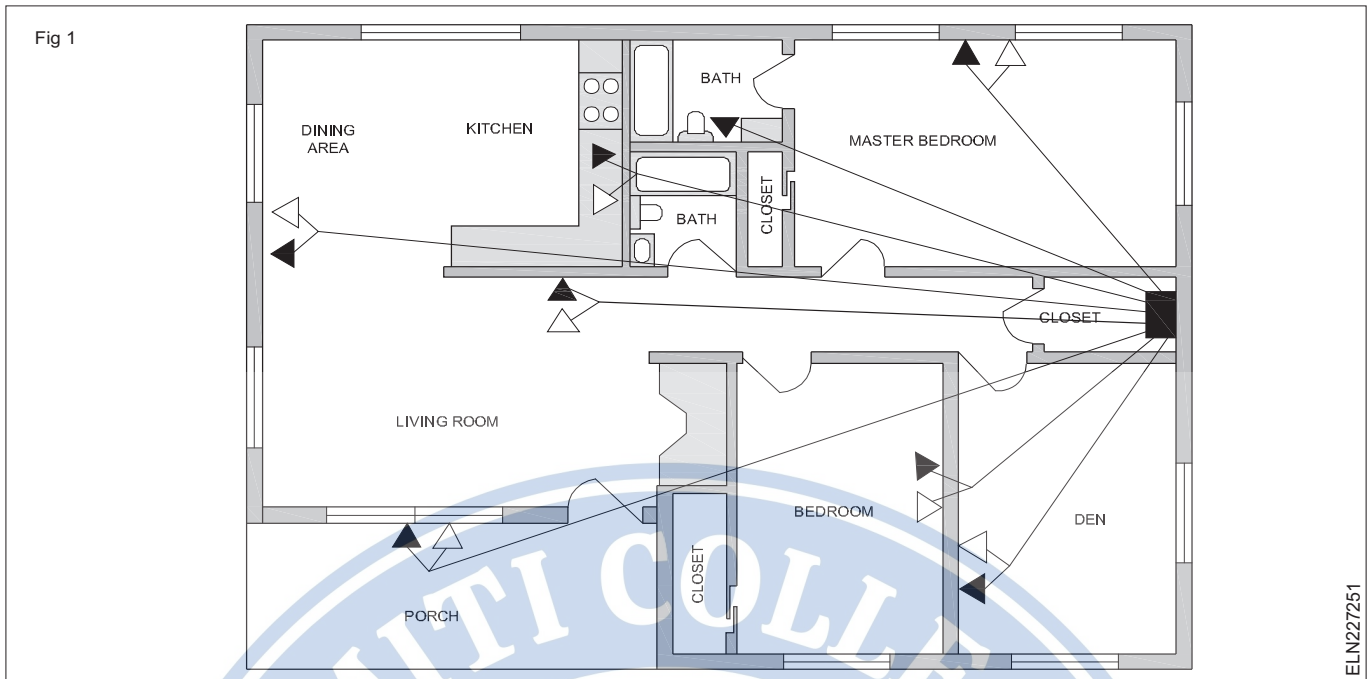

**Safety:** This is a most important aspect in any installation. Do not save on the wiring by using sub-standard cables.

With in-wall installations, Specially certified wires (UL-rated CL3 wires) should be used that comply with national standards for resistance to fire, chemicals, abrasion, and temperature extremes.

**Planning:** Planning is the key to future proofing the installation while avoiding costly alterations later on.

AV (Audio Video) equipment and speaker placement the room lighting requirements, networking, possible future additions, etc. are to be taken care of these will determine the quantity and placement of the various audio/video points in the room as well as the electrical needs for home theatre installation.

Finally, when it comes to estimating the required cable lengths, do not just calculate the linear lengths to complete your cable runs; allow for at least 20% extra to cover for possible errors and slack for terminations.

### Home Theatre Speaker Wiring

Many fail to realize that home theatre wiring can have a noticeable impact on speaker performance. The greatest speakers will not sound their best with the use of inappropriate speaker wires or an incorrect wiring installation. In particular, selecting the correct speaker wire thickness is essential for the best speaker performance.

At the same time, keep in mind that some speaker manufacturers use non-standard connectors with their speakers; in these circumstances, use of optional third-part speaker wire and connectors may not always be an option unless you take the extreme route of splice your wiring.

### Speaker Wire Size

Selecting the correct thickness for your home theater wiring is important as it affects the speakers' performance; it will

impact the speakers' ability to deliver the explosive effects in home theatre sound.

### Single Room Installation

The thicker wire will help bring out fine musical detail in quality music systems, as well as deliver the explosive effects of surround sound.

In those situations where long speaker wire runs cannot be avoided, thicker wire helps reduce the overall resistance, and therefore amplifier load - leading to lower operating temperatures. This will result in improved sound quality and long-term stability.

After setting up a modestly priced home-theatre-in-a-box package, do not go for the more expensive thicker wire unless you plan an upgrade sometime in the future; using of gauge 16 speaker wire should suffice in this case.

### Connection Basics

Speakers and amplifiers/receivers normally come equipped with one of two types of connectors - spring terminals or binding post connectors.

Each speaker connection have two such terminals marked (+) and (-) to help you distinguish the two leads. Maintaining correct polarity all along your home theater wiring is important. For this reason, speaker wire and terminals are normally color coded black for the -ve terminal and red for +ve side.

Spring terminals will only accept pin connectors or tinned base wire ends. Instead, binding posts accept many types of connection, including pin, banana plug or spade.

### Guidelines for Home theatre wiring & installation

- Do not run home theatre cables in close proximity or parallel to other electrical lines, nor run your wiring around power supplies as these can lead to interference issues with both your audio and video system components.

**Special wiring circuits - Tunnel, corridor, godown and hostel wiring**

**Objectives:** At the end of this lesson you shall be able to

- state the difference between godown, tunnel and corridor, bank/hostel wirings
- draw the tunnel lighting / corridor / bank / hostel circuits
- prepare the mode chart for the above circuits.

**Staircase wiring:** In wiring one lamp controlled with one switch in a simple wiring circuit to begin with. However, one lamp controlled with two switches from two different places, known as staircase wiring in the very basic wiring. Fig 1 shows such a wiring where two double pole switches are used to control one lamp individually.

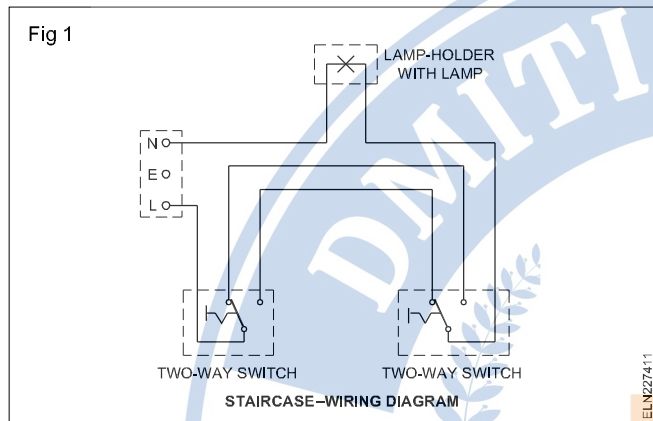

**Caution:** This circuit is not in accordance with IE rules as the phase and neutral come in the same switch. So care should be taken while connecting the wires.

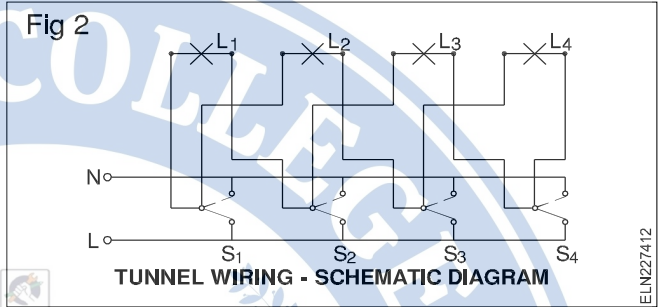

The mode of operation of the switches and the consequent lighting position are shown below.

**Mode chart for tunnel wiring**

SWITCHES				LIGHTS			
S <sub>1</sub>	S <sub>2</sub>	S <sub>3</sub>	S <sub>4</sub>	L <sub>1</sub>	L <sub>2</sub>	L <sub>3</sub>	L <sub>4</sub>
✓	✗	✗	✗	✓	✓	✗	✗
✓	✓	✗	✗	✗	✓	✓	✗
✓	✓	✓	✗	✗	✗	✓	✓
✓	✓	✓	✓	✗	✗	✗	✗

**MODE CHART FOR TUNNEL WIRING**

In the case of **godown wiring** we have seen that as you move inside the godown, you can switch on a lamp ahead of you while the light behind you is put off. The same process in the reverse order takes place while moving out of the godown.

But one light will not be sufficient to give enough illumination in the case of **tunnels** where darkness is more. Hence, the wiring circuit for a tunnel needs at least two lights to be 'ON' at a time while a person moves inside a tunnel and goes out.

Whereas in the case of **corridor wiring** the corridor may have a number of rooms occupied by different persons. When one moves toward his room, he needs a forward light to do so. The moment he finds the room and opens it, he may not need the corridor light. Then there should be an arrangement to switch off the light left behind the forward moving person and at the same time there should be a provision to switch off the light in front of his room. Such an arrangement is incorporated in corridor wiring.

**Tunnel lighting circuit (Fig 2)**

In tunnel wiring a person walking along the tunnel can successively light behind two lamps ahead and put off a lamp behind with one switch.

All switches are two-way switches.

**Corridor wiring (Fig 3)**

In this circuit, operating the first switch in one set makes the first light to switch on while operating the 2nd switch in the first set switches off the first light. This sequence goes on as explained in the mode chart.

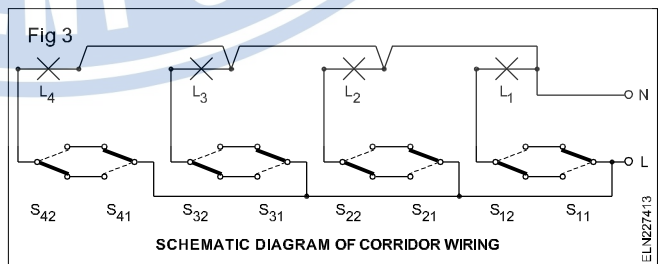

**Switch lamps chart**

SWITCHES								LAMPS			
1st SET		2nd SET		3rd SET		4th SET		L <sub>1</sub>	L <sub>2</sub>	L <sub>3</sub>	L <sub>4</sub>
S <sub>11</sub>	S <sub>12</sub>	S <sub>21</sub>	S <sub>22</sub>	S <sub>31</sub>	S <sub>32</sub>	S <sub>41</sub>	S <sub>42</sub>				
ON	-	-	-	-	-	-	-	✓	✗	✗	✗
ON	OFF	-	-	-	-	-	-	✗	✗	✗	✗
ON	OFF	ON	-	-	-	-	-	✗	✓	✗	✗
ON	OFF	ON	OFF	-	-	-	-	✗	✗	✗	✗
ON	OFF	ON	OFF	ON	-	-	-	✗	✗	✓	✗
ON	OFF	ON	OFF	ON	OFF	-	-	✗	✗	✗	✗
ON	OFF	ON	OFF	ON	OFF	ON	-	✗	✗	✗	✓
ON	OFF	ON	OFF	ON	OFF	ON	OFF	✗	✗	✗	✗

**MODE CHART FOR CORRIDOR WIRING**

**Godown lighting circuit**

Let us consider a godown lighting circuit (Fig 4) having four lamps L<sub>1</sub>, L<sub>2</sub>, L<sub>3</sub> and L<sub>4</sub> which are to be controlled such that if one moves in a godown in either direction he can switch ON one light after the other in the forward direction while the lamp which was lighted earlier gets switched OFF. In an arrangement, S<sub>1</sub> is a one way switch, S<sub>2</sub>, S<sub>3</sub> and S<sub>4</sub> are two-way switches.

While coming back from the godown when the person switches off the light 4, then the light 3 will be on and give light for his return movement. When he leaves the godown all the lights could be switched 'off' by operating switch S<sub>1</sub>.

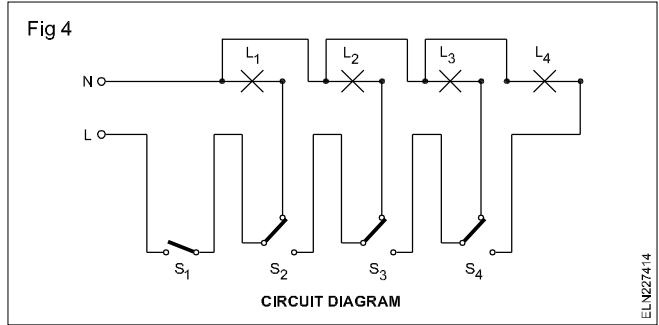

The following chart gives the mode of operation of the switches and lights. Trainees are advised to make the return mode chart.

**Mode chart for godown wiring**

Switches				Lights			
S <sub>1</sub>	S <sub>2</sub>	S <sub>3</sub>	S <sub>4</sub>	L <sub>1</sub>	L <sub>2</sub>	L <sub>3</sub>	L <sub>4</sub>
ON	OFF	OFF	OFF	ON	-	-	-
ON	ON	OFF	OFF	-	ON	-	-
ON	ON	ON	OFF	-	-	ON	-
ON	ON	ON	ON	-	-	-	ON

**Intermediate switch - Application in lighting circuit**

**Objectives:** At the end of this lesson you shall be able to  
 • draw diagrams of a lighting circuit using intermediate switches.

An intermediate switch is a special type of switch having four terminals for connection. This switch is commonly used to control a lamp or load from three or more positions as encountered in the lighting of staircases, corridors, bedrooms.

The schematic diagram (Fig 1) is for controlling one lamp from five locations using two two-way switches and three intermediate switches is given below.

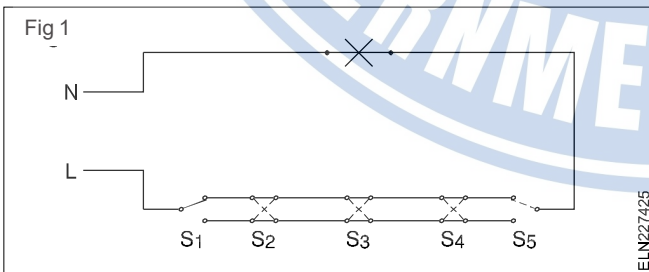

In the schematic diagram (Fig 2) is for controlling one lamp from 3 positions with a master control as a security control switch. The lamp is controlled independently from three

places by switches S<sub>1</sub>, S<sub>2</sub> and S<sub>3</sub>. When the master switch 'M' is 'ON' the lamp is permanently 'ON' and cannot be controlled by switches S<sub>1</sub>, S<sub>2</sub> and S<sub>3</sub>.

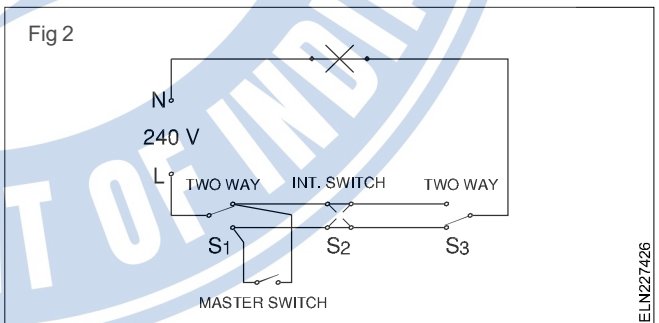

As intermediate switches are costly two numbers of two-way switches can be linked through a common bar and can be used as an intermediate switch. This circuit controls one lamp from 3 places.