

Dimensioning Practice - Types of arrowhead

Dimension line: These are thin continuous lines, terminated at ends by arrowheads, dots or oblique lines touching the extension line. (Fig 1)

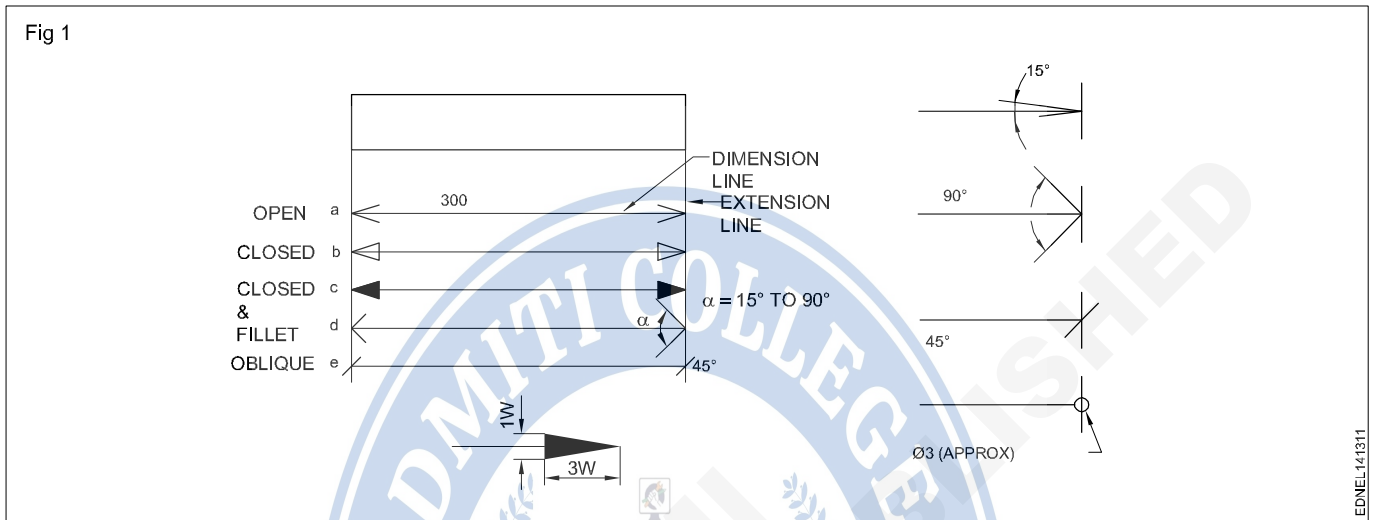

A dimension line may cut or cross another dimension line where there is no other way. Dimension to the hidden lines be avoided. (Fig 2)

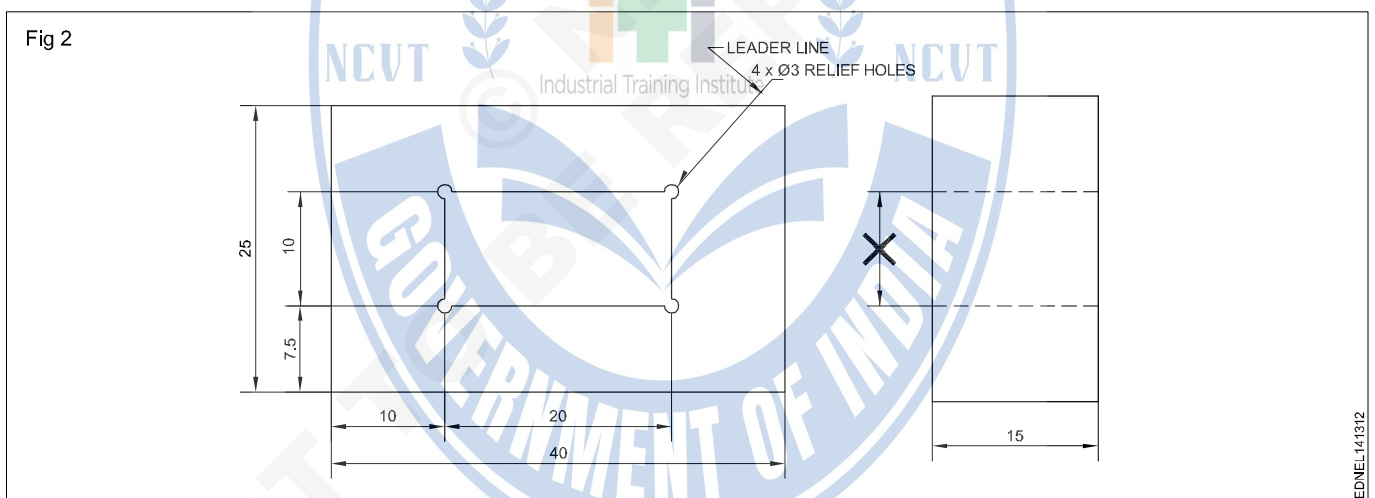

Arrowheads may be placed outside where space is insufficient.

Leader line: It is a thin continuous line. It connects a note or dimension with the features to which it applies. (Fig 2)

Termination and Origin indication: The size of the terminations (arrowheads/oblique strokes) shall be proportional to the size of the drawing. Only one style of arrowhead shall be used on a single drawing. However, where the space is too small for the arrowheads, it may be substituted by a dot or by an oblique line. Arrowheads are drawn as short lines forming barbs at any convenient

included angle between 15° and 90°. They may be open, closed or closed and filled in. Oblique strokes are drawn as short lines inclined at 45°. (Fig 1)

Indicating dimensional values on drawings: All dimensional values shall be shown on drawings in characters of sufficient size to ensure complete legibility on the original drawings as well as on reproductions made from micro-filming.

They shall be placed in such a way that they are not crossed or separated by any other line on the drawing.

Dimensioning - Position of dimensioning (aligned, unidirectional)

Definitions related to dimensioning

Dimension: It is a numerical value expressed as an appropriate unit of measurement and indicated graphically on technical drawings with lines, symbols and notes.

Dimensions are classified according to the following types:

Functional dimension (F): It is a dimension that is essential to the function of the component or space. They are generally shown with limits. (Fig 1)

Non-functional dimension (NF): It is a dimension that is not essential for the function of the component or space.

Auxiliary or Reference dimension (AUX/REF): It is the dimension given for information only. It is derived from the values given on the drawing or related documents and it will not be given for production or inspection. (Fig 1)

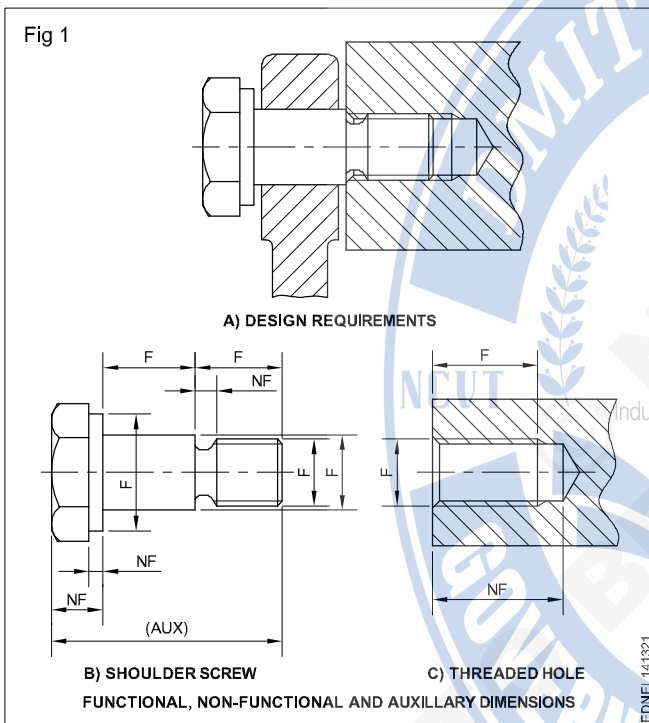

Methods of indicating values

Methods of indicating values: There are two methods used for indicating the values. Only one method should be used on anyone drawing.

Method 1 Aligned system

Dimensional values shall be placed parallel to their dimension lines and preferably near the middle, above and clear of the dimension line. However, values shall be indicated so that they can be read from the bottom of the drawing. Dimension lines should not be broken. Dimensioning of angles is also given in the same way. (Fig 1) This method is known as an **aligned system** of dimensioning.

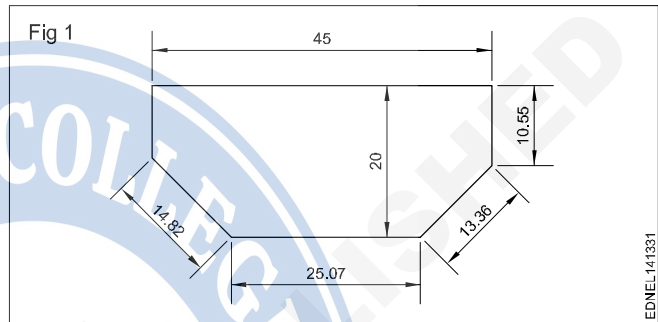





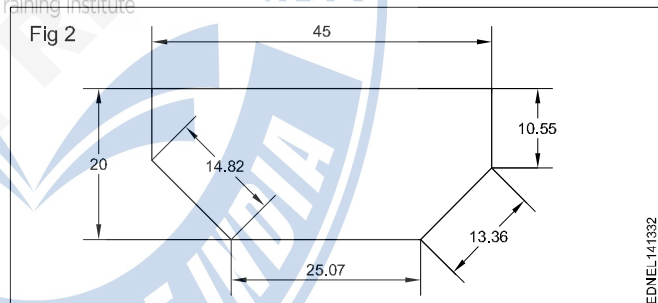





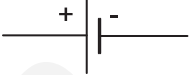



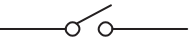

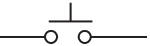
Method 2 Unidirectional system

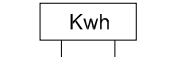
Dimensional values shall be indicated so that they can be read from the bottom of the drawing sheet. Non-horizontal dimension lines are interrupted, preferably near the middle so that the value can be inserted. (Fig 2). This method is termed a **unidirectional system** of dimensioning.

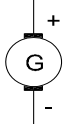

Symbolic representation - Different electrical symbols used in the related trades

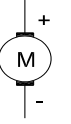
Sign and symbols for Electrical group trades



S.No.	Description	Symbol	S.No.	Description	Symbol
1	D.C.		11	Cell	
2	A.C.		12	Battery	
3	Positive		13	Single pole single throw switch	
4	Negative		14	Push-button switch	
5	Single Phase A.C. 50 Hz		15	Energy meter	
6	Three Phase A.C., 50 Hz		16	Alternator	
7	A.C. / D.C.		17	Generator	
8	3-Phase line		18	D.C. Motor	
9	Neutral line				
10	Earth				



S.No.	Description	Symbol
19	A.C.Motor Single phase	
20	3-phase squirrel cage motor	
21	3-phase slip ring motor	
22	Capacitor: Fixed, variable	
23	Electrolytic Capacitor	
24	Two-way switch	
25	Fuse: ordinary cartridge	
26	Socket 2 pin, 3 pin	
27	Aerial / Antenna	
28	Voltmeter	
29	Ammeter	

S.No.	Description	Symbol
30	Ohm Meter	
31	Watt Meter	
32	Lamp	
33	Electric bell	
34	Buzzer	
35	Connections: star, Delta	
36	Choke	
37	Transformers	
38	Resistor : Fixed	
39	Resistor: variable	
40	Diode	
41	Auto transformer	
42	SCR	

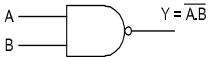
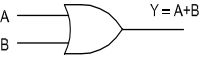
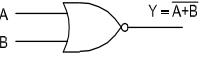
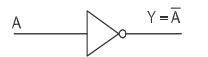
S.No.	Description	Symbol
43	UJT	
44	SPS T switch	
45	DPS T switch	
46	SPD T switch	
47	DPD T switch	
48	Single Pole 5 way rotary switch	
49	SPDT slide switch	
50	Relay contacts	
51	Transformer tapped secondary	
52	Shielded wire	
53	Zener diode	
54	Schottky diode	
55	Diac	

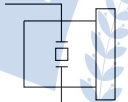
S.No.	Description	Symbol
56	SCR	
57	TRIAC	
58	PNP transistor	
59	NPN transistor	
60	FET N-channel	
61	FET P-channel	
62	Unijunction transistor	
63	LED diode	
64	Photo voltaic cell	
65	AND Gate	

S.No.	Description	Symbol
66	NAND Gate	
67	OR Gate	
68	NOR Gate	
69	NOT Gate	
70	EX-OR Gate	
71	EX-NOR Gate	
72	Piezo-electric buzzer	

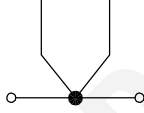
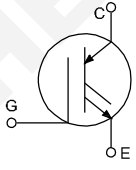
S.No.	Description	Symbol
73	Galvanometer	
74	Analog multimeter	
75	Thermo couple meter	
76	IGBT	
77	IC	