

Marking of straight lines, circles, profiles and various geometrical shapes and cutting the sheets with snips

Objectives: At the end of this exercise you shall be able to

- flatten a sheet using wooden mallet
- mark parallel lines, curved lines, circles and geometrical shapes
- cut sheet metal on straight lines using straight snips
- cut sheet metal on curved lines using curved snips
- cut sheet metal on various geometrical shapes.

Task 1

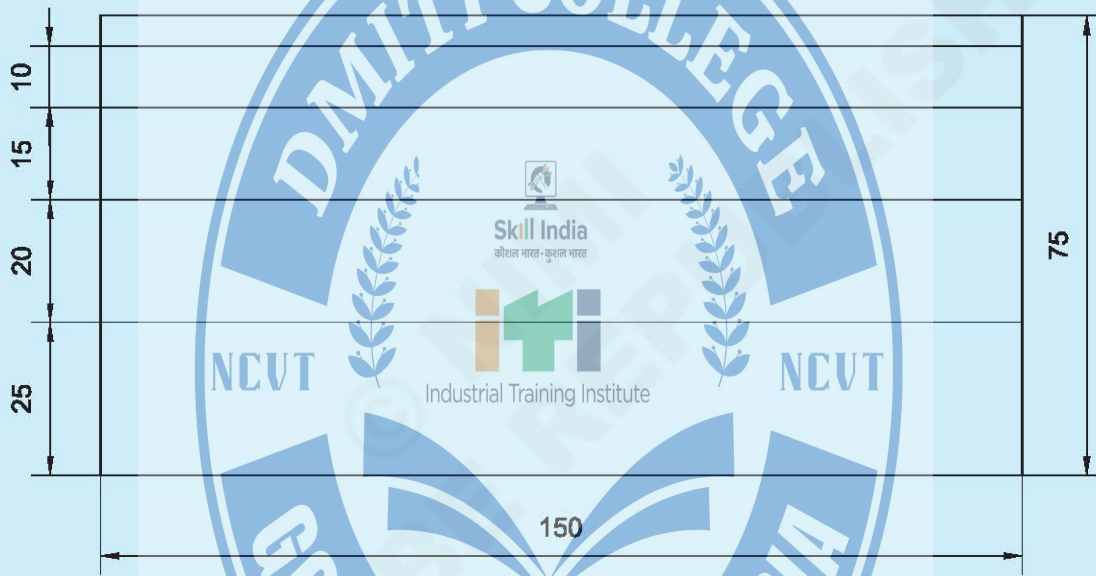

MARKING AND CUTTING ON STRAIGHT LINES

1	ISSH 105 x 105 x 1.00mm	-	G.I. SHEET	-	TASK 6	
1	ISSH 75 x 75 x 1.00mm	-	G.I. SHEET	-	TASK 5	
1	ISSH 75 x 75 x 1.00mm	-	G.I. SHEET	-	TASK 4	
1	ISSH 125 x 125 x 1.00mm	-	G.I. SHEET	-	TASK 3	
1	ISSH 105 x 105 x 1.00mm	-	G.I. SHEET	-	TASK 2	
1	ISSH 155 x 80 x 1.00mm	-	G.I. SHEET	-	TASK 1	1.3.42
NO.OFF	STOCK SIZE	SEMI-PRODUCT	MATERIAL	PROJECT NO.	PART NO.	EX. NO.

SCALE 1:1

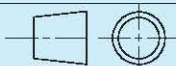

TITLE: **MARKING AND CUTTING VARIOUS GEOMETRICAL SHAPES IN G.I. SHEET**

DEVIATIONS ±1.00mm

TIME

CODE NO. F120N1342E1

TASK 2

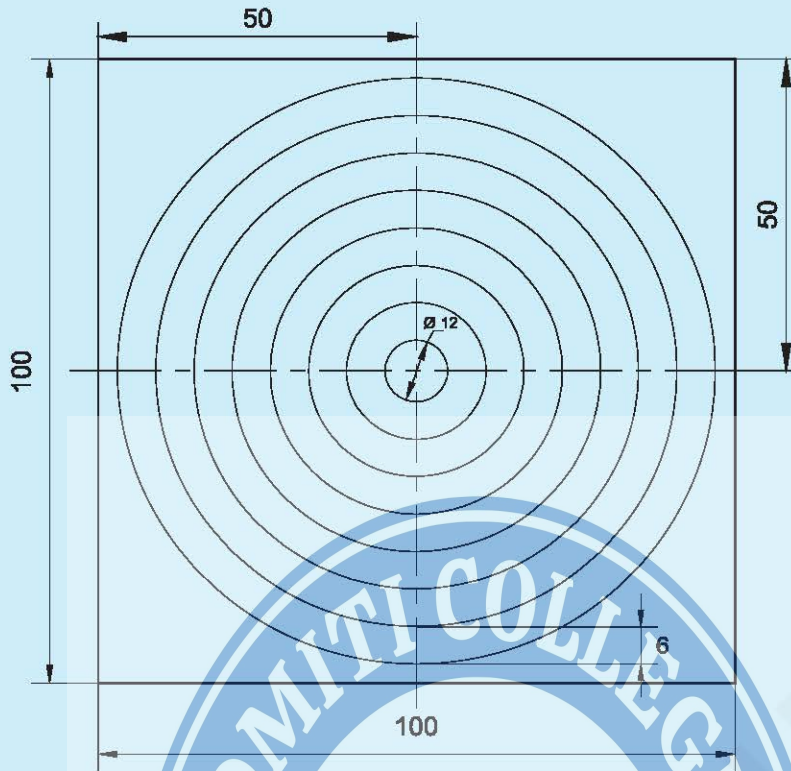

TASK 3

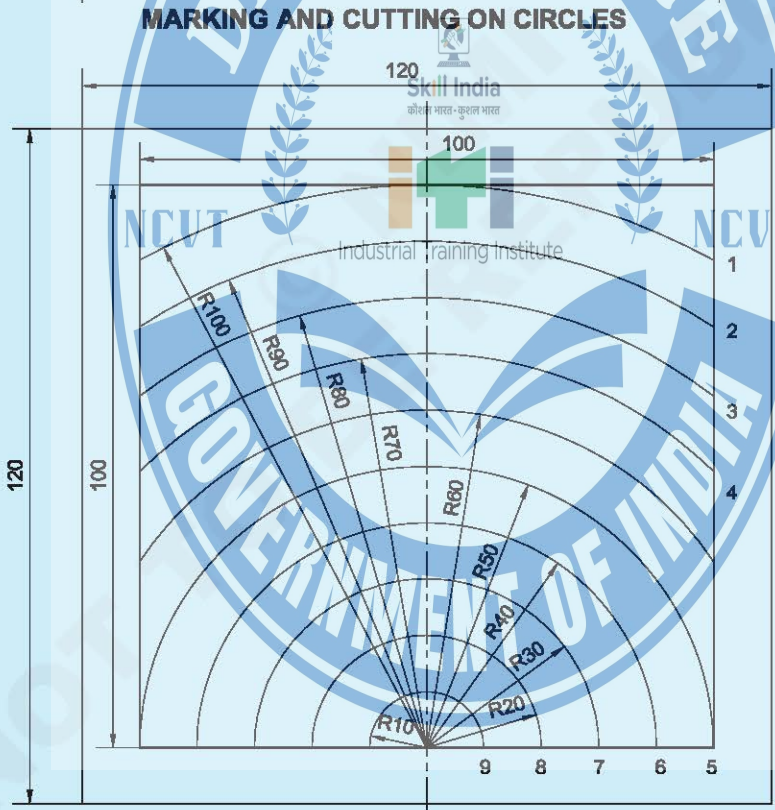

MARKING AND CUTTING ON CURVED LINES

		-	-	-	-	1.3.42
NO.OFF	STOCK SIZE	SEMI-PRODUCT	MATERIAL	PROJECT NO.	PART NO.	EX. NO.
SCALE 1:1	MARKING AND CUTTING VARIOUS GEOMETRICAL SHAPES IN G.I. SHEET				DEVIATIONS ±1mm	TIME
					CODE NO. F120N1342E2	

Task 4

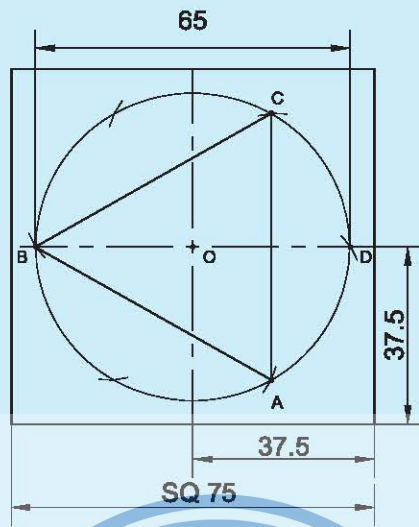

MARKING AND CUTTING TRIANGLE

Task 5

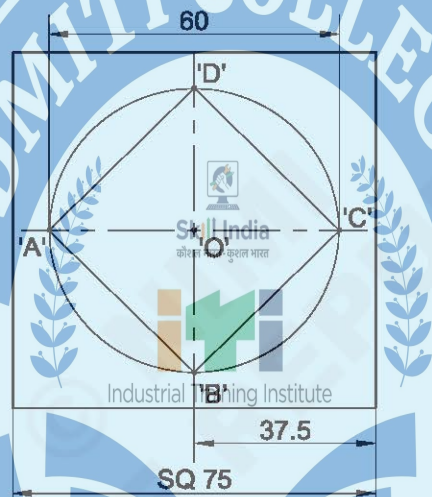

MARKING AND CUTTING SQUARE

Task 6

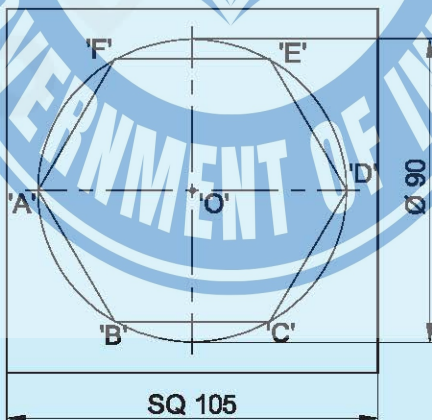

MARKING AND CUTTING HEXAGON

1	-	-	-	-	-	1.3.42
NO.OFF	STOCK SIZE	SEMI-PRODUCT	MATERIAL	PROJECT NO.	PART NO.	EX. NO.
SCALE 1:1	TITLE: MARKING AND CUTTING VARIOUS GEOMETRICAL SHAPES IN G.I. SHEET				DEVIATIONS ±1mm	TIME
					CODE NO. F120N1342E3	

Job Sequence

TASK 1: Marking and cutting on straight lines

Check the size of the sheet steel as per sketch using a steel rule.

Level the sheet on the workbench or a bench stake using a mallet.

Mark a rectangle on the sheet metal as per sketch using 'L' square, steel rule and scribe.

Set the steel rule on the outline of the sheet for 25mm.

Mark off two 'V' marks at 25mm from each long side.

Scribe a line through the 'V' marks, throughout the length of 150mm.

Similarly, mark other lines 20mm, 15mm, 10mm and 5mm apart from each other.

Hold the sheet by left hand.

Cut the sheet by the right hand on the line, using straight snips.

TASK 2: Marking and cutting on circles

Check the size of the square sheet as per sketch, using a steel rule.

Level the sheet on a levelling plate using a mallet.

Mark a square on sheet metal as per sketch.

Mark and punch the centre of the square sheet.

Draw $\varnothing 12\text{mm}$ concentric circle at the centre of square.

Similarly, scribe other 7 concentric circles with equidistant radius.

Cut the circle lines using bend snips.

TASK 3: Marking and cutting on curved lines

Flatten the sheet metal using a wooden mallet and a tinman's anvil stake.

Check the size of the sheet using a steel rule.

Mark square 100 x 100 using a steel rule, a straight edge and a 'L' square.

Mark the centre line as shown in Fig.1

Cut along the marked outside curved lines 1 to 4 using straight snips. (Fig.2)

Cut along the marked inside curved lines 5 to 9 using bend snips. (Fig.2)

Check the dimensions of the cut pieces using a steel rule.

Flatten the sheet on anvil stake with wooden mallet.

Check surface flatness with edge of steel rule.

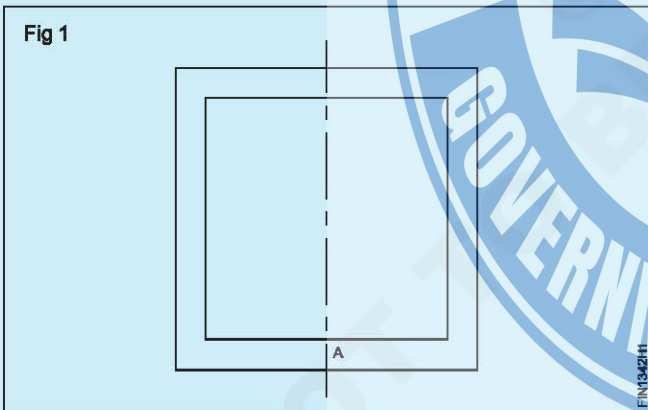

Mark point 'A' and punch using a dot punch and a ball peen hammer.

Taking point 'A' as the centre, mark curved line radius 10mm using a wing compass.

Similarly, mark other curved lines as per job drawing.

Check the marked curved lines using a steel rule.

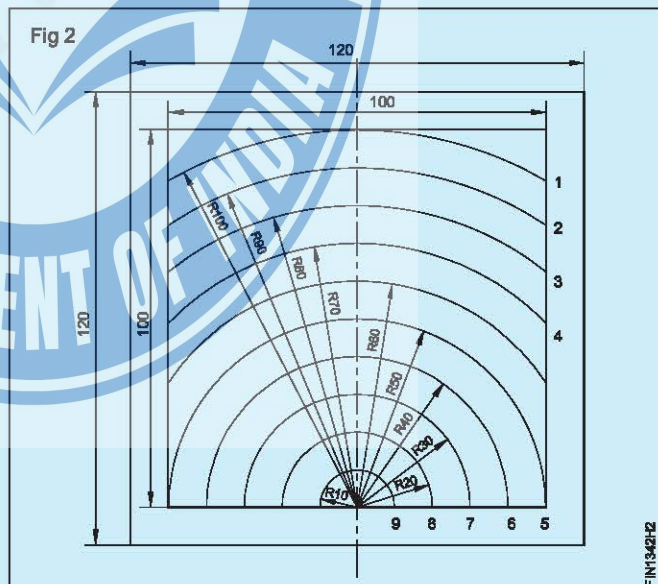

TASK 4: Marking and cutting triangle

Check the size of the sheet as per sketch using a steel rule.
Level the sheet on the bench stake using a mallet.
Punch the centre of the sheet by a prick punch.
Draw a $\varnothing 65\text{mm}$ circle using a divider on the sheet.
Punch a dot on the circumference of the circle by a prick punch.

Mark three arcs equal to the side of the equilateral triangle and join the arcs by lines.
Cut along the marked lines using straight snips.
Check the triangle size with steel rule.

TASK 5: Marking and cutting square

Check the size of sheet as per sketch using a steel rule.
Mark the centre lines.
Punch the centre of the sheet by a prick punch.

Draw a $\varnothing 60\text{ mm}$ circle using divider on the sheet at point 'O'.
Join points A, B, C, D and inscribe the square.
Cut along the marked lines using straight snips.

TASK 6: Marking and cutting hexagon

Check the size of the sheet as per sketch using a steel rule.
Level the sheet on a levelling plate.
Mark centre lines.
Punch at the centre of the sheet 'o'.
Draw $\varnothing 90\text{mm}$ circle.

Scribe arcs on the circumference, each arc being equal to the radius of the circle.
Join points A, B, C, D, E & F and construct the hexagon.
Cut along the marked lines using straight snips.

Skill Sequence

Flattening the sheet metal

Objective: This shall help you to
• **flatten the sheet metal of various sizes.**

Clean the tinman's anvil stake and the job.
Place the job on the anvil stake top. (Fig 1)

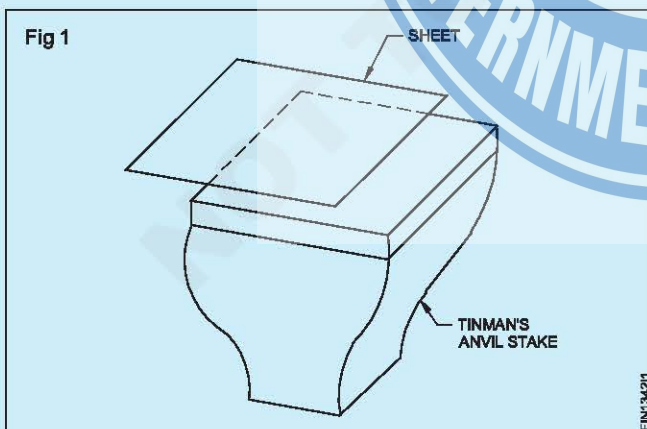

If the size of the sheet metal is smaller than the face of the stake, place the sheet somewhere in the middle of the stake face. (Fig 2)

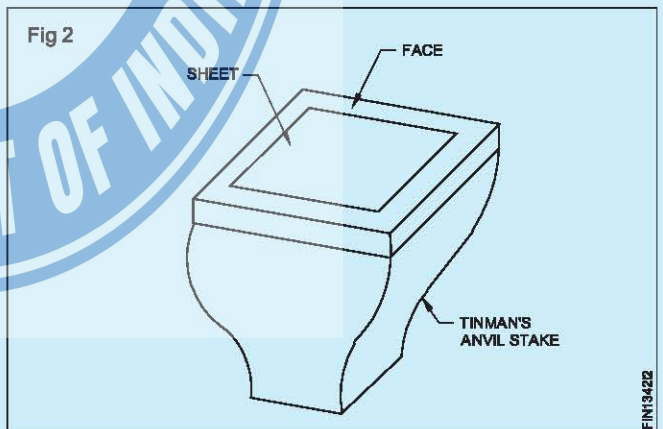

If the size of the sheet is bigger than the face of the stake, place the edge of the sheet at the center of the stake face.

Strike the sheet with the mallet from front to back and back to front, till the entire surface of the sheet is flat. (Fig 3)

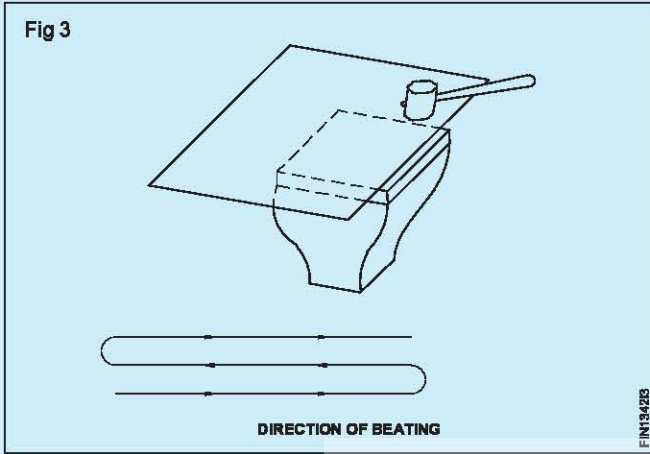

Check the flatness of the sheet metal with the edge of the steel rule. While checking the flatness, place the edge of the steel rule on the surface of the sheet and observe the gap between the steel rule edge and the surface of the sheet metal. (Fig 4)

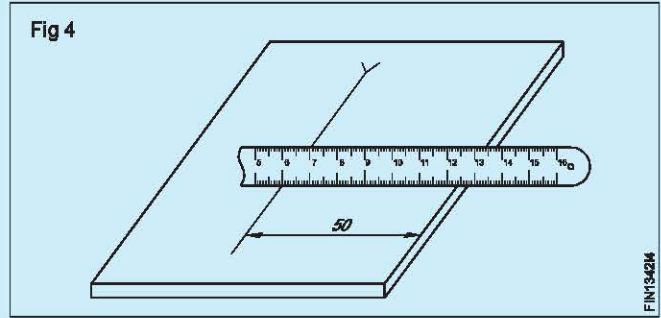

If a gap is not observed, then the sheet is perfectly flat.
If a gap is observed, then the sheet is not flat at the points of the gap.

Flatten the surface at the points of the gap if a gap is observed.

Measuring and marking the sheet metal

Objectives: This shall help you to

- measure the linear dimensions of the sheet metal using a steel rule
- mark parallel lines using a steel rule, a straight edge and a scriber.

Measuring

- Clean the edges of the steel rule using a waste cloth.
- Place the graduated edge of the steel rule on the workpiece such that the edge is perpendicular to the lines or the edges. (Fig 1)

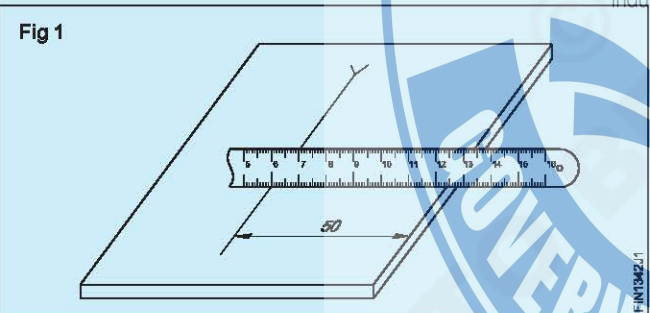

- Coincide one line with a large graduated line (Centimeter lines) on the steel rule.
- Taking this as a reference dimension, note the dimension on the scale coinciding with the line/edge between which the distance is to be checked.
- Determine the distance between the two lines. For example, if 50 mm is the reference dimension and 100 mm is the dimension coinciding with the line between which the distance is to be checked, then $100 - 50 = 50$ mm is the distance between the two lines.

Mark a straight line on the sheet: Mark off two 'V' marks from the datum 'xx' at a distance as required for measurement, using a steel rule and a scriber. Datum 'xx' is at right angle to datum 'yy'. (Fig 2)

Set the straight edge in between the 'V' marks and press the straight edge with your fingers. (Fig 3)

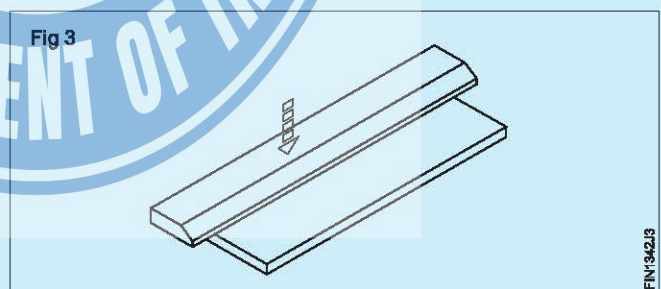
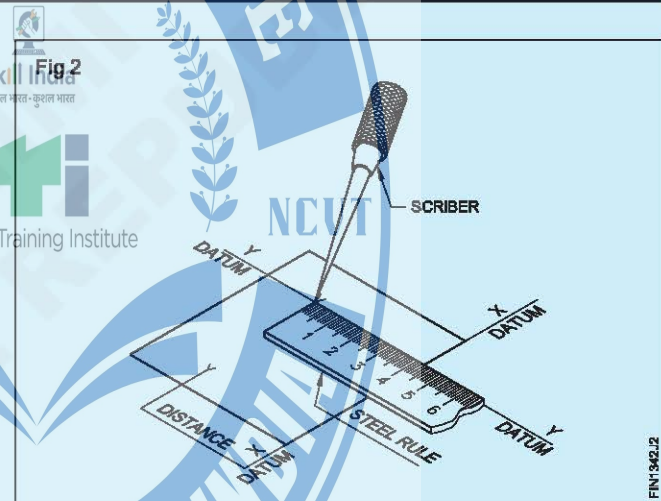

While scribing lines, hold the scriber close to the straight edge as shown in Fig 4.

Incline the scriber at an angle of 45° approximately as shown in Fig 5 and scribe a line towards you along the edge of the straight edge.

If the inclination is opposite from you, it will cause damage to the sheet and will remove the top layer of the metal.

Don't apply excessive pressure while scribing lines using the scriber to avoid the removal of the metal. Fig 6.

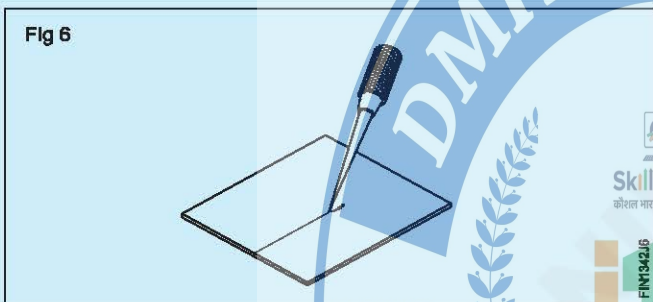
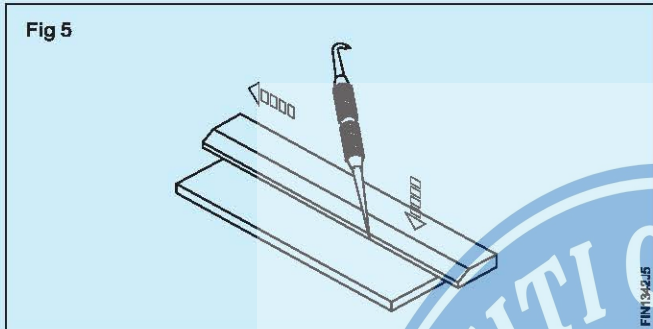
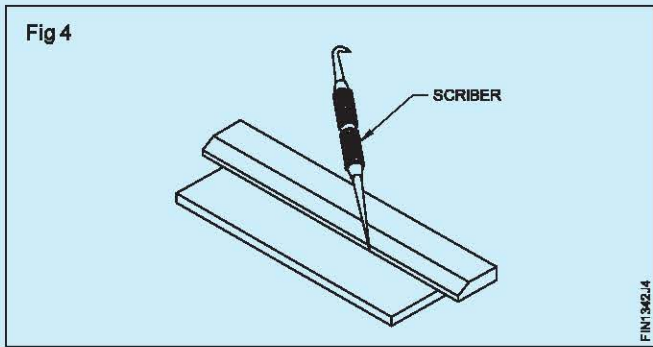

The line AB is the parallel line to the datum xx. (Fig 7)

For economical marking

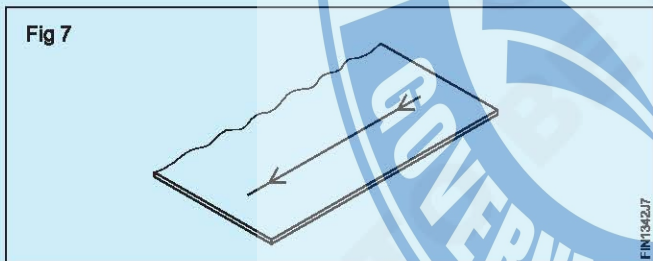

To avoid wastage, always scribe lines from left hand bottom corner as shown in Fig 8 but not as in Fig 9.

Draw parallel lines as in Fig 10 as per the dimensions shown in Job drawing. (Ref. Job sequence for Ex.No.1.3.42 Task 1.

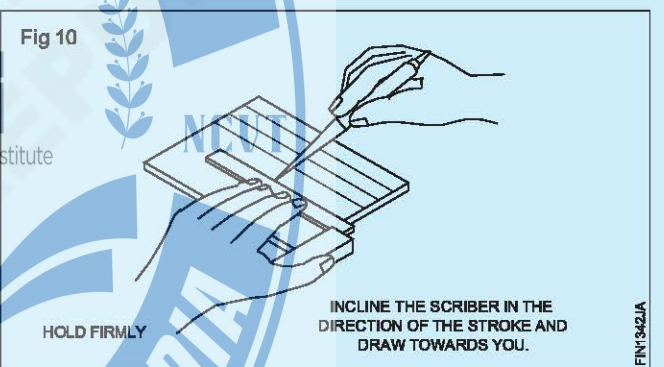
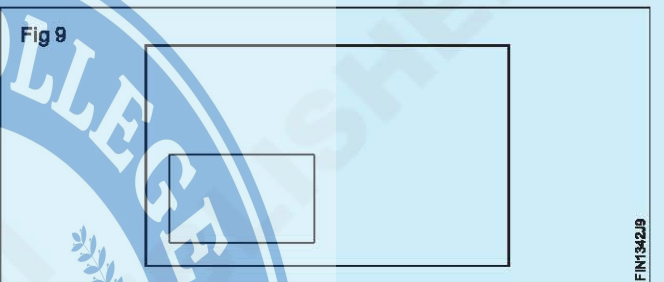
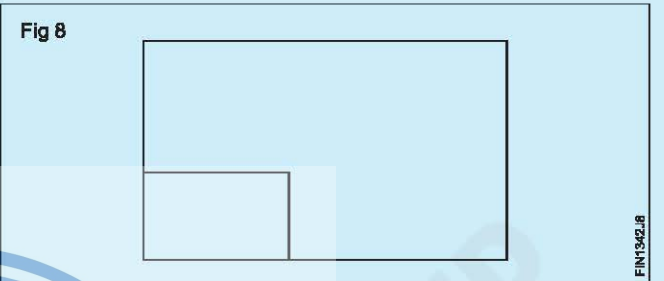

Marking with wing compass

Objectives : This shall help you to

- set the required dimension on a wing compass
- draw circles and arcs with a wing compass.

Wing compass

Verify that the legs of the compass are of the same length. (Fig 1)

If not, grind the leg and sharpen with an oilstone.

Punch at the intersection of the marked lines. (Fig 2)

Only a small dot is needed to prevent the compass from slipping.

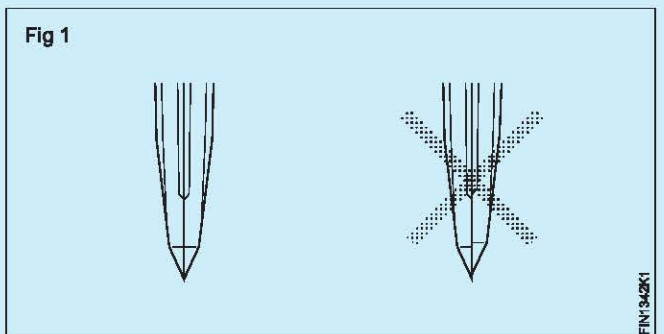

For small lengths, loosen the wing nut and open the compass wider and then squeeze with your right hand to adjust and match the required length on the rule. (Fig 3)

While adjusting the compass opening, use the middle of the rule and not the edge.

For larger lengths, place the rule on the worktable and adjust the compass opening, with both tips on the rule.

To close the legs fractionally, tap the outside of the leg lightly.

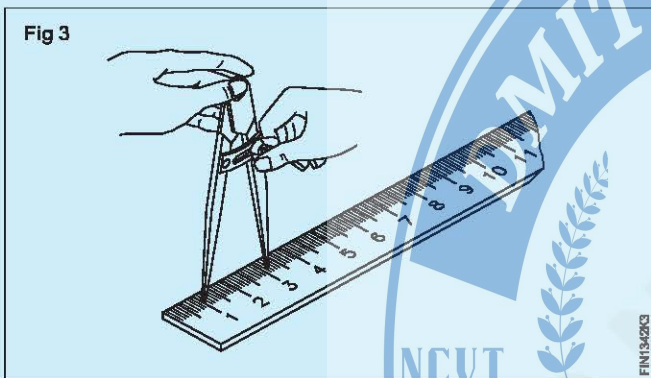
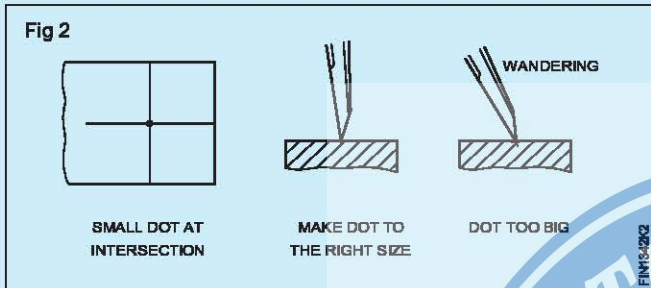

To open them fractionally, turn the compass upside down and tap the head lightly. (Fig 4)

After setting the dimensions, lock the legs with the wing nut and check the dimensions again.

Hold the compass head with the palm of your hand to prevent the compass point from slipping from the centre of the circle.

Do not press the wing nut.

Draw an upper half circle from the lower left to the right, using thumb pressure. (Fig 5)

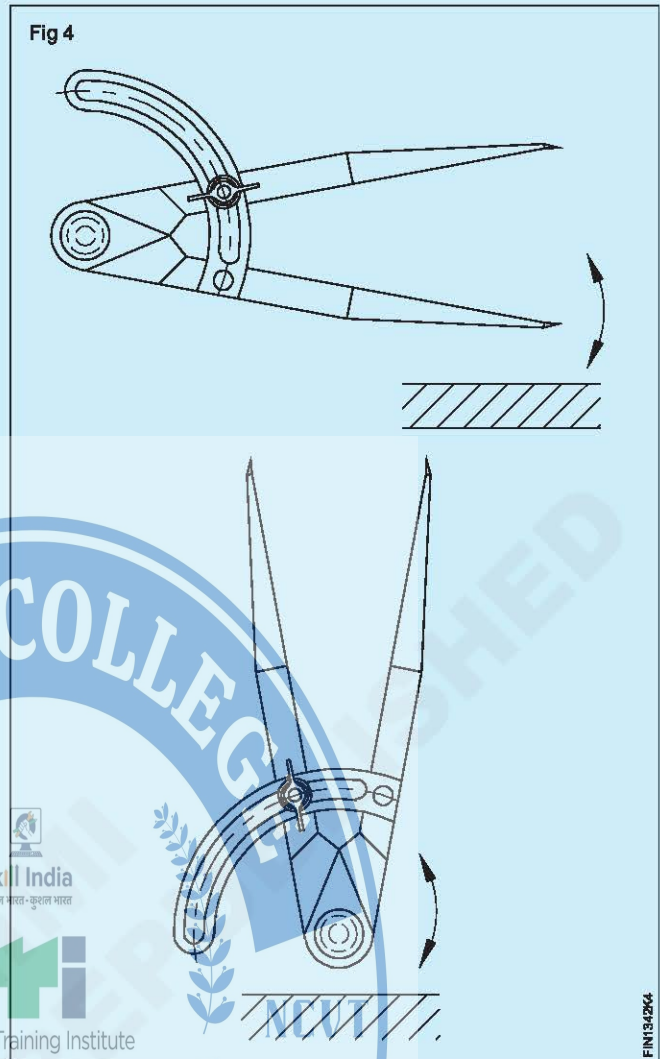
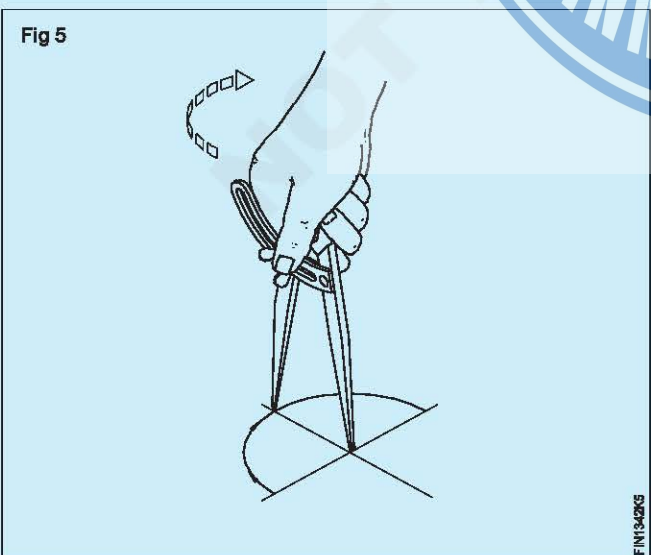

Change the thumb position on the compass, and draw the rest of the circle from the lower left. (Fig 6)

When drawing, tilt the compass slightly in the direction of rotation.

Draw clearly the first time itself.

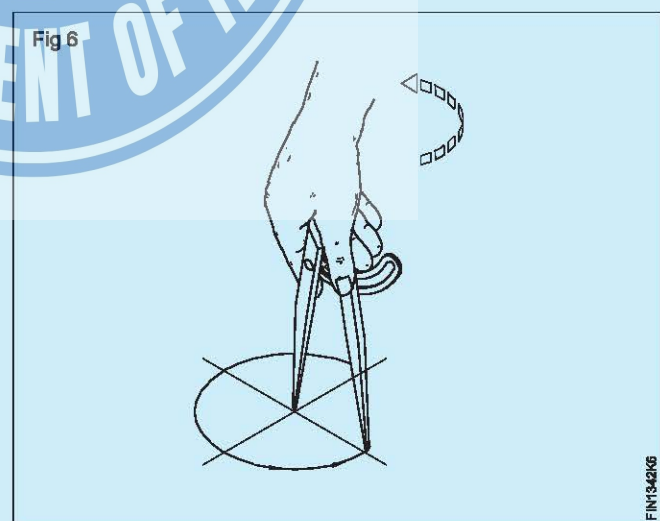

Mark curved lines

Objectives: This shall help you to

- mark the centre line using a scribe and a steel rule
- punch a dot mark using a dot punch
- mark curved lines using a wing compass.

Clean the tinman's stake and the sheet metal surface.

Flatten the sheet metal using a wooden mallet.

Check the size of the sheet metal using a steel rule.

Mark 'V' at the centre of the workpiece on opposite sides and join it using a steel rule and a scribe. (Fig 1)

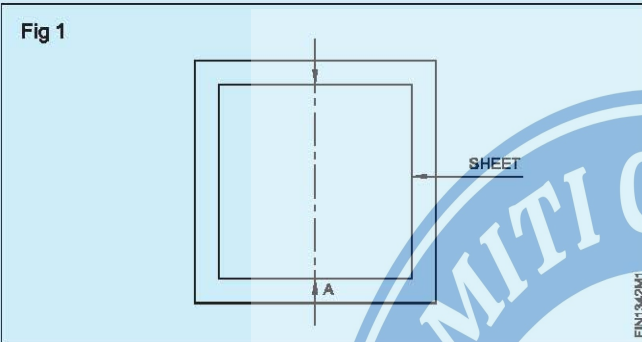

Mark the centre point on the centre line.

To punch the centre point use a dot punch. Place the sheet on the anvil stake. Hold the punch between the thumb and the first two fingers of the hand where possible, rest the little finger and the edge of your hand on the marked centre point as shown in Fig 2.

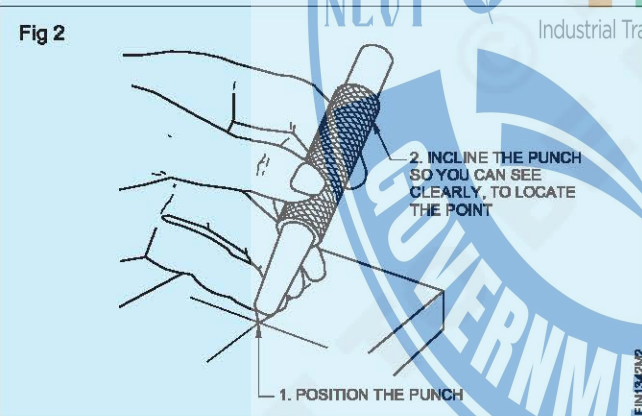

Bring up the dot punch in the vertical position and strike with a ball pein hammer on the head of the dot punch lightly.

Watch the point of the punch and strike its head with the ball pein hammer Fig3. This dot punch marks prevent the wing compass leg from slipping while scribing curved lines from the centre point.

Only a small dot is needed to prevent the wing compass from slipping. If the dot is too big, compass leg will wander as shown in Fig 4.

Now set the wing compass to the required dimension. Set one leg of the wing compass at the centre point, and scribe a curved line (arc) by rotating the wing compass as shown in Fig 5.

Safety: While striking the head of the dot punch, the hammer face must be free of burrs and oil substances. The hammer head must be held tight on to the handle by wedge.

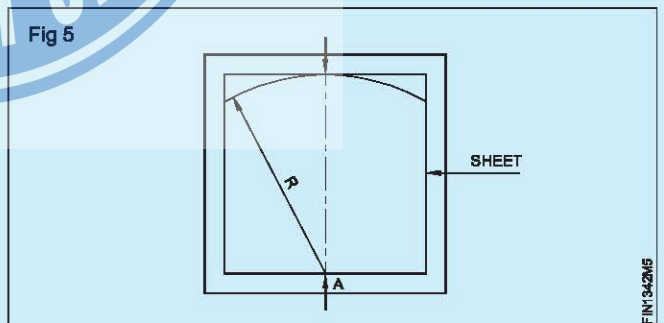
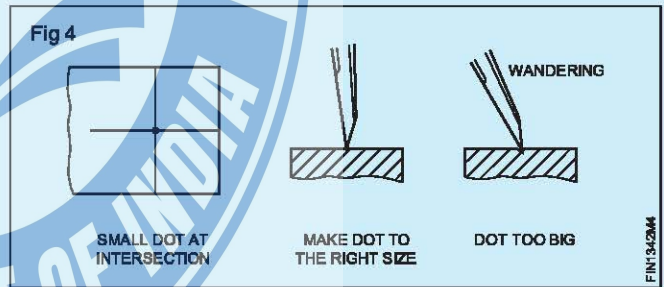
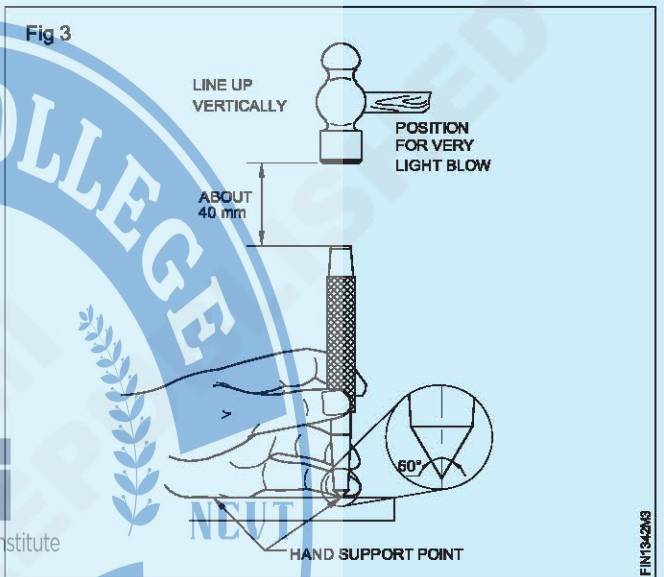

Cutting the sheet metal along straight line by straight snips

Objective: This shall help you to

- cut the sheet metal along a straight line by straight snips.

Hold the sheet in one hand and snip with the other hand, hold the snips handle at the end and place the upper blade of the snips on the line by keeping a smaller opening angle. (Fig.1)

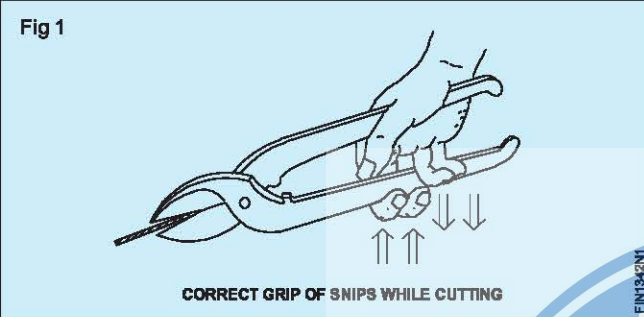

Grip the snips so that both the blades are engaged with each other without any clearance between the blades.

Maintain the gap in between the blades, to less than 20° (Fig 2 & 3)

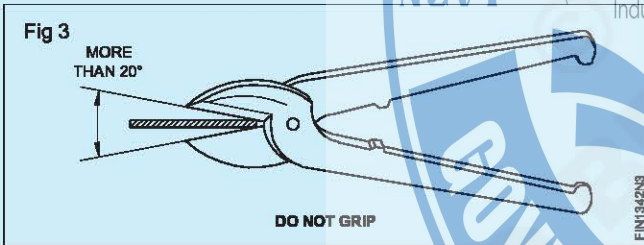
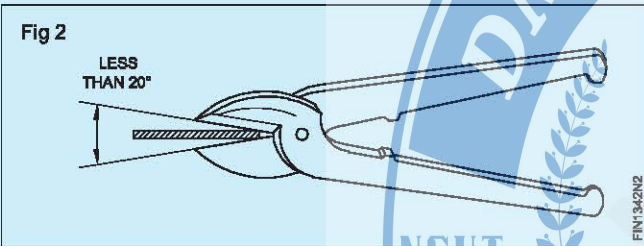

Keep the blade perpendicular to the surface of the sheet metal and hold the snips straight. (Fig 4)

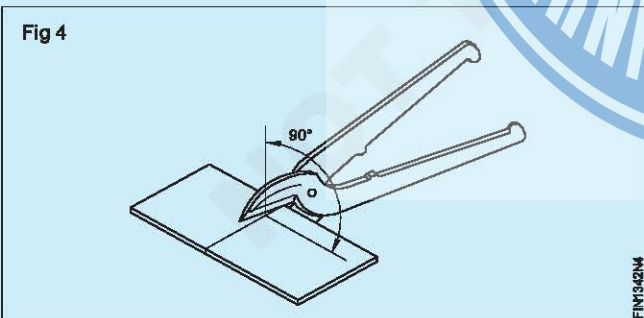

Do not use the full length of the blade for a single stroke.

If you use the full length of the blade for a single stroke, the cutting line will not be straight and also the blade corner will damage the sheet. (Fig 5)

As far as possible, keep a small part of the sheet on the left hand side at the time of cutting the sheet. (Fig 6)

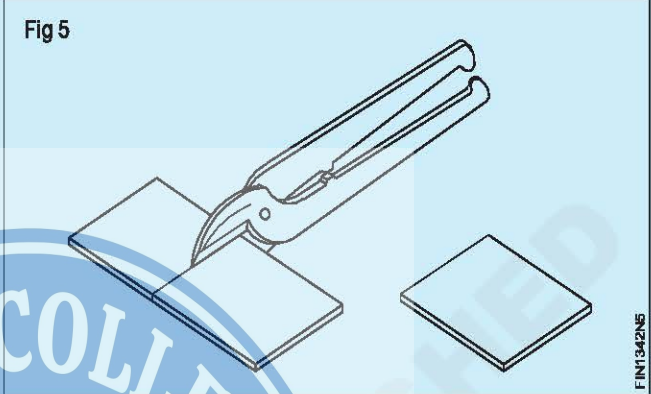

If stops are not provided in snips, care should be taken while cutting the sheet, not to pinch the palm of the hand between the bent ends of the snip handles while closing. (Fig.7)

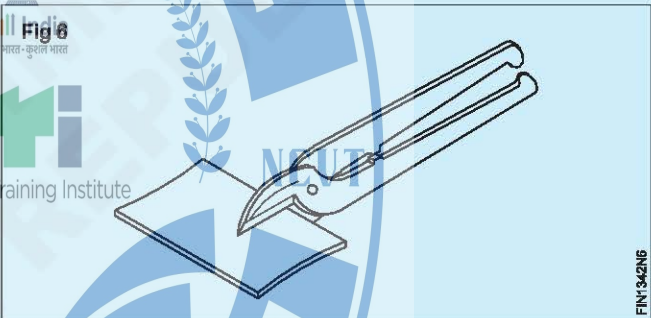

Cut the material along the scribed lines. (Fig.8)

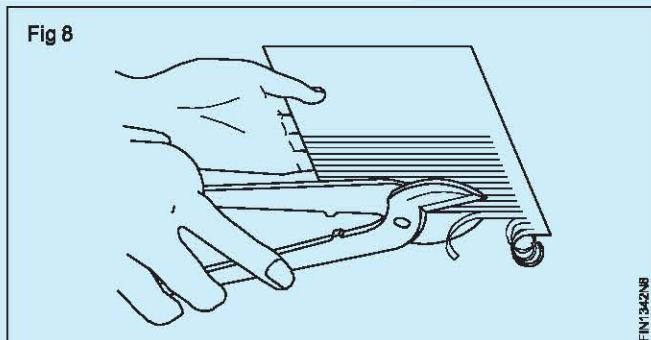
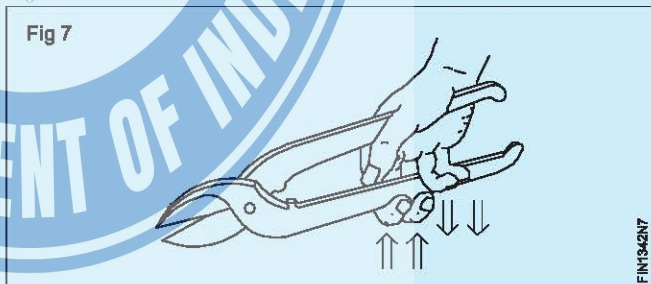

Cutting along curved lines

- Objectives:** This shall help you to
- cut outside curves on sheet metal by straight snips
 - cut inside curves on sheet metal by bend snips.

Cutting outside curves by straight snips

Hold the workpiece in one hand.
 Hold the straight snips by the other hand at the handle end.
 Keep the straight snips blade on the outside curved line at 90° angle and gently press the handle. This produces the shearing force which cuts the material. (Fig 1)

Accordingly, continue the process along the total length of the curved line, point by point, till the curved line ends.

Use small length of blade, while cutting outside curved lines to get correct curved shape.

Cutting inside curves by bend snips: The skill sequence is similar to that of cutting external curves except bend snips are used for cutting along internal curved lines. (Fig 2)

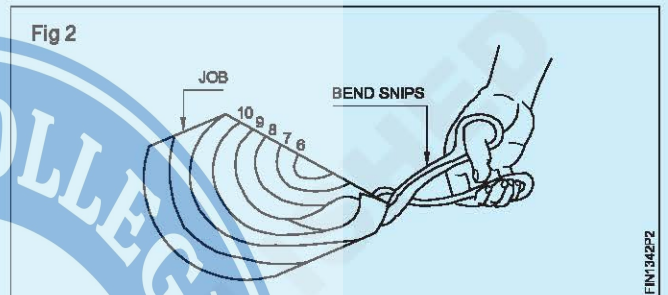
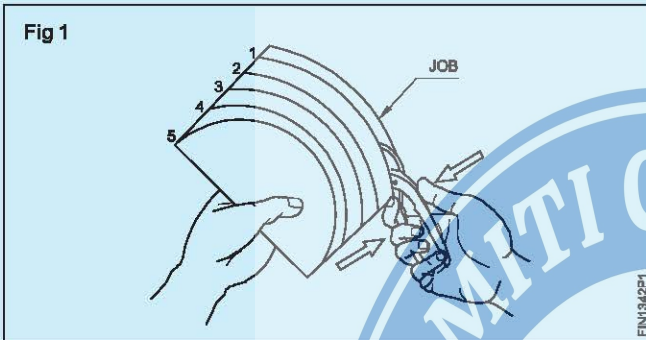

While cutting, move the snips forward along the curved line and the workpiece towards you. This motion should be synchronised to get a correct curved shape.

Sharpening of snips

- Objective:** This shall help you to
- sharpen the blunt snips.

Introduction: After continuous use, the cutting edge of the snips gets worn out and requires resharpening. (Fig.1)

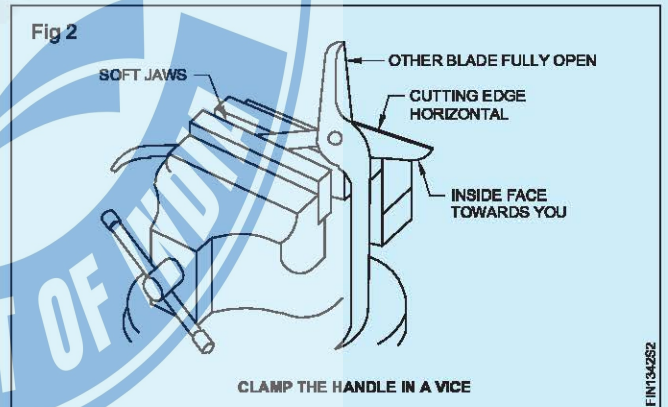
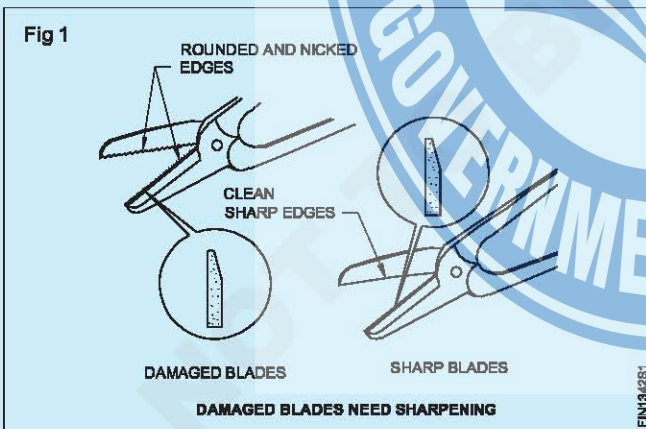

File the cutting face of the blade using a flat smooth file as shown in Fig 3.

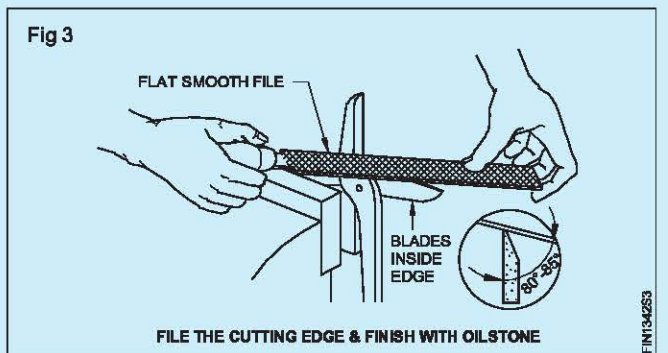

Ways of sharpening snips

- 1 Sharpening by files
- 2 Sharpening by oilstone
- 3 Sharpening by grinding wheel

Sharpening by files: Clamp the handle of the blade to be sharpened as shown in Fig 2.

Remove the snips from the vice, clamp the other handle in the vice as done before.

Sharpen the second blade by file.

Sharpening by oilstone: Clamp one handle of the snips in a bench vice.

Use the oil stone the same way as you use a file. (Fig 4)



Use the coarse side of the oil stone first. Use the fine side of the oil stone for finishing.

Remove the snips from the vice and repeat the same for the other blade.

Sharpening by grinding wheel

Switch on the off hand grinder.

Open the blades of the snips as far as possible.

Lay each blade to the grinding wheel as shown in Fig 5. Start grinding from the pivot joint and draw the blade across the grinding wheel. (Fig 6)

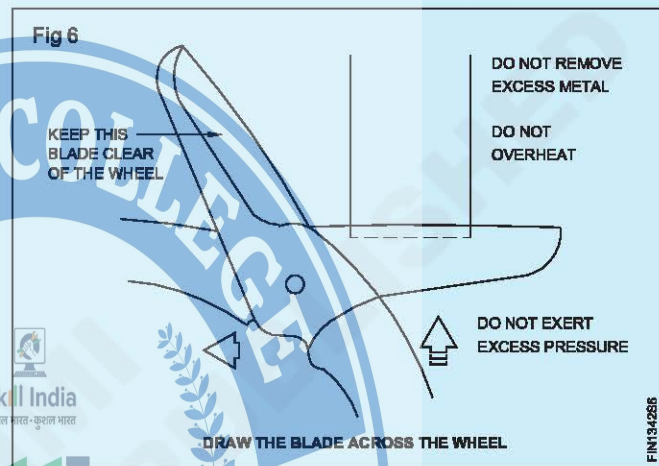
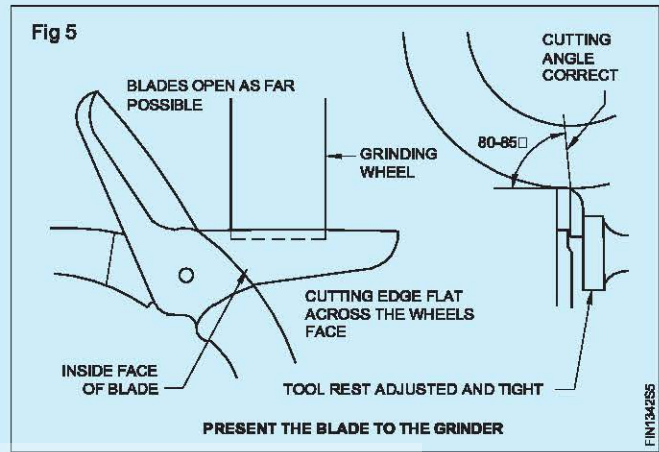

Marking triangle in a given circle

Objective : This shall help you to

- draw a triangle inside a given circle.

Draw the diameter BD of the circle. (Fig 1)

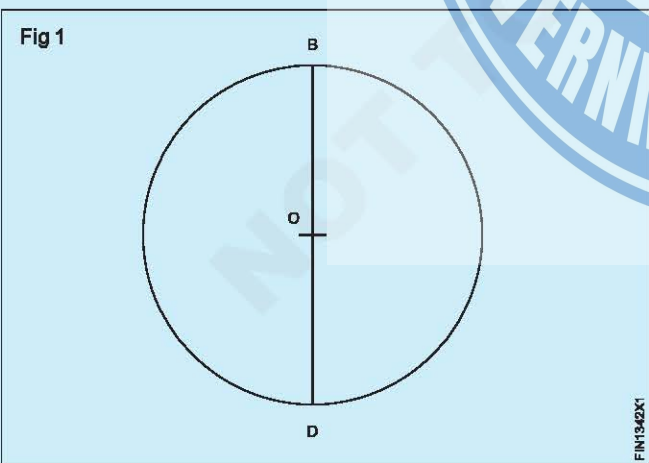

Draw an arc $d/2$ as radius and D as centre.

Let this arc intersect the circle at A and C. (Fig 2)

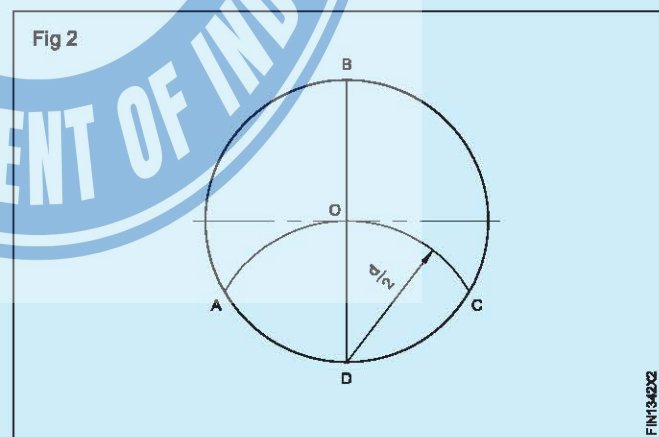

Join AB, BC, and AC to each other.

ABC is the triangle drawn inside the given circle. (Fig 3)

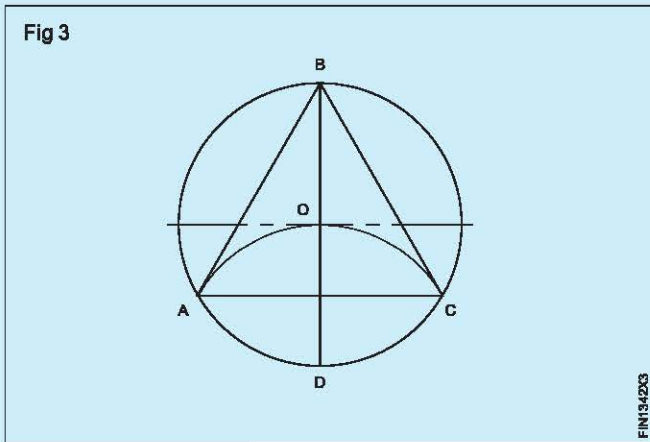

Marking square in a given circle

Objective : This shall help you to

- inscribe a square in a given circle.

Draw the diameter AC of the circle. (Fig 1)

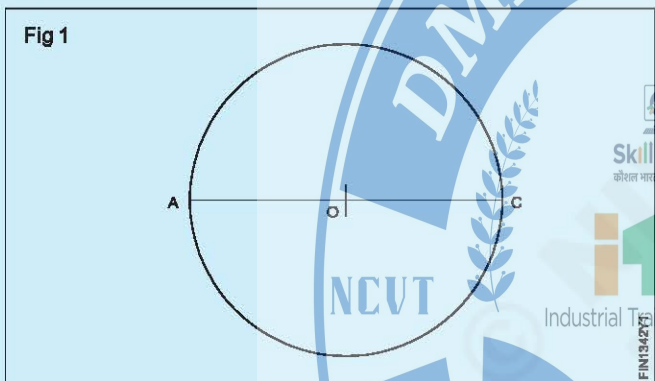

Draw two arcs 1 and 2 with A and C as centres on the top and bottom of the line BD. (Fig 3)

Let the arcs meet at B and D.

Join the points B and D

BD is the bisector of AC.

Join AB, BC, CD and DA to each other.

ABCD is the square drawn inside the given circle. (Fig 3)

Bisect AC. (Fig 2)

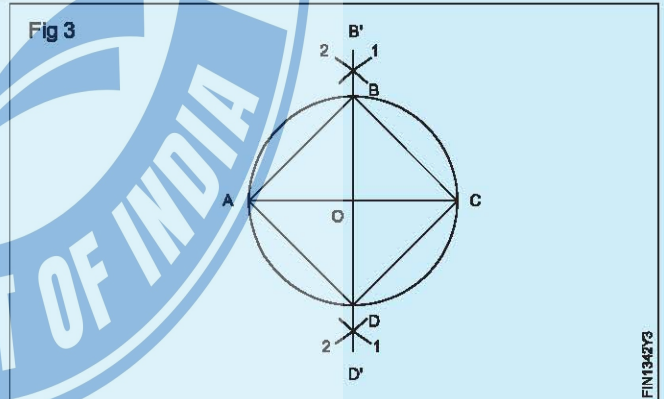
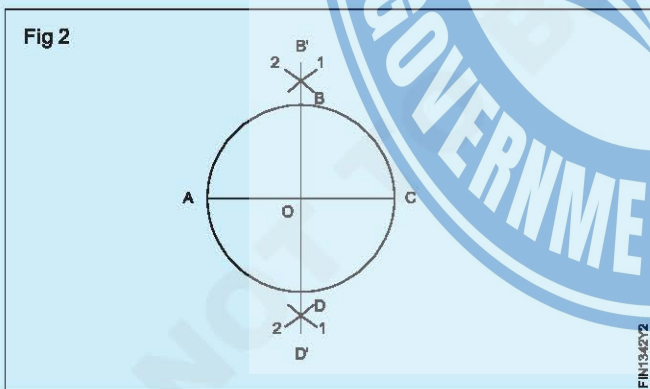

Marking a regular hexagon

Objective : This shall help you to

- inscribe a regular hexagon in a circle.

Inscribe a regular hexagon in a circle. (Fig 1)

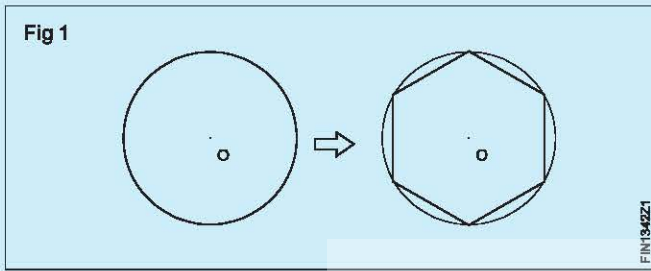

Draw the diameter vertically to the given circle whose centre is 'O'.

Let A and B be the intersecting points on the circumference. (Fig 2)

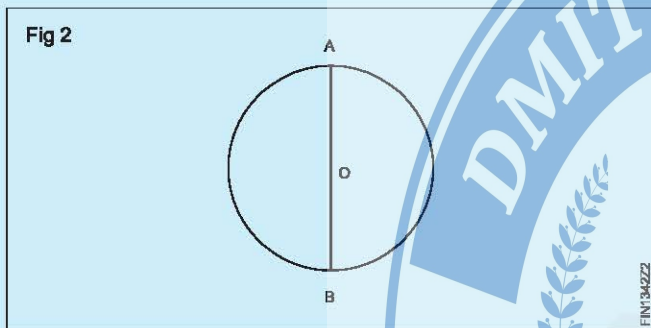

With AO as radius and A and B as centre, draw two arcs CD and EF respectively with the help of a compass. Let C, D, E, F be the intersecting points on the circumference. (Fig 3)

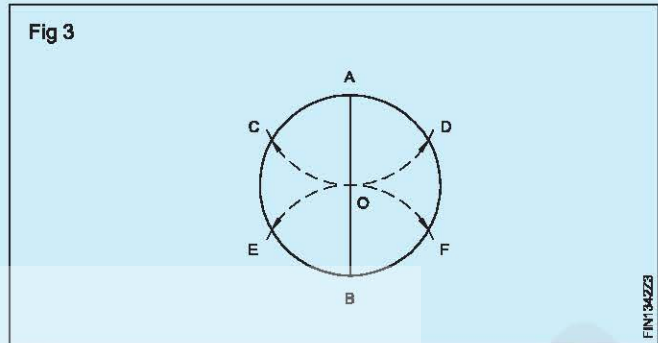

Connect points A, D, F, B, E and 'C' to each other. (Fig 4)

Now a regular hexagon is inscribed in the circle.

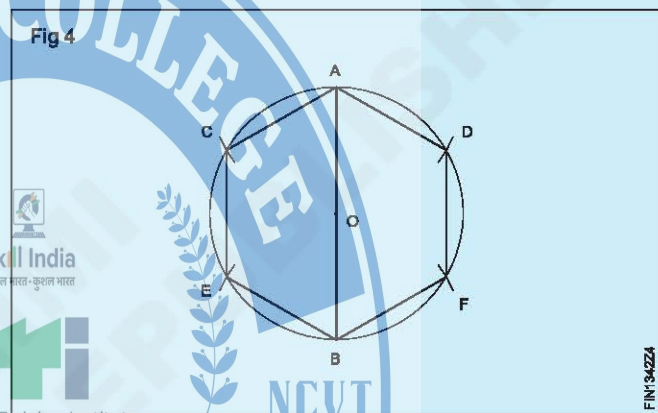

Marking out of simple development

Objectives: At the end of this exercise you shall be able to

- prepare development of cylinder in parallel line method
- prepare development of rectangular tray in parallel line method
- mark out the flaps for hemming.

TASK 1

HEMMING 5mm

LOCKED GROOVED JOINT 5mm

Ø100

124

A

B

NCVT

GOVERNMENT OF INDIA

Industrial Training Institute

1	ISSH 335 x 135 x 1.00	-	G.I. SHEET	-	-	1.3.43
NO.OFF	STOCK SIZE	SEMI-PRODUCT	MATERIAL	PROJECT NO.	PART NO.	EX. NO.
SCALE 1:2	PARALLEL LINE DEVELOPMENT OF CYLINDER				DEVIATIONS ±1mm	TIME
					CODE NO. F120N1343E1	

TASK 2

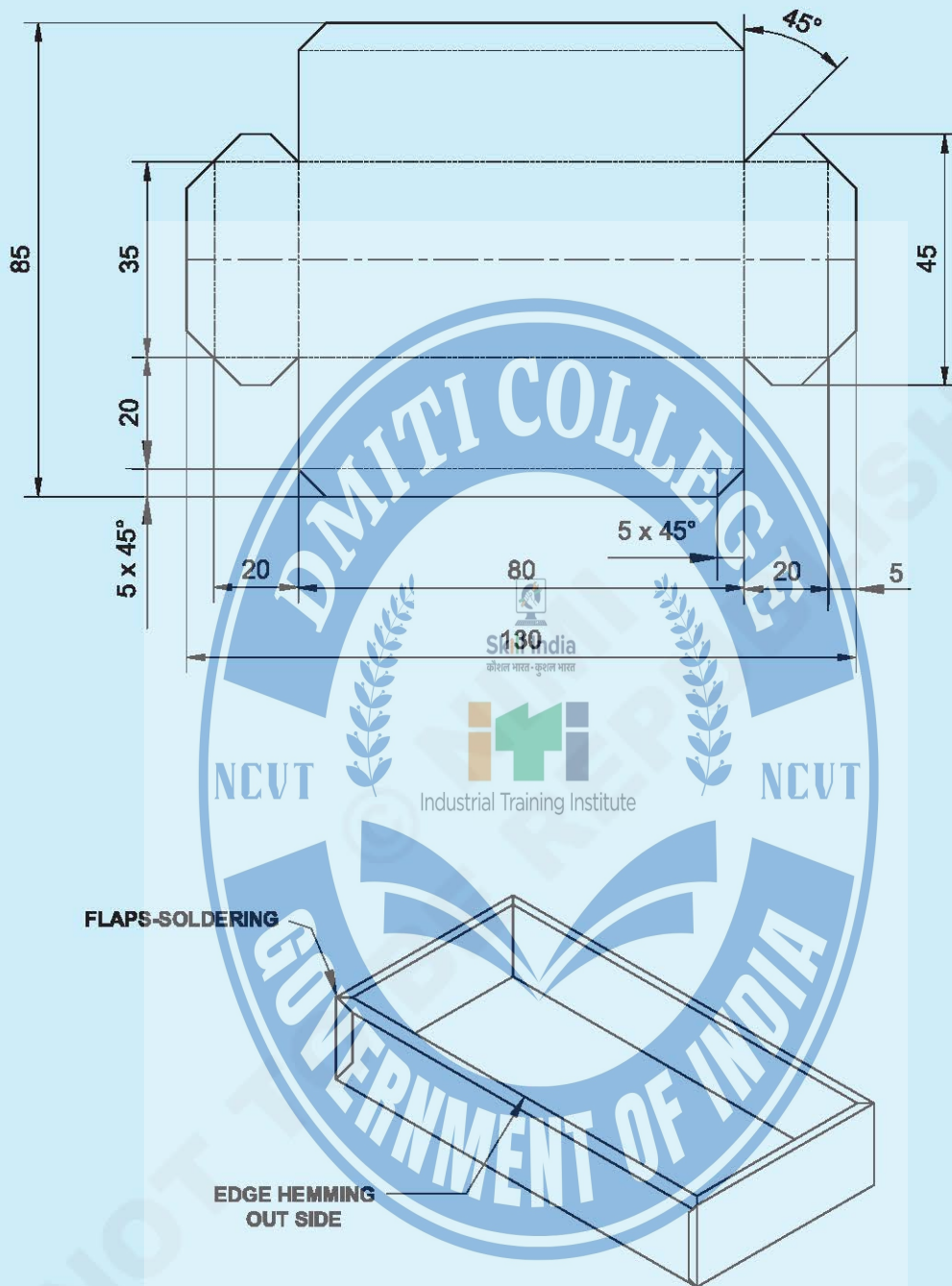

1	ISSH 135 x 90 x 1.0mm	-	G.I.SHEET	-	-	1.3.43
NO.OFF	STOCK SIZE	SEMI-PRODUCT	MATERIAL	PROJECT NO.	PART NO.	EX. NO.
SCALE 1:8	PARALLEL LINE DEVELOPMENT OF RECTANGULAR TRAY				DEVIATIONS ±1mm	TIME:
					CODE NO. FI20N1343E2	

Job Sequence

TASK 1: Parallel line development of cylinder

Develop and layout the pattern for the cylinder with all allowance for joining and hemming on drawing sheet by parallel line method.

Draw the elevation and plan of the object as per the given dimensions on drawing sheet (A3)

Divide the periphery of the circle into 12 equal parts. (Fig.1)

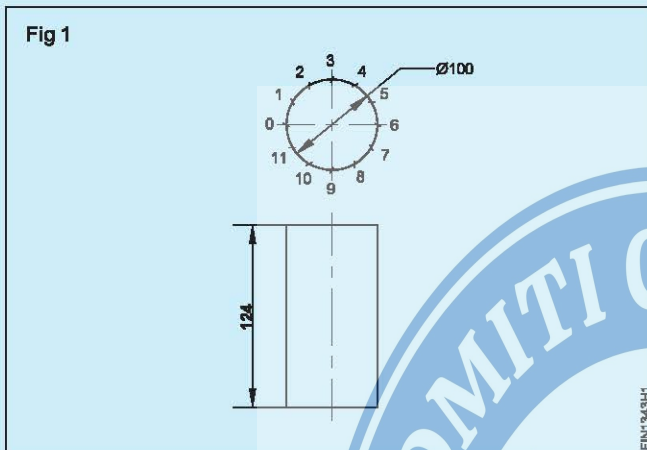

Extend the line from the base to the maximum length, i.e. more than the circumference of the cylinder. (Fig.2)

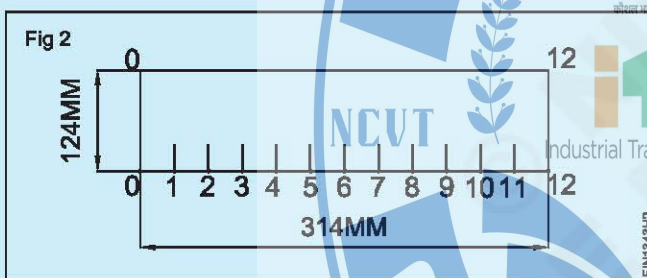

Draw line parallel to base line to the height of 124mm (Height of cylinder) and draw perpendicular line at the end of 314mm base line.

Transfer the distance from 0 to 1, using a compass on the base line as per shown in Fig.2 and continue to mark 1 to 2, 2 to 3 upto 11 to 12.

TASK 2: Parallel line development of rectangular tray

Calculate developed length and width of a rectangular box.

Developed length=Base length +2(side height+single hemming allowance)

$$=80+2(20+5)=130\text{mm}$$

Developed width=Base width + 2(side height+single hemming allowance)

$$=35+2(20+5)=85\text{mm}$$

Mark and cut the sheet metal work piece to the size of 130x85mm maintain squareness.

Draw the centre lines of the length and width XX and YY. (Fig.1)

Draw perpendicular lines from base line through points. 0, 1, 2, 3, 4, 5, 6, 7, 8, 9, 10, 11 and 12 are already drawn base line (Fig.3)

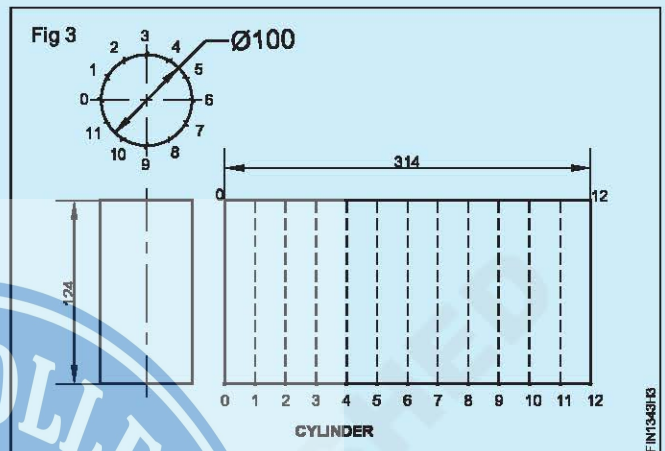

Mark the lines at 4mm distance on the top and bottom of the pattern for hemming at the top edge and joining at the bottom edges. (Fig.4)

Draw the lines parallel to '00' and 12 12' at a distance of 5mm and 10mm on both sides respectively for seaming. Complete the development of cylinder as per the given dimension.

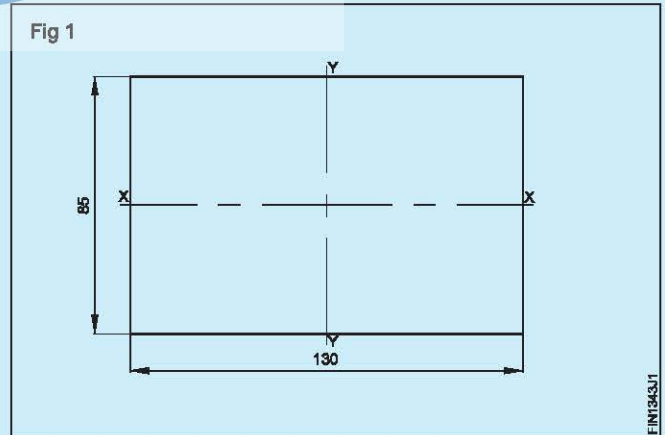
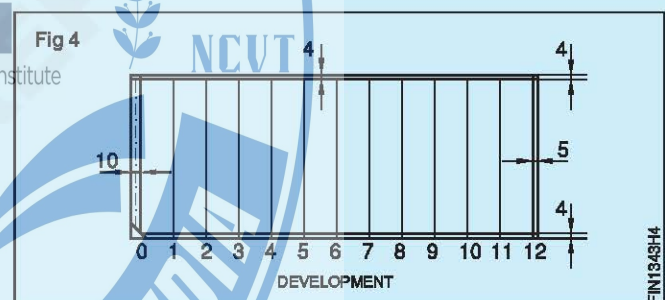

Draw the base length and width at the centre of the work piece from centre line. Mark lines at 40mm on both sides of YY and 17.5mm on both sides of XX (Fig.2)

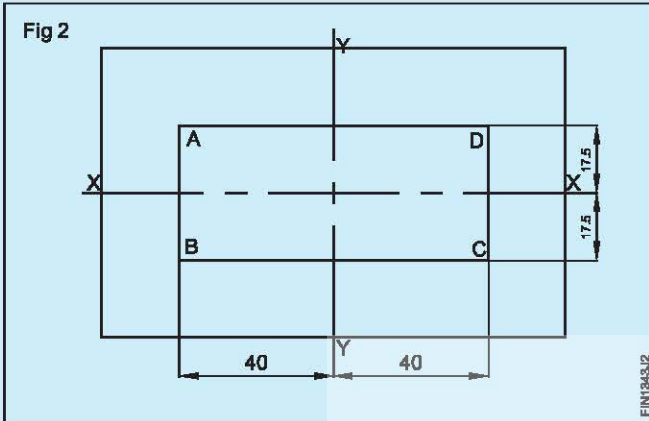

Draw lines for 20mm height of the four sides of the rectangular box parallel to AB, BC, CD and DA as shown in the fig.3.

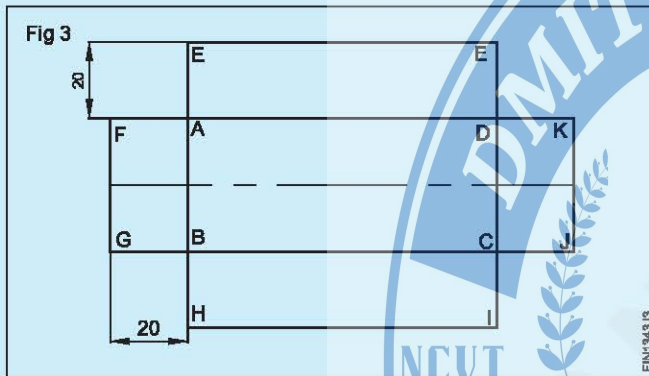

Draw lines for 5mm single hemming allowance on the four sides parallel to FG, HI, JK and LE as shown in Fig.4.

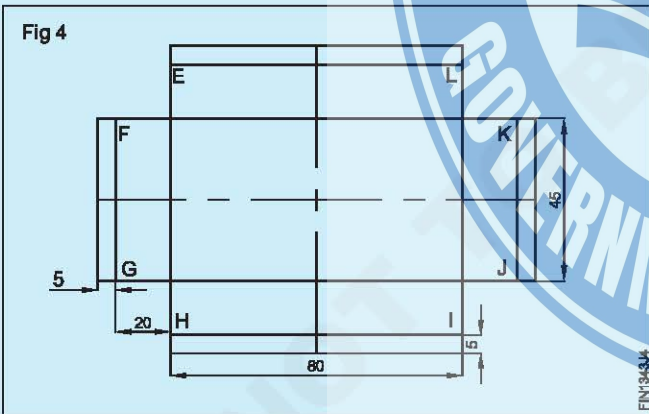

Draw lines on 20mm lap for the solder joint at the corners of the rectangular box parallel to GB, AF, CJ and DK as shown in fig.5.

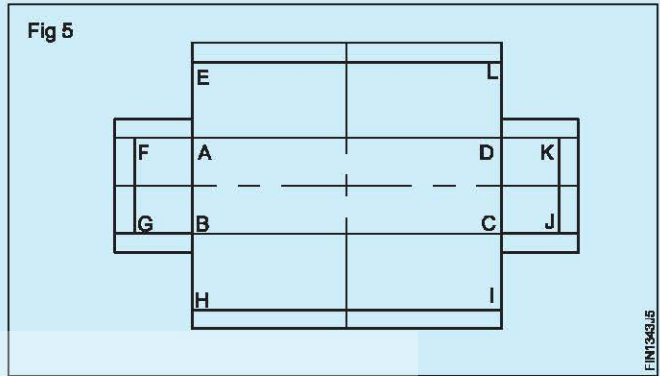

Draw lines for 45° slant notches at points H, I, J, K, L, E, F, G, A, B, C and D as shown in the fig.6.

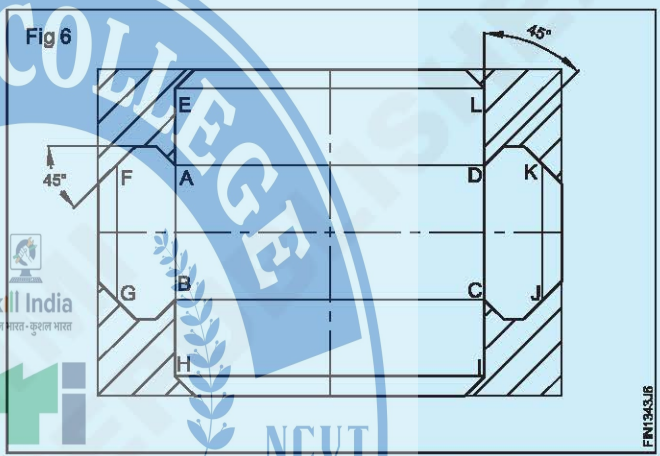

Complete the development of rectangular tray as per the given dimension.

Skill Sequence

Parallel line development of a cylinder

Objective: This shall help you to

- develop and layout a pattern for a cylinder by parallel line development method.

Draw the front elevation and the plan of the cylinder on a paper. (Fig 1)

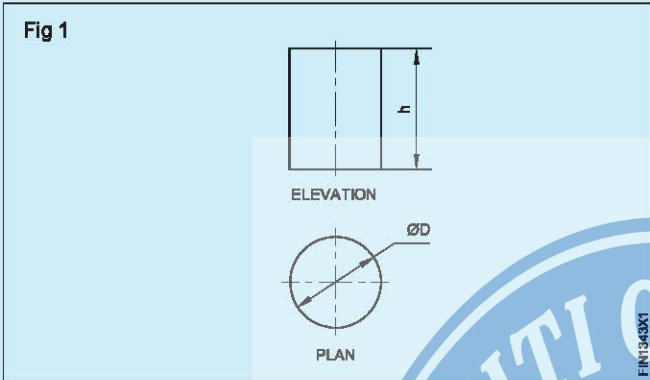

Transfer equal distances 0,1,2,3,4 upto 12 of the plan on the circumferential line without disturbing the equal lengths with compass. (Fig 5)

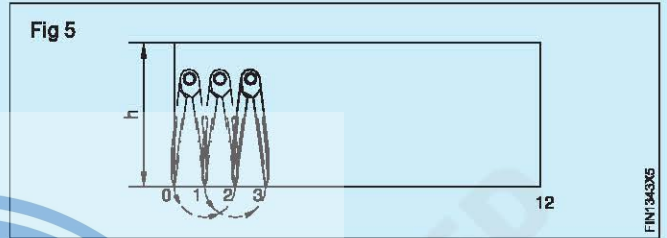

Divide the periphery of the circle into 12 equal parts and check each division. (Fig 2)

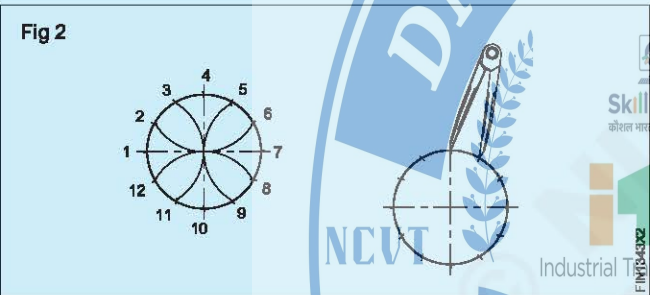

Draw a perpendicular at the end of the twelfth point of layout to the base line. (Fig 6)

Draw parallel lines to line 00' at points 1,2,3,4 upto 12. (Fig 6)

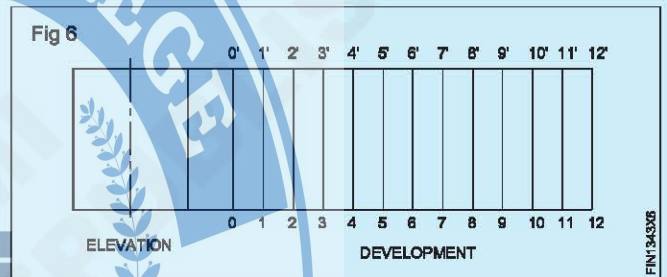

Extend the lines to a length slightly more than the circumference of the circle (pd) plus the allowances for the locked grooved joint. (Fig 3)

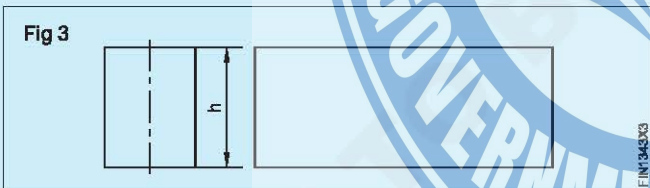

Mark the lines at 4 mm distance on the top and bottom of the pattern for hemming at the top edge and joining at the bottom edge. (Fig.7)

Draw the lines parallel to 00' and 12 12' at a distance of 5mm and 10mm on both sides respectively for seaming. (Fig.7)
Now the pattern is completed.

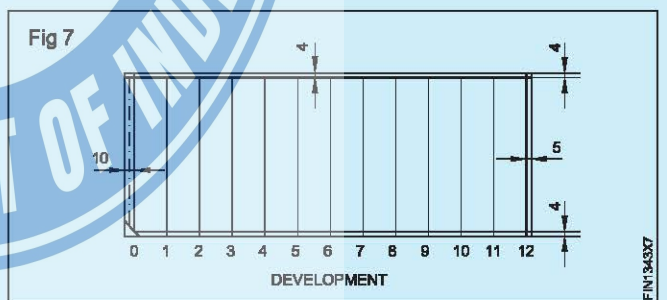

Draw a line 00' perpendicular to the parallel line through the left end. (Fig 4)

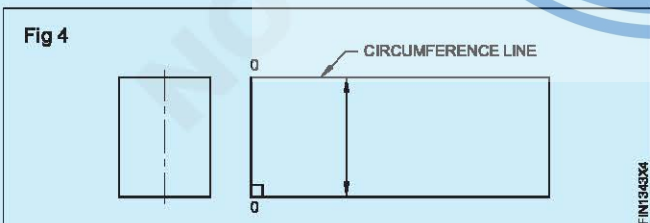

Marking out for flaps for soldering and sweating

Objectives: At the end of this exercise you shall be able to

- make rectangular tray as per given dimensions
- develop the pattern by parallel line method
- cut as per the required dimensions and make the rectangular tray
- solder and sweat soldering.

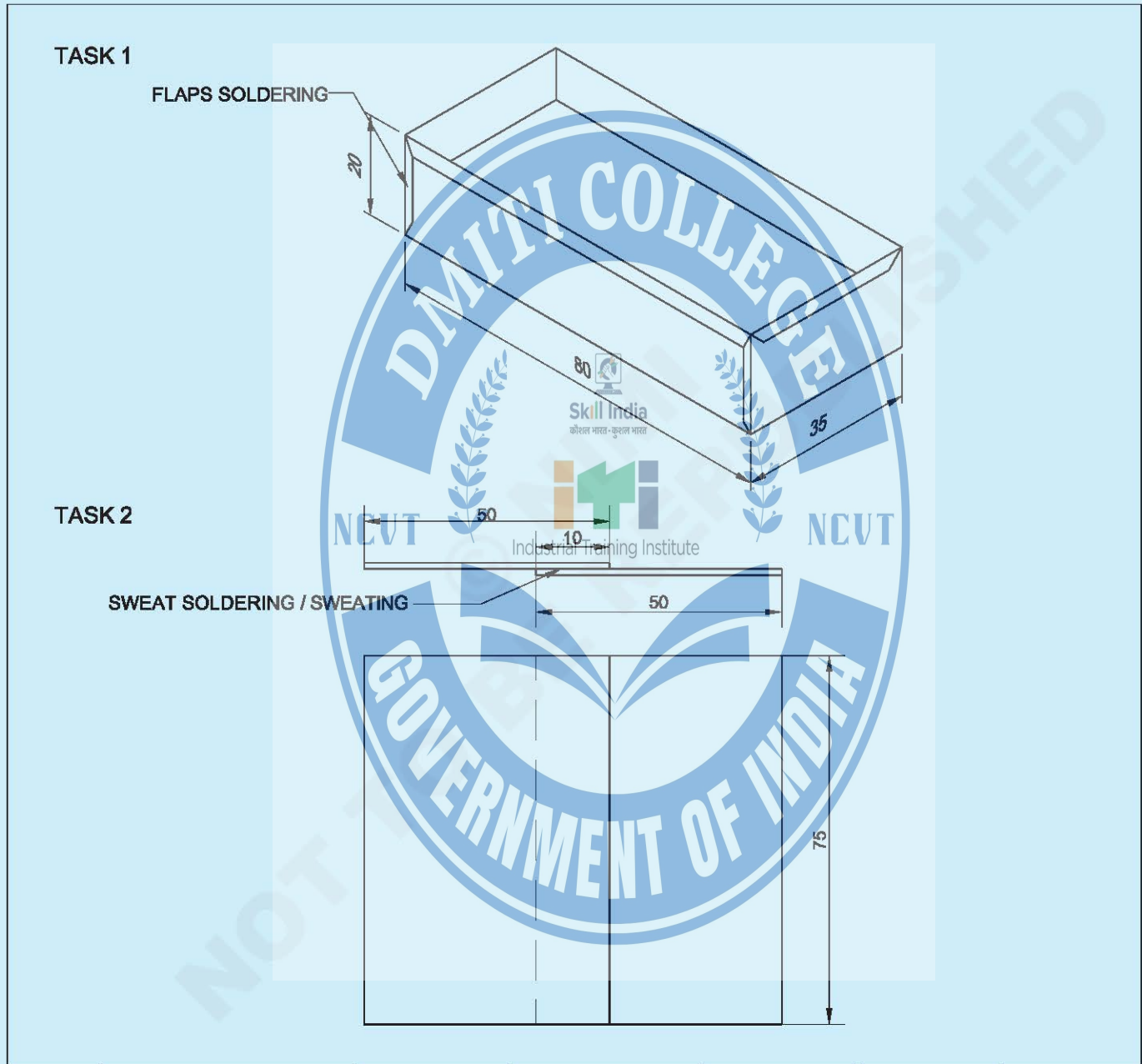

2	ISSH 75 x 50 x 1mm	-	G.I SHEET	-	TASK 2	
-	-	1.3.43	-	-	TASK 1	1.3.44
NO.OFF	STOCK SIZE	SEMI-PRODUCT	MATERIAL	PROJECT NO.	PART NO.	EX NO.
SCALE 1:1	<p align="center">MAKING RECTANGULAR TRAY AND FLAPS SOLDRING</p>				DEVIATIONS ±0.4	TIME
					CODE NO. F120N1344E1	

Job Sequence

TASK 1: Making rectangular tray and flaps soldering

Check the size of sheet as per sketch using a steel rule.

Level the sheet on the leveling plate using a mallet.

Develop the tray by the parallel line method.

Cut the unwanted area shown in shadow using a straight snip (Fig.1)

Cut the notches at 45° using a straight snips (Fig.1)

Deburr the edges of the sheet metal pattern using a smooth flat file.

Form a single hemming on four sides of the tray.

Bend the four sides to 90° using a Tinman's anvil.

Bend all the flaps to 90°. (Fig.2)

Join the four corners by soft soldering.

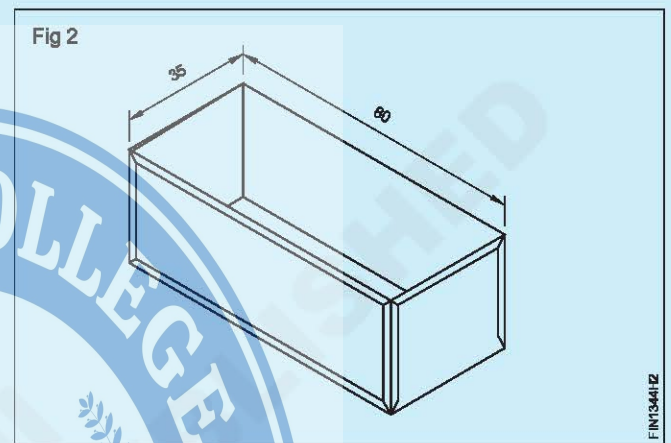
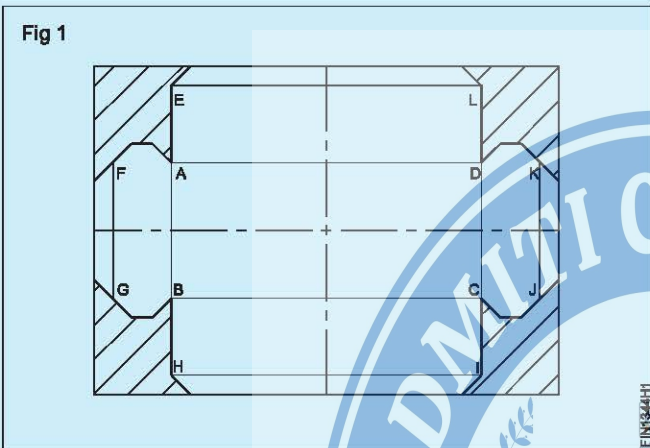

TASK 2: Soldering and sweating

Cut two pieces to the size 75 x 50 mm.

Flatten the sheets on Tinman's anvil.

Clean the surfaces to be joined thoroughly with abrasive cloth and a dry cloth.

Apply flux on surface of the sheets.

Place the surfaces to be joined in correct alignment as shown in Fig 3.

Heat the soldering iron bit in forge or blow lamp, hot enough to melt the solder.

Dip the point of the soldering bit into a dipping solution to avoid oxidation.

Apply solder to the bit.

Place the bit in correct position, over the lap opening at one end of the joint.

Lift the bit from the joint to get a smooth tack of solder.

Similarly tack at regular intervals along the joint.

Tacking provides temporary holding of the sheets.

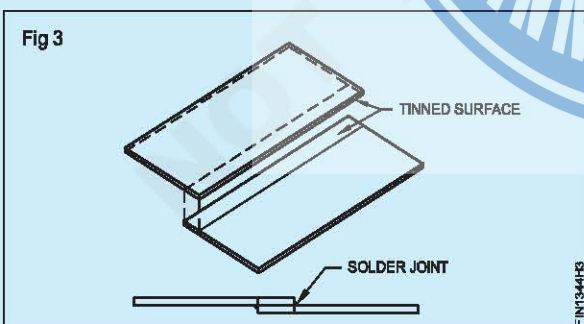

Move the bit steadily along the joint in one direction.

Continue the soldering until the joint is completed.

Similarly, solder other side of the lap joint following above procedures.

Allow the joint to cool.

Wash off all traces of flux with running water.

Clean the job with rag.

Skill Sequence

Preparing the soft solders

Objective: This shall help you to

- prepare soft solder in varying proportion in the form of stock to suit the metal to be joined.

In soft soldering process, soft solder is required to be prepared in the required proportion of tin and lead, when tin and lead are supplied in pure form.

They are generally prepared in the form of triangular sticks.

First measure required quantities of tin and lead in kilograms. For example to prepare 60/40 soft solder, take 600 gms of tin and 400 gms of lead to prepare 1 kg of soft solder.

Melt the lead first in a crucible, cast iron pan or ladle. (Fig.1) Lead is melted first because its melting temperature is higher than tin. (327°C)

Add little amount of sulphur to the mixture as flux and clean the alloy. (5 gm of sulphur/kg of solder)

Restir the mixture and increase the temperature until the alloy is free flowing.

Sulphur unites with impurities which rise to the surface, burns and forms a dross.

Remove the dross with a perforated ladle. (Fig 2)

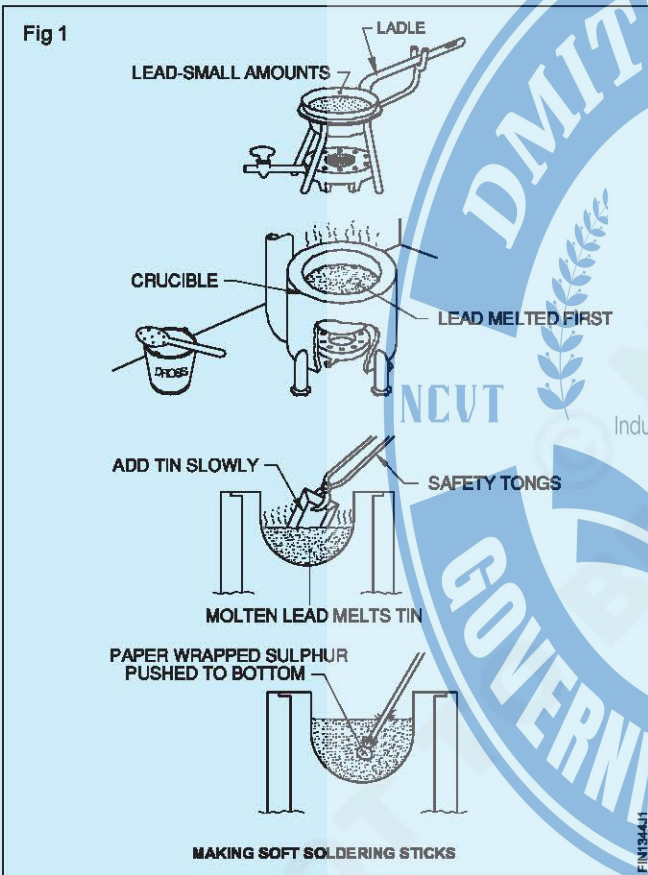

Add tin slowly to the molten lead and blend by stirring the mixture. (Fig 1)

Reduce the temperature of solder until the mixture will not flow readily.



Use angle iron as a mould.

Clean the angle iron and pour the molten solder carefully and continuously as shown in Fig 3.

WARNING

Molten solder will splatter violently in contact with moisture. The moulds must be preheated.

Allow the solder to set.

Remove the stick after getting cooled.

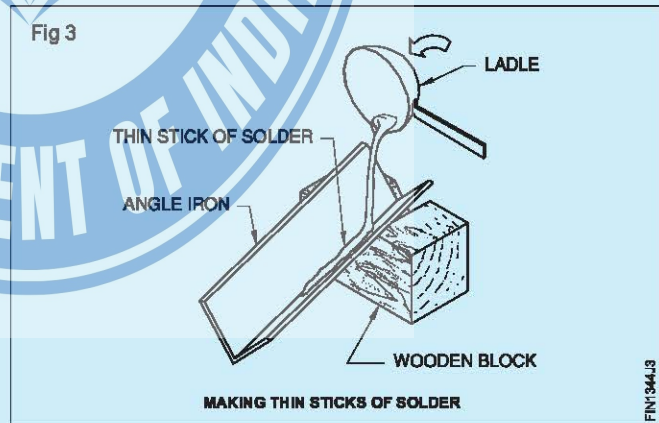

Preparing the working point of soldering bit

Objective: This shall help you to

- tin a soldering bit for free and uniform flow of solder on to the workpiece without oxidation.

In case of a new bit, hold the bit in a vice and file the burrs from the face and edges and lightly round off the point with a file.

In case of a bit in use, clean the bit point with a file, remove the pitted faces and rough edges. (Fig. 1)

If the soldering bit is too hard to file, heat it till it melts the solder freely and then cool it by dipping into cold water.

Heat the bit until colours appear on the faces, Don't over heat the bit.

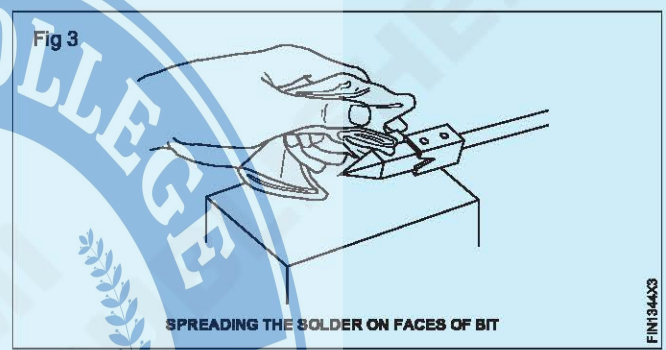
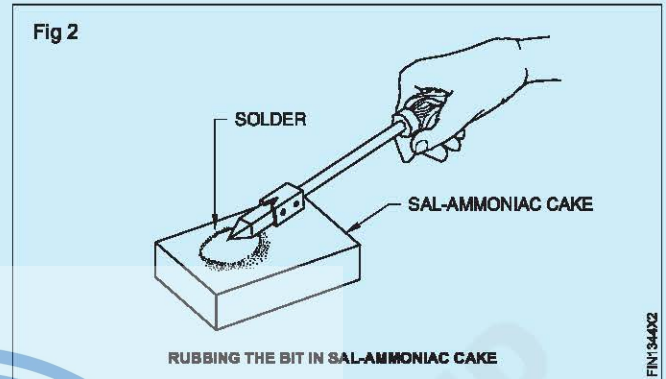
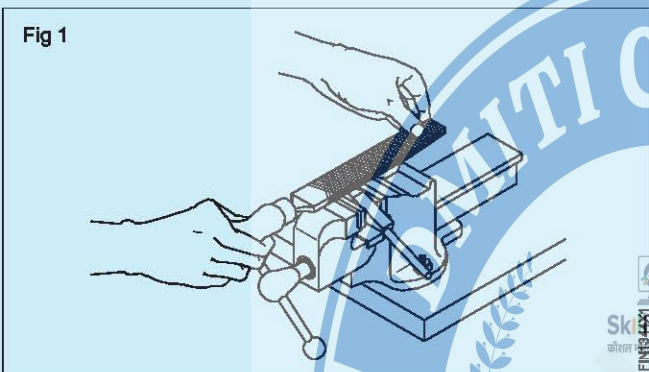

Rub all faces on sal-ammoniac cake. (Fig 2)

Apply stick solder to each working face, as it is rubbed on the sal-ammoniac cake.

Spread the solder uniformly over the faces and remove the excess solder by wiping with a piece of rag. (Fig 3)

Now a thin bright film called "tin" is formed on the faces of the copper bit. This is called tinning.

Avoid breathing fumes from the sal-ammoniac which causes headache and is injurious to the lungs.

Tacking and soldering the joint

Objective: This shall help you to

- set and tack the lap joint in correct alignment
- solder a lap joint with uniform flow of solder, in flat position
- inspect a lap joint, to ensure strong joint.

Check the size of the material using steel rule and try-square. Select a suitable type of soldering bit. (Copper)

Tin the soldering bit. Select the suitable flux for the job.

Select the suitable solder for the job.

Clean the surface to be joined with an abrasive cloth and then with a dry cloth, making it free from dirt, rust, oil, grease etc. (Fig 1)

Apply flux to the joint as shown in Fig.2.

Place the surfaces to be joined in correct alignment.

Heat the bit in forge or blow lamp, hot enough to melt the solder readily. The effect of heating the bit is shown in Fig 3.

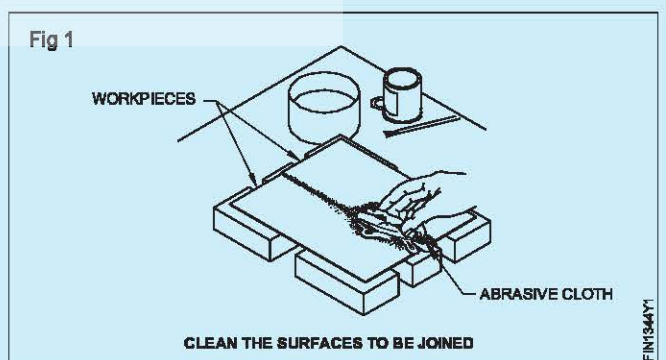

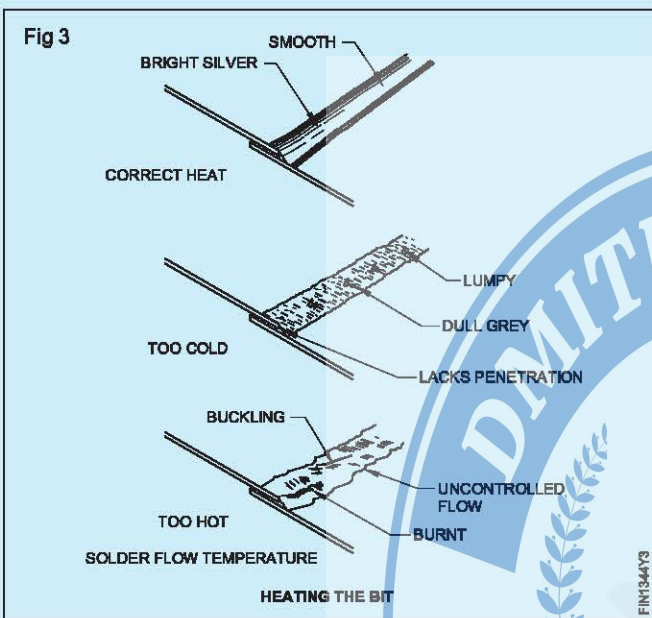
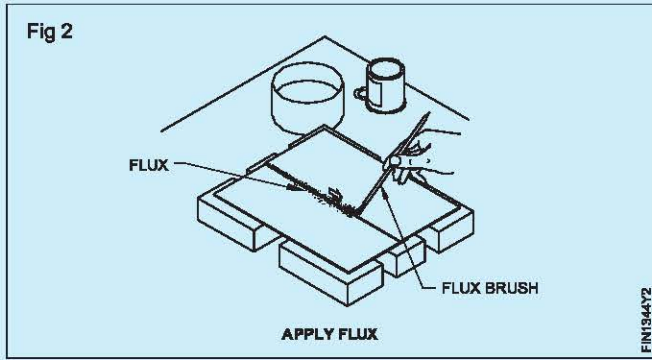

Do not allow it to become red hot otherwise tinning gets burnt off or it will form a bronze coating over the tip, on which solder will not stick properly.

Dip the point of the bit into a dipping solution to avoid oxidation. (Fig 4)

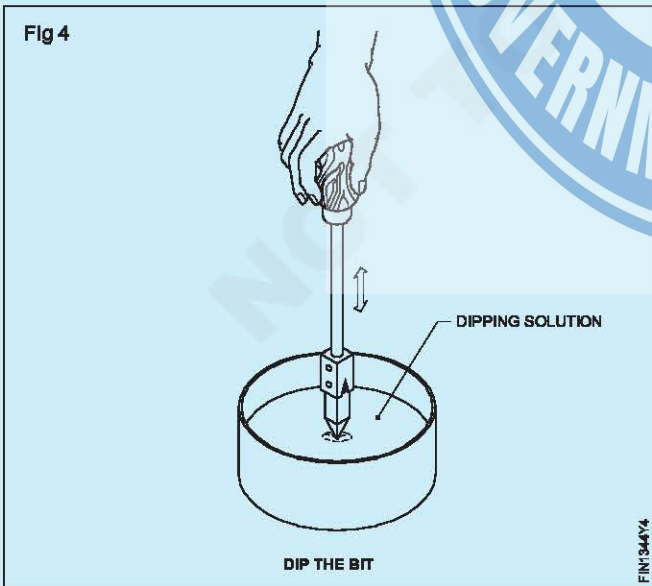

Apply solder to the bit.

Place the bit in correct position, over the lap opening at one end of the joint. (Fig 5) Hold the bit steady till the solder flows onto the workpiece and covers the lap opening. (Fig.5)

Lift the bit from the joint to get a smooth tack of solder. (Fig 5)

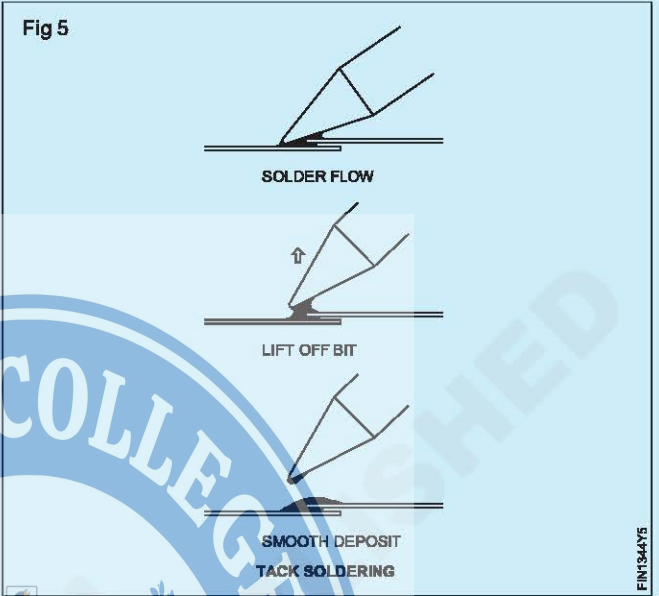

Similarly, tack at regular intervals along the joint. Tacking provides temporary holding of the sheets. (Fig 6)

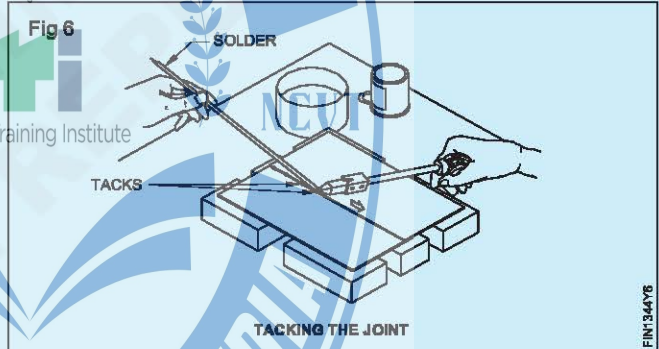

Re-heat the bit, if necessary. Place the bit on one end of the seam, add solder to the bit and allow the solder to melt and flow into the joint, which takes place by capillary action.

While soldering, to prevent the lap joint from springing apart, the joint is held in place by a stick of wood.

Move the bit steadily along the joint with a consistent movement, in one direction. (Fig 7)

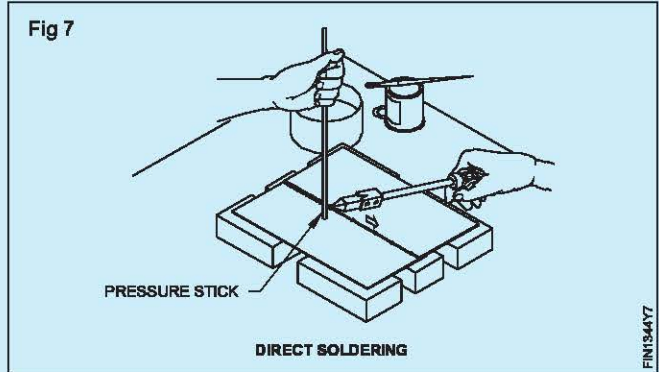

Add solder as required.

Continue the soldering until the joint is completed.

The joint will not be satisfactory if the solder is just 'struck on' or 'melted on'. Solder should flow freely. Allow the joint to cool.

Wash off all traces of flux with running water and clean the job with rag. (Fig 8)



Inspect the lap joint for the penetration of the solder into the lapped surfaces.

Ensure that the opening is sealed with a neat, smooth fillet of solder.

Upper surfaces of the seam should show a smooth, thin coatings of solder, uniform in width with tidy solder margins.

Never file the soldered joint.

Sweating or sweat soldering

Objective: This shall help you to

- sweat solder a lap joint, using a blow lamp.

Cut the sheet or pieces to the required size and mark.

Clean the surfaces to be joined thoroughly free of dust, dirt and oily surface.

Coat the surface to be joined with flux. (Fig 1)

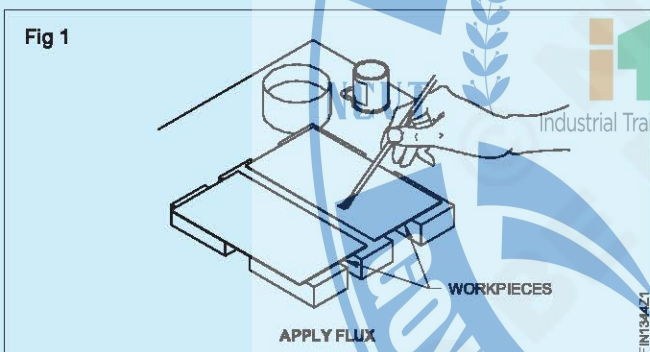

Apply an uniform coating of solder to each of the surface to be joined. (Fig 2)

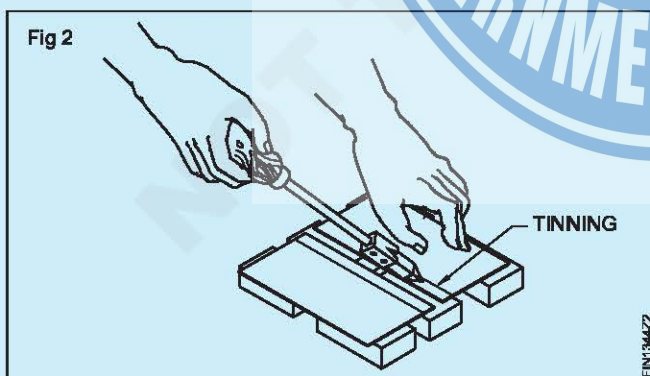

Place and align the tinned surfaces one on the top of the other.

Ensure that the tinned surfaces are in contact.

Place the flat side of the heated copper bit on one end of the joint.

Press down the joint with a rod, as the solder in between the two surfaces begins to melt and flow. (Fig 3)

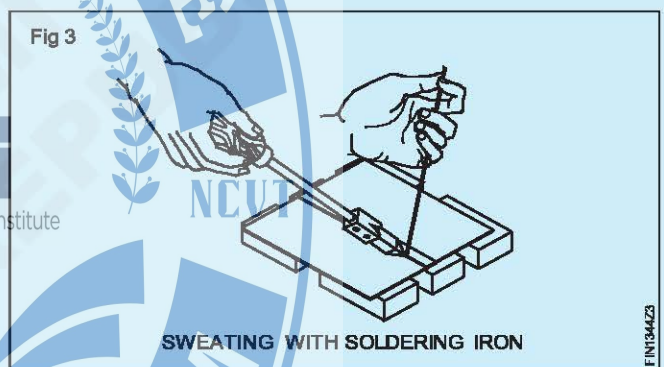

Draw the bit copper slowly along the joint and follow with the hold down piece.

While moving the copper bit forward, ensure that the solder melts. Otherwise, the joint will not be proper.

Constant supply of heat will produce a successful sweat soldered joint.

Hence, it is advisable to use two copper bits for this operation whereby, when one is in use, the other can be heated and kept ready for continuous operation.

Sweat soldering can also be done using a blow pipe as shown in Fig 4.

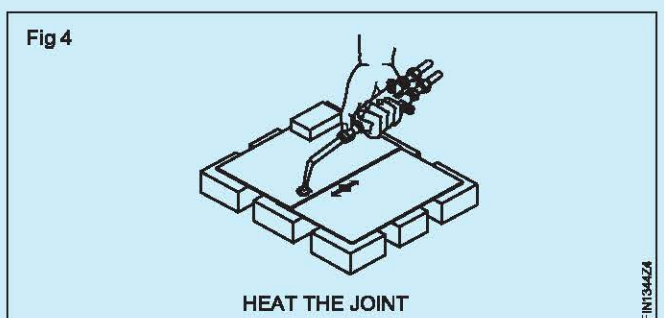

Various sheet metal joints

Objectives: At the end of this exercise you shall be able to

- make a single hemming and double hemming joints
- make a paned down seam joint by using hand tools
- make a knocked up seam joint by using hand tools
- make a locked groove joint using hand grooves
- make a straight edge wired joint by hand process.

TASK 1

50
6(TYP)

BENDING LINE
100
SINGLE HEMMING BY HAND DROCESS
BENDING LINE

TASK 2

34
7
7

BENDING LINE
100
DOUBLE HEMMING BY HAND DROCESS

1	ISSH 105 x 70 x 0.6		G.I SHEET		TASK 1	
2	ISSH 105 x 70 x 0.8		G.I SHEET		TASK 2	1.3.45
NO.OFF	STOCK SIZE	SEMI-PRODUCT	MATERIAL	PROJECT NO.	PART NO.	EX. NO.
SCALE 1:1					DEVIATIONS ±0.04	
SHEET METAL JOINTS					TIME	
					CODE NO. F120N1345E1	

TASK 3

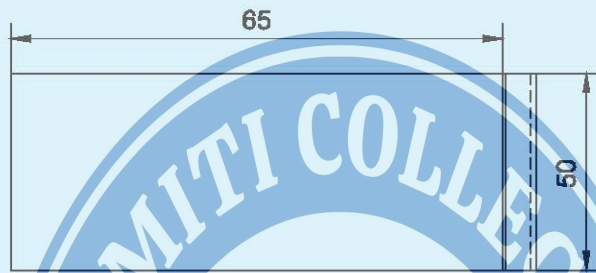
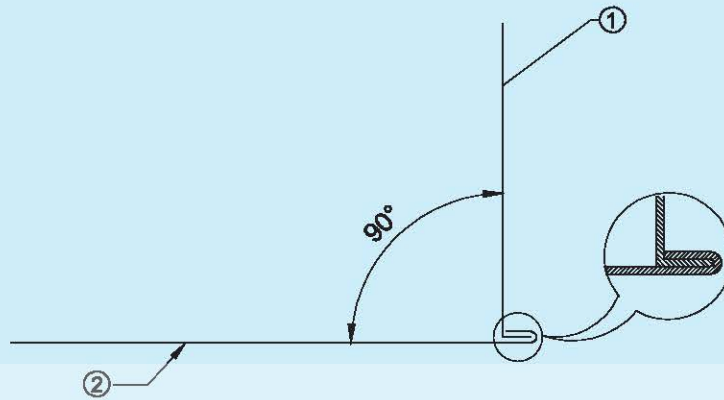

PANE DOWN SEAM JOINT

Skill India
कौशल भारत - कुरुल भारत

NCVT
Industrial Training Institute

TASK 4

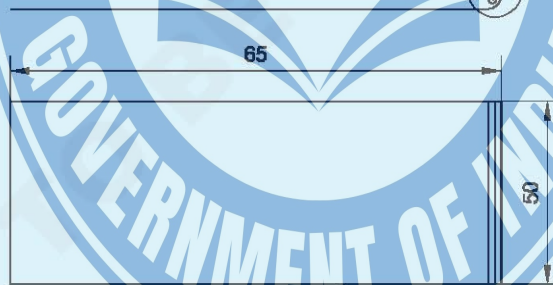

KNOCKED UP JOINT

KNOCKED UP SEAM JOINT (SINGLE SEAM)

1	ISSH 75 x 50 x 0.6		GI SHEET			TASK 3
1	ISSH 75 x 50 x 0.6		GI SHEET			TASK 3
1	ISSH 75 x 50 x 0.6		GI SHEET			TASK 4
1	ISSH 75 x 50 x 0.6		GI SHEET			TASK 4
NO.OFF	STOCK SIZE	SEMI-PRODUCT	MATERIAL	PROJECT NO.	PART NO.	EX. NO. 1.3.04
SCALE 1:1		SHEET METAL JOINTS			DEVIATIONS	TIME
					CODE NO. FI20N1345E2	

TASK 5

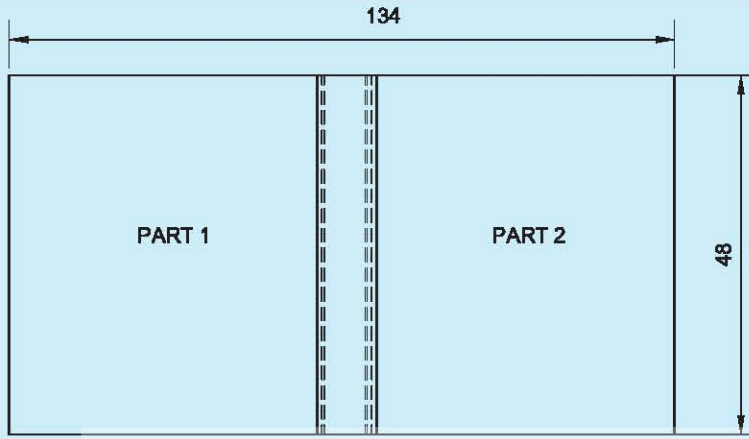

TASK 6

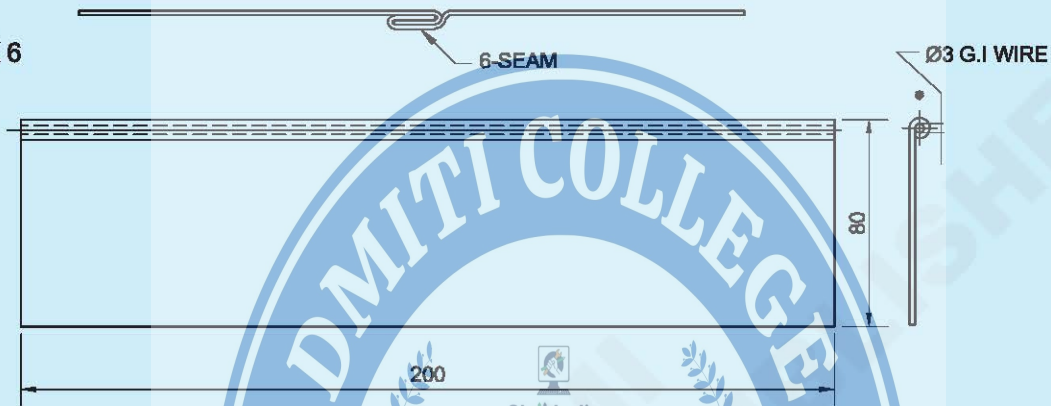

MARKING A STRAIGHT EDGE WIRED JOINT (BY HAND PROCESS)

TASK 7

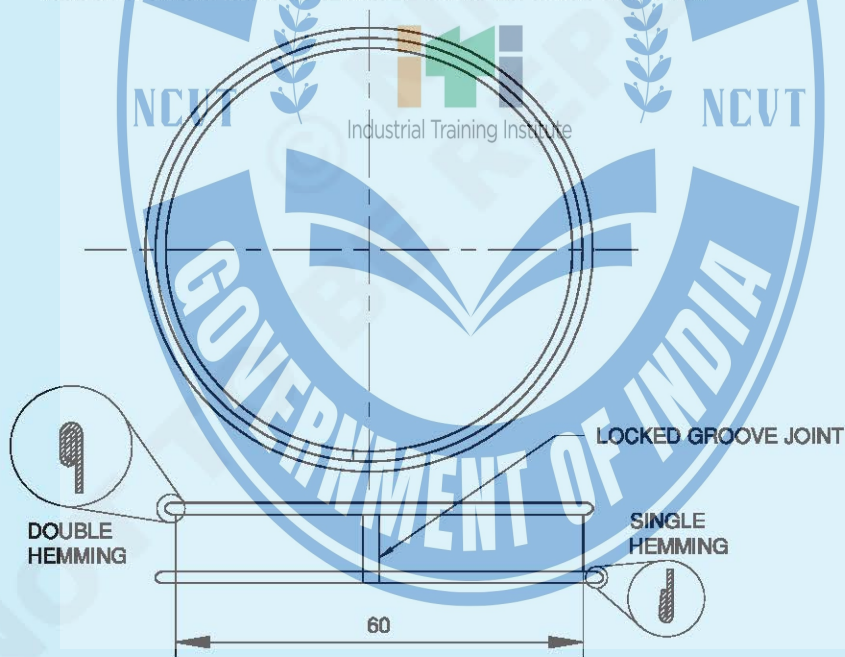

SINGLE HEMMING AND DOUBLE HEMMING ON CURVED EDGES

1	ISSH 204 x 34 x 0.5		G.I SHEET			TASK 7
2	ISSH 100 x 160 x 0.508		G.I SHEET			TASK 5
1	Ø3 - 205		G.I SHEET			TASK 6
1	ISSH 210 x 95 x 0.5		G.I SHEET			TASK 6
NO.OFF	STOCK SIZE	SEMI-PRODUCT	MATERIAL	PROJECT NO.	PART NO.	EX. NO. 1.3.45
SCALE 1:1	<p>LOCKED GROOVED JOINT MARKING A STRAIGHT EDGE JOINT (BY HAND PROCESS)</p>				DEVIATIONS ±0.04	TIME
					CODE NO. F120N1345E3	

Job Sequence

TASK 1: Single hemming by hand process

- Mark and cut the sheet as per drawing (ISSH 100 x 62 x 0.6mm GI sheet)
- Flatten the sheet using a mallet on a dressing plate. (Fig.1)

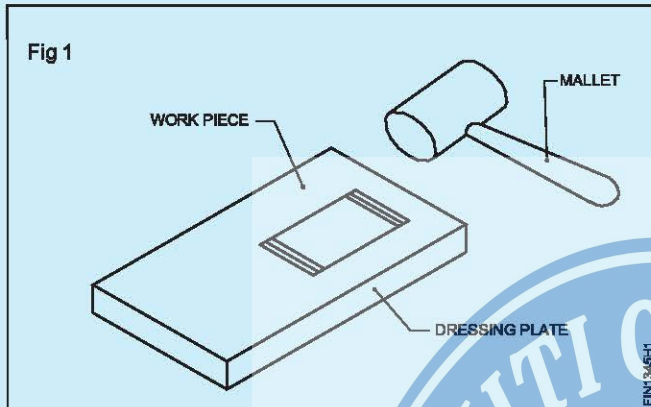

- Fold one edge of the sheet using a hatchet stake and a mallet for single hemming. (Fig.3)

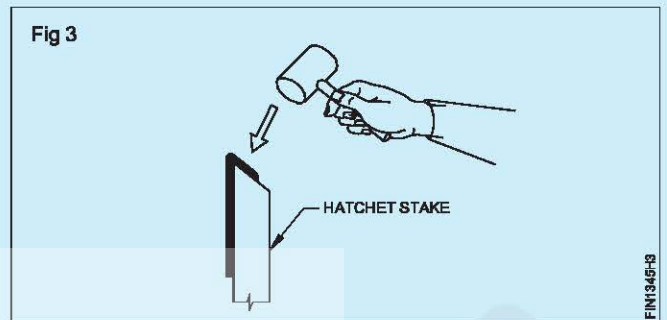

- Flatten the single hemmed edge of the job sheet metal on the dressing plate using a mallet. (Fig.4)



- Remove burrs on edges of the sheet with flat smooth file.
- Mark two lines at a distance of 6mm from both edges for single hemming with folding clearance. (Fig.2)

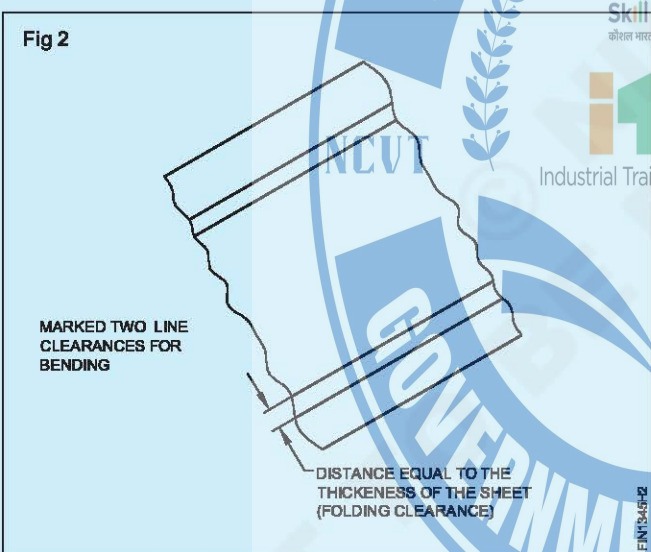

- Similarly, repeat the above process in another edge for single hemming.

- Check the flatness and the straightness of the single hemmed job of sheet metal.

- Examine the single hemming edges without gap.

TASK 2: Double hemming by hand process

- Mark and cut the sheet as per drawing. (ISSH 100x66x0.6mm G.I. sheet)
- Flatten the sheet using a mallet on a dressing plate.
- Remove burrs on edges of the sheet with flat smooth file.
- Mark two lines at a distance of 6mm from both edges for single hemming with folding clearance.
- Fold one edge of the sheet using a hatchet stake and a mallet for single hemming. (Fig.1)



- Flatten the single hemmed edge of the job sheet metal on the dressing plate using a mallet. (Fig.2)

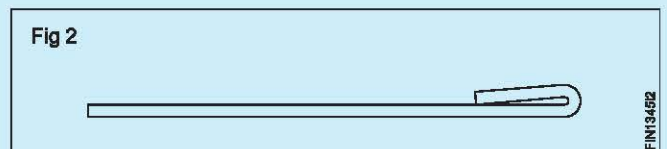

- Mark again, the two lines at a distance of 6mm from the single hem for double hemming. (Fig.3)

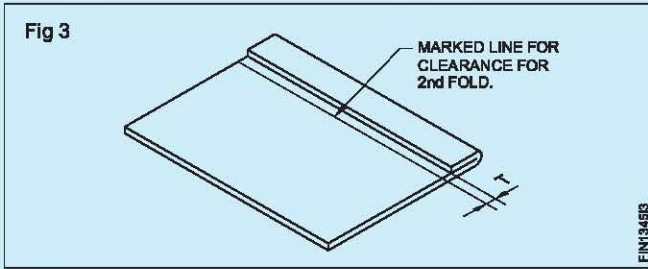

- Fold the single hemmed edge of the job sheet metal using a hatchet stake and a mallet for double hemming. (Fig.4)

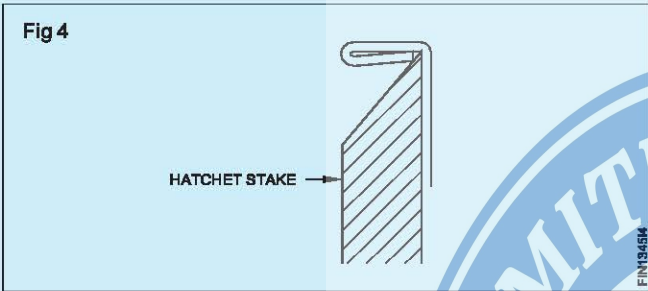

- Flatten the double hemmed edge of the sheet metal on the dressing plate using a mallet (Figs 5 & 6)

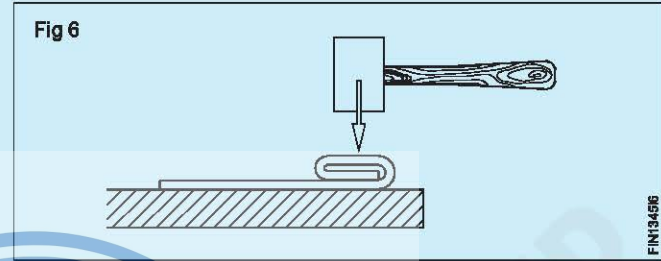
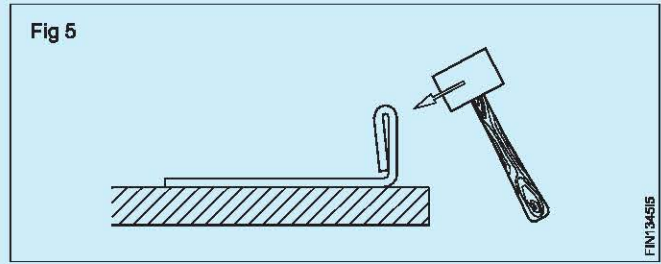

- Similarly, repeat the above process in another edge for double hemming.
- Check the flatness and the straightness of the double hemmed job of sheet metal.
- Examine the double hemming edges without gap.

TASK 3: Paned down seam joint

- Mark and cut sheet to the size as per drawing (Part I ISSH 60 x 50 x 0.6mm G.I. sheet) (Part II ISSH 80x50x0.6mm G.I. sheet)
- Flatten the sheets using a mallet on a dressing plate.
- Remove burrs on edges of the sheet with flat smooth file.
- Mark the setting down operation for the single seam (paned down joint) in part 1.

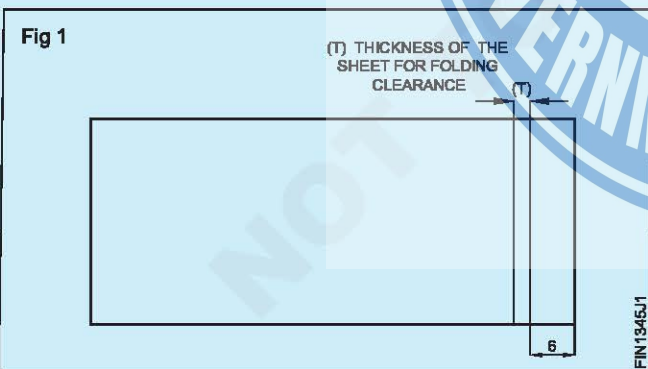

- Fold edge of the sheet to 90° using a hatchet stake and a mallet for single seam in part 1 (Fig.2)
- Mark the setting down operation for the single seam in part 2 (paned down joint) (Fig.3)

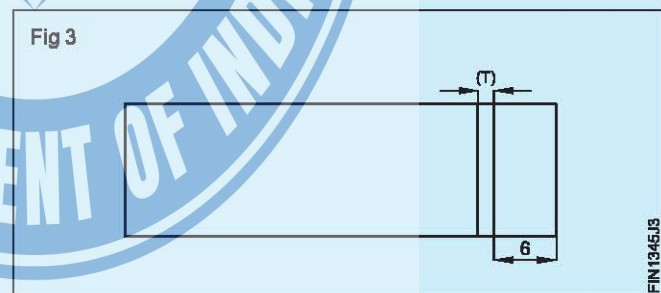
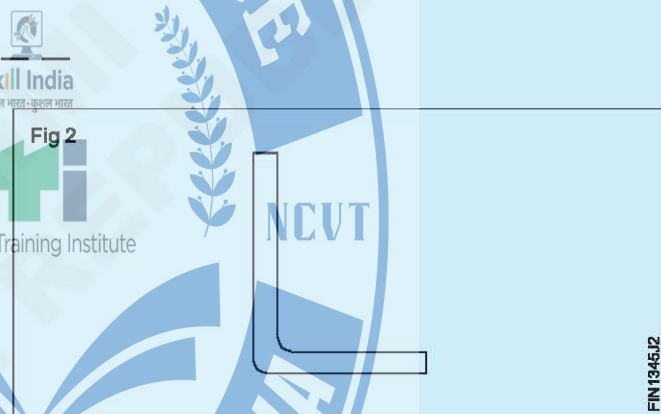

- Fold edge of the sheet using a hatchet stake and a mallet for single hemming in part 2 (Fig.4)

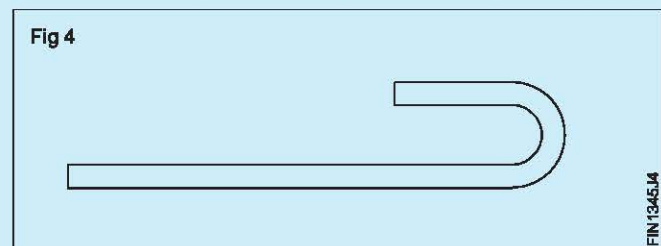

- Set the part 1 and 2 using try square as per shown in the sketch for single seam pane down joint. (Fig.5)

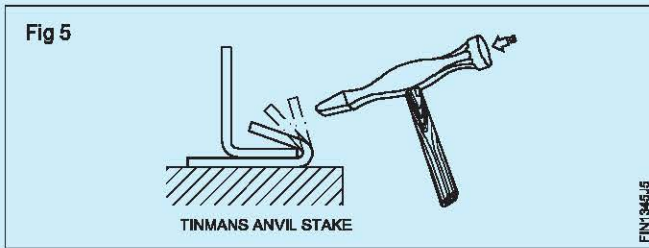

- Strike on the edge of the flange and complete, the operation for the paned down joint. (Figs 6 & 7)
- Examine the paned down joint, without gap.

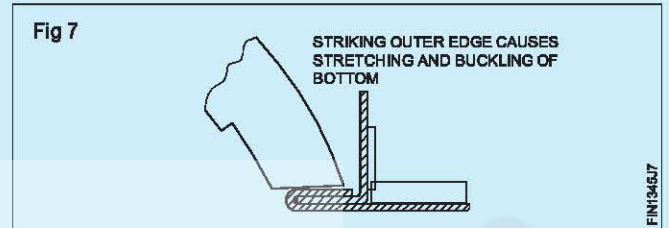
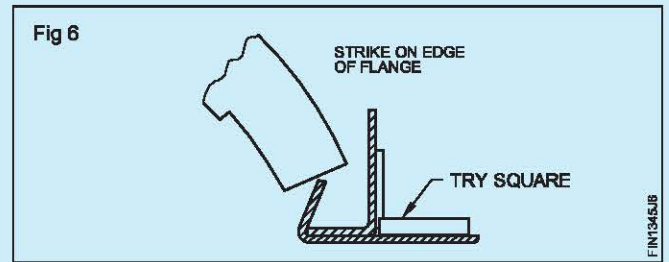

TASK 4: Knocked up seam joint (single seam)

- Mark and cut sheet to the size as per drawing.
(Part 1 ISSH 65x50x0.6 G.I SHEET)
(Part 2 ISSH 85x50x0.6 G.I SHEET)
- Flatten the sheet using a mallet on a dressing plate.
- De-burr on edges of the sheet with flat smooth file.
- Mark the setting down operation for the single seam in part 1 (knocked up seam joint) (Fig.1)

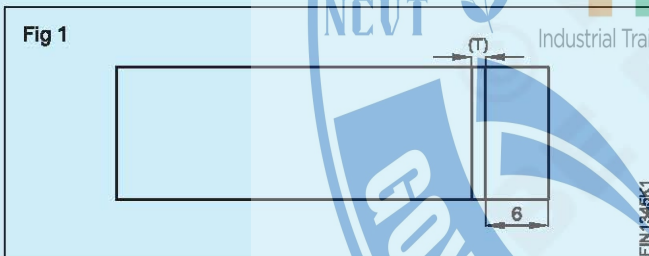

- Form the edge of the sheet using a hatchet stake and a mallet for single seam in part 2. (Fig.4)

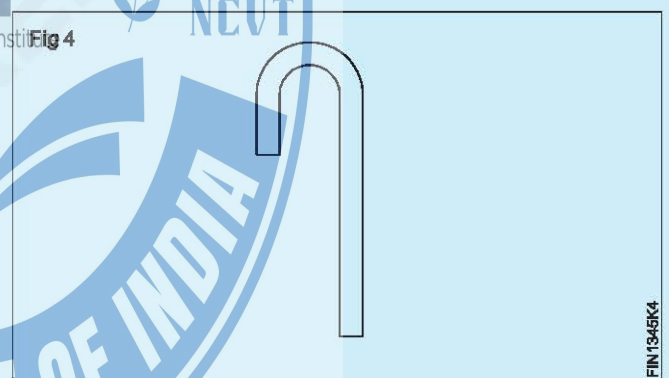

- Fold to form the edge of the sheet using a hatchet stake and a mallet for single seam in part 1. (Fig.2)

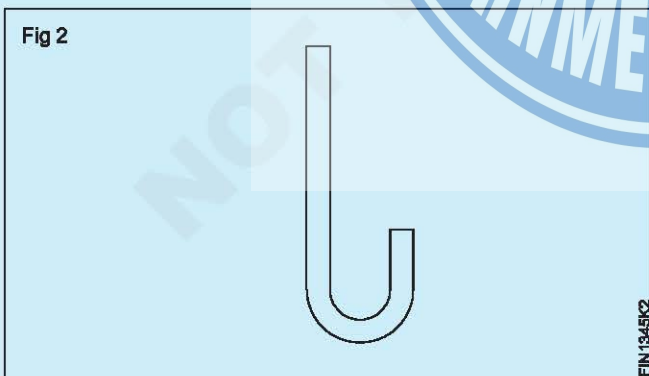

- Mark the distance in part 2 for single seam (Fig.3)

- Set the job part 1 and part 2 on a half moon stake and join bent leg with a mallet as shown in figure. (Fig.5)

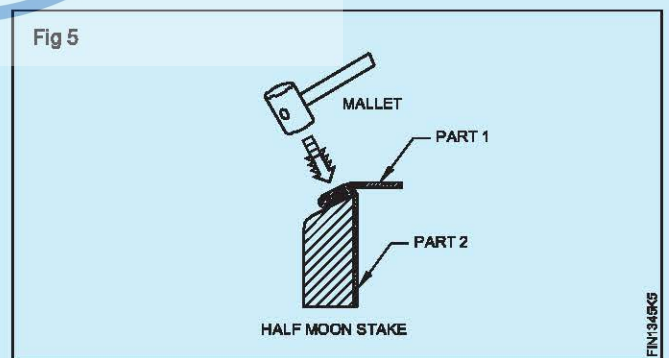

- Support the job by hand and strike with the mallet all around to an angle as shown in figure to form knocked up joint. (Fig.6)

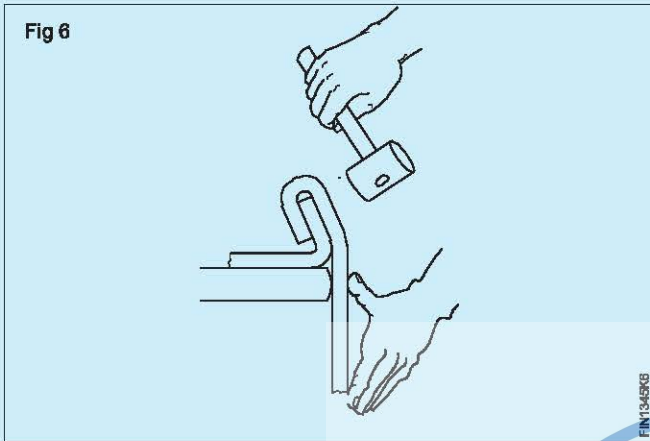

- Increase the angle of the bend gradually while striking with the mallet all around the seam as shown in figure to form knocked up joint. (Fig.7)

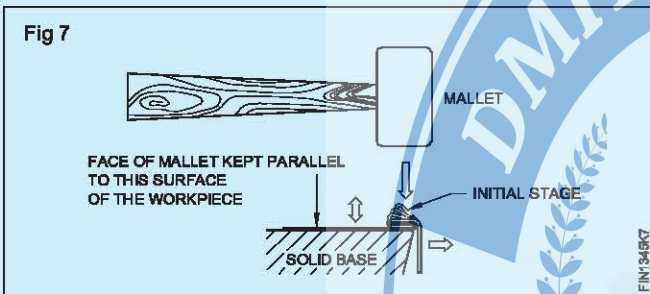

TASK 5: Locked grooved joint

- Mark and cut the sheet into two pieces as per drawing Part 1 and Part 2 - ISSH 75x60x0.6 mm each one
- Flatten the sheet metal.
- De-burr on edges of the sheet.
- Determine the fold size of the given seam.
- Mark the straight lines for folding on the two sheets using a steel rule and a scribe as shown in fig.1

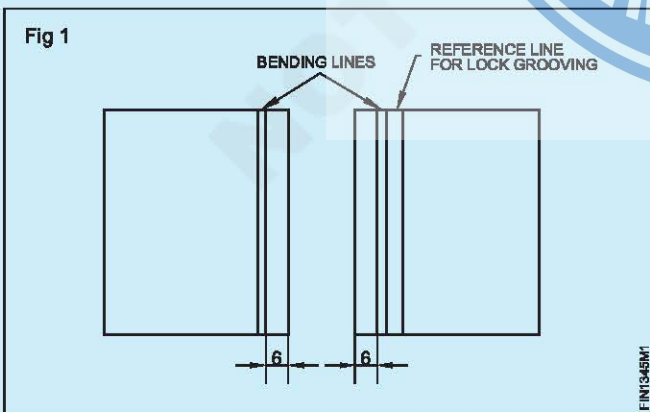

- Fold the two sheets to an acute angle on the marked line using a hatchet stake, steel plate / hammering block and a mallet to form the hooks as shown in fig.2.

- Tighten the double seam (knocked up joint) using the planishing hammer as shown in figure. (Fig.8)

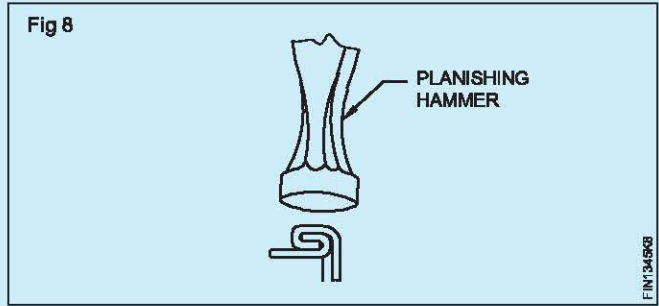

- Place the edge of the joint on the square stake and lightly dress the bottom with the planishing hammer as shown in figure and finish the knocked up joint. (Fig.9)
- Examine the knocked up joint.

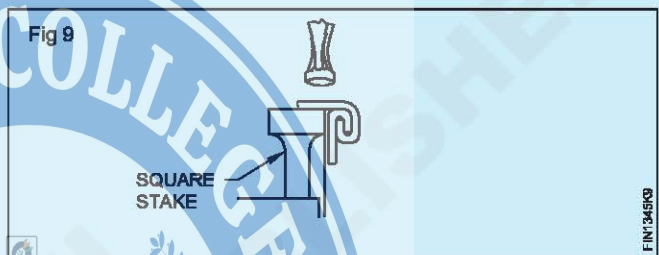

NCVT Skill India कौशल भारत - कुशल भारत Industrial Training Institute NCVT

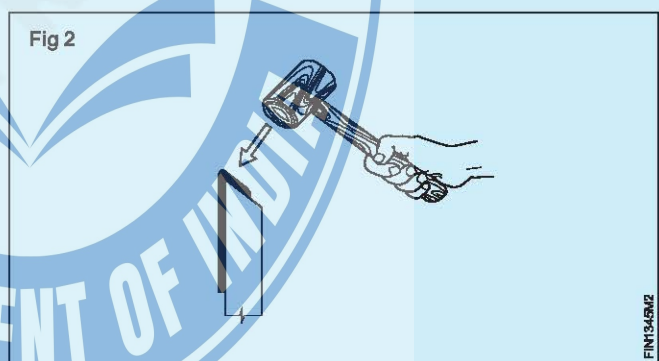

- Make the folded widths flat by filling with a scrap bend sheet of approximately 1.5 times thickness of sheet and pressing with a mallet to get the pocket for lock in two sheets. (Fig.3)

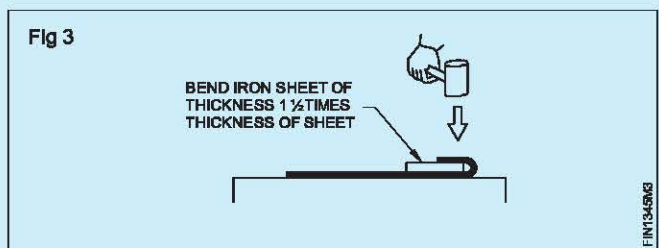

- Inter lock the folded sheets and place the sheets on the dressing plate. (Fig.4)

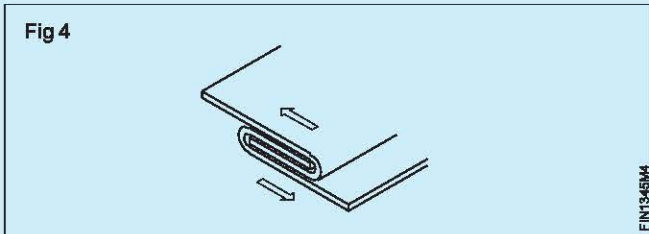

- Press the joint to close down using the wooden mallet, to get the grooved joint (seam) as shown in fig.5

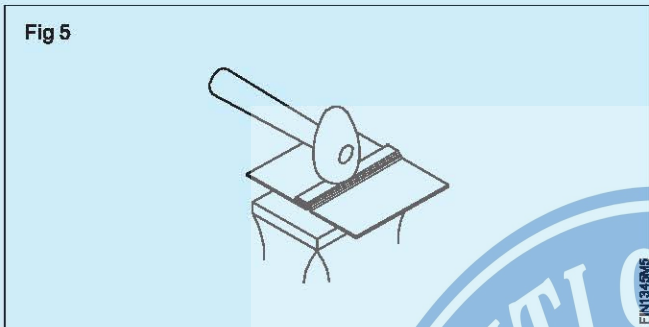

- Select the correct size of hand groover of a given width of lock (seam), as shown in fig.6.
- Place the groover over the fold and strike it using a ball pein hammer, lock the joint and finish. (Fig 7)

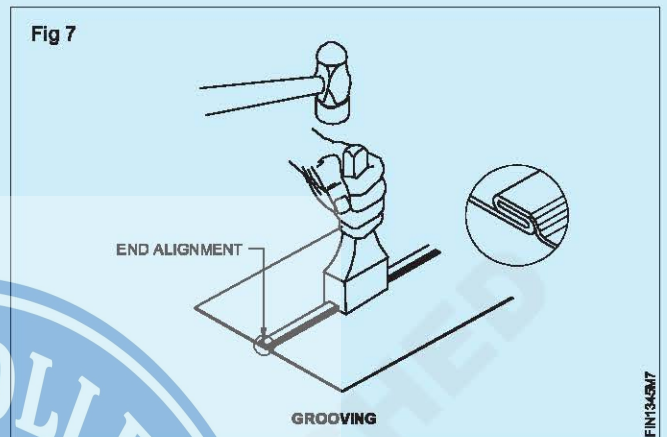
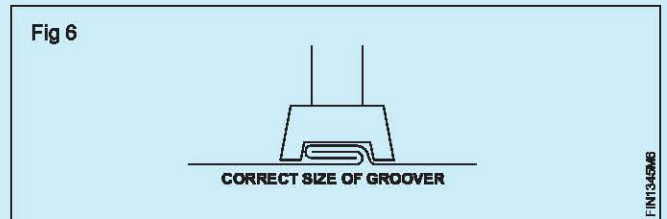

- Check the locked grooved joint to its requirement.

TASK 6: Making a straight edge wired joint by hand process

- Mark and cut sheet as per drawing (ISSH 215 x 95 x 0.6mm G.I. sheet)
- Flatten the sheet using a mallet on a dressing plate
- De-burr on edges of the sheet.
- Determine the total length of the sheet for edge wired joint.
- Mark two lines parallel to the edge of the sheet metal at a distance of 1/4th of the total wiring allowance.
- Fold at the first line nearer to the edge at right angle on the steel plate or the hatchet stake using a wooden mallet.
- Make an another fold at the second marked line to 30° on a hatchet stake using a wooden mallet.
- Use a wire of given diameter slightly longer than the length of the edge to be wired.
- Place the wire at the folded edge and tap the edge by a wooden mallet using an anvil or anvil stake as shown in fig.1

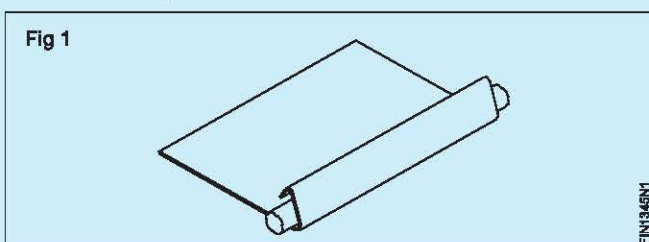

- Form the edge around the wire by striking the wooden mallet as shown in fig.2

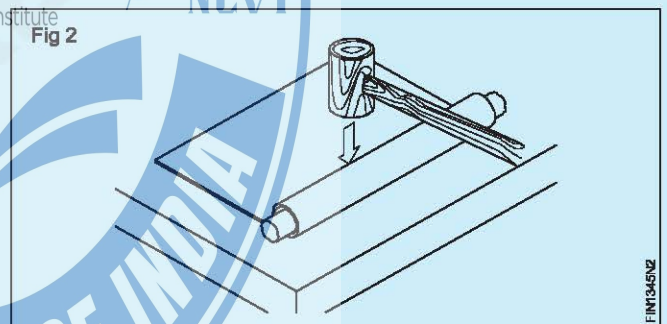

- Finish the wired edge, on the edge of the anvil or anvil stake by striking the wooden mallet in different direction as shown in the fig.3 & 4.

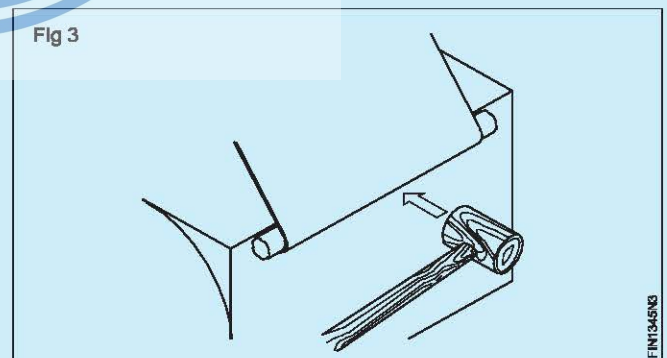

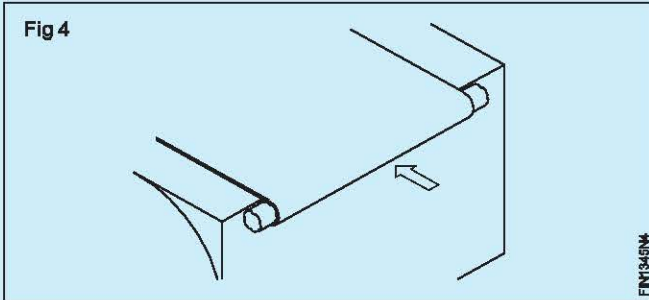

- Finally, finish the wired edge on a hatched stake as shown in the fig.5
- Cut off the surplus wire at the ends using hacksaw (Hacksaw blade fitted with hacksaw frame).

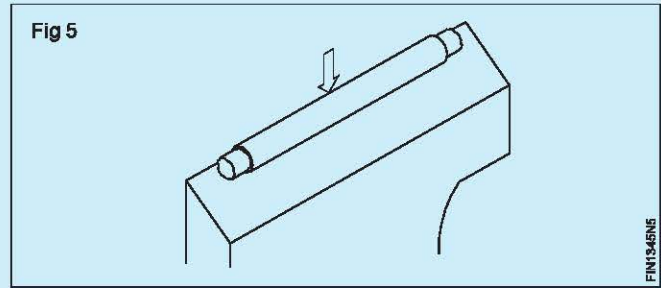

- File the wire ends by a flat smooth file.
- Examine the straight edge wired joint.

TASK 7: Single hemming and double hemming on curved edge

- Develop and layout the pattern for the cylinder (Fig 1) with all allowances for joining and hemming on drawing sheet by parallel line method.

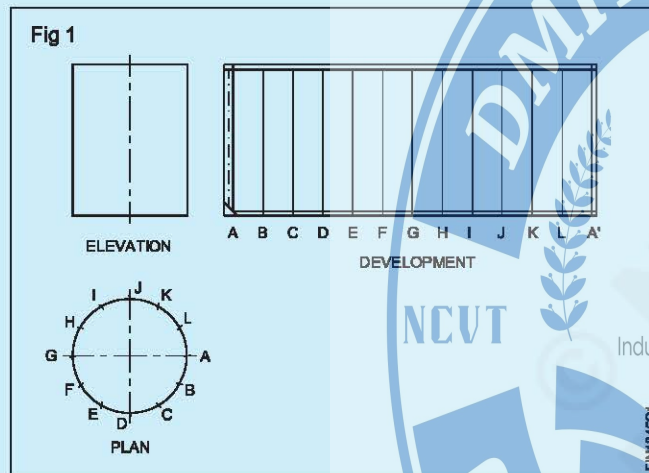

- Check the pattern for its correctness.
- Ensure the correct size of the material.
- Cut the pattern and paste it on the given sheet metal with gum.
- Cut the pattern with notches using 12" straight snips.
- Deburr the edges using a flat smooth file 150 mm long.
- Fold the edges of the sheet metal pattern using a hatchet stake and a mallet in the form of hooks for making the lock grooved joint. (Fig 2) (Ref. Skill Sequence)

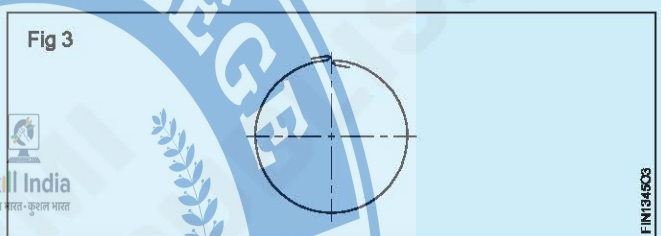
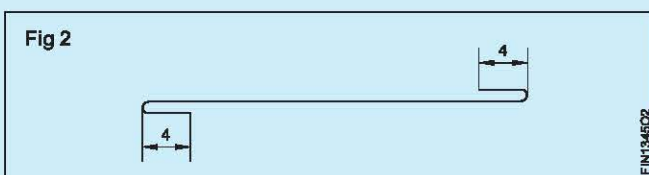

- Form the sheet metal pattern to cylindrical shape using a round mandrel stake and a mallet. (Fig 3) (Ref. Skill Sequence)
- Hook the folded edges and make the lock grooved joint using a hand groover. (Fig 4) (Ref. Skill Sequence)

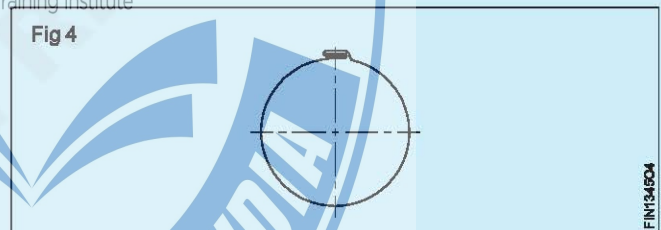

- Make single hemming on one end and double hemming on the other end of the cylinder using a hatchet stake and Tinman's anvil. (Ref. Skill Sequence)
- Dress the cylinder to regular round shape using a round mandrel stake and a mallet. (Fig 5)
- Check the roundness of the inside diameter of the cylinder using gauge.

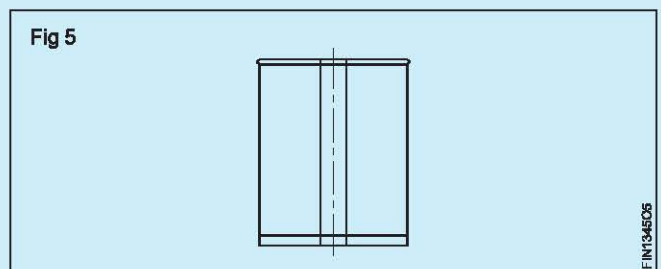

Skill Sequence

Folding at right angle using a hatchet stake

Objective: This shall help you to

- fold the sheet metal at right angle using a hatchet stake and a mallet.

Mark the folding line on the workpiece.

Hold the workpiece horizontal by one hand as shown in Fig 1.



Position the marked folding line on the bevelled edge of the hatchet stake.

By other hand, strike the edge of the workpiece at both ends by the wooden mallet, using slightly angular motion.

Ensure that folding takes place at the marked folding line at both ends.

Lower the end of the workpiece slightly. (Fig 2)

Strike the edge of the workpiece using the same angle of striking.

Strike the edge of the workpiece from one end, progressing gradually, towards the other end. This will give uniform folding.

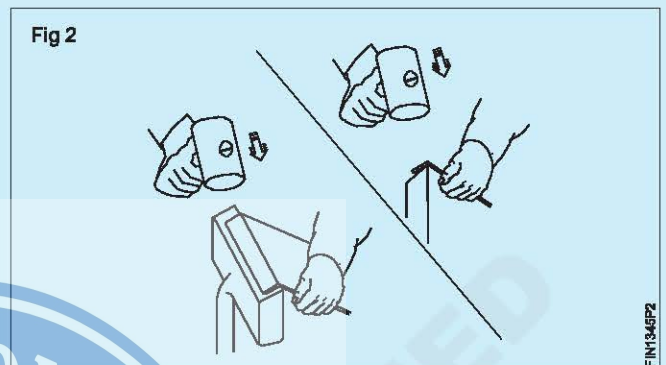

Now place the workpiece vertically as shown in Fig 3 and Fold the edge to approximately 90°.

Check the perpendicularity using a try-square.

Rectify if necessary, by the previous method.

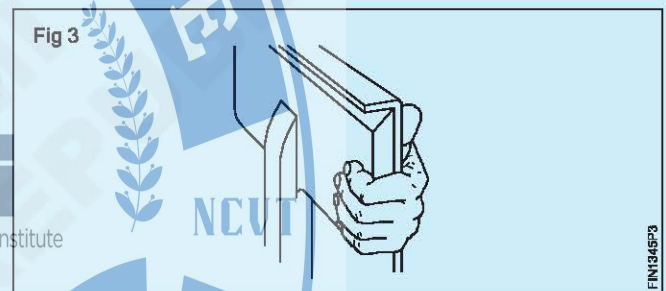

Single hemming

Objective: This shall help you to

- make single hemming at the edge of the sheet using a hatchet stake.

Fold the edge of the workpiece to approximately 90° using a hatchet stake and a wooden mallet. (Ref. Skill sequence of folding at right angle using a hatchet stake)

Placing the workpiece vertically on the hatchet stake as shown in Fig 1, increase the angle of bend, by striking with the wooden mallet. (Fig 2)

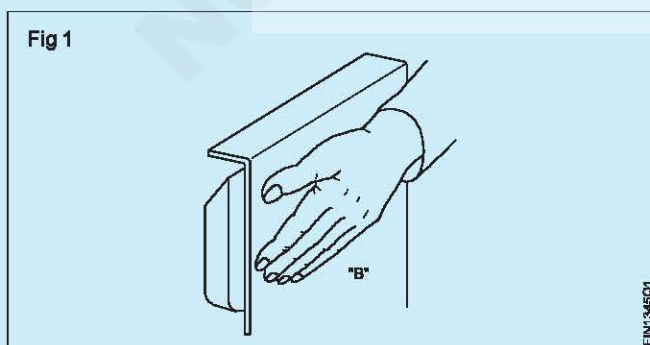

Place a piece of waste sheet and flatten the edge as shown in Fig 3.

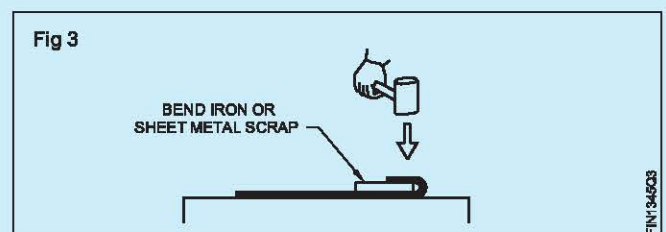
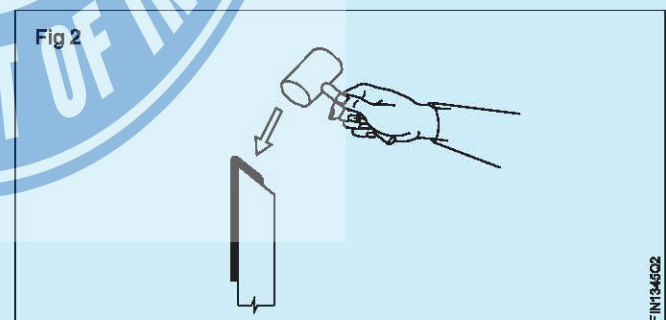

Remove the waste piece and edge down the fold by striking it with end faced mallet in angular position as shown in Fig 4.

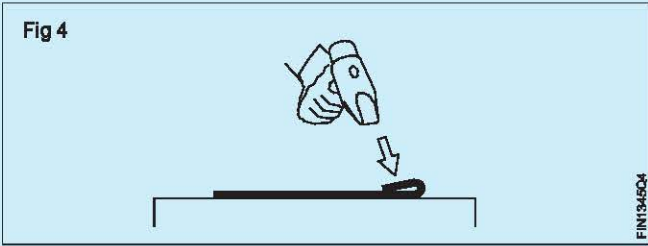

Examine the edge for any gap between the edge and the surface of the workpiece. (Fig.5)

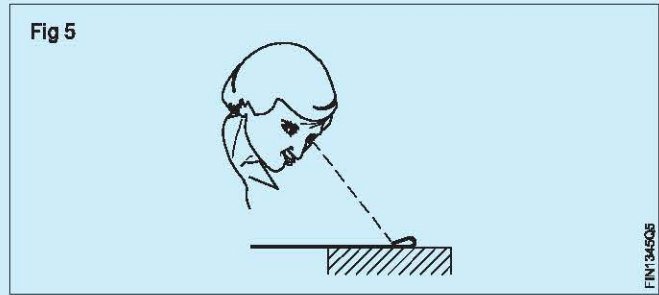

If any, finish the edge to get uniform hemming.

Do not crush the folded portions excessively while bending otherwise it may crack.

Marking and folding

Objectives: This shall help you to

- mark the allowance for double hemming
- do double hemming on the edges of the sheet using a hatchet stake.

Mark the first hemming allowance equal to double hemming dimensions i.e., 2 times the thickness of the sheet to be used.

Fold the sheet metal; edge to be folded more than 90° on the hatchet stake using a mallet. (Fig 1)



Flatten the folded edge on the dressing plate using the mallet. Ensure that there is no gap between the folded edges. (Fig.2)

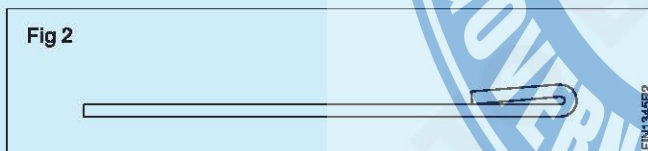

Mark a line from the folded edge at a distance equal to the thickness of the sheet, providing clearance for the second fold. (Fig3)

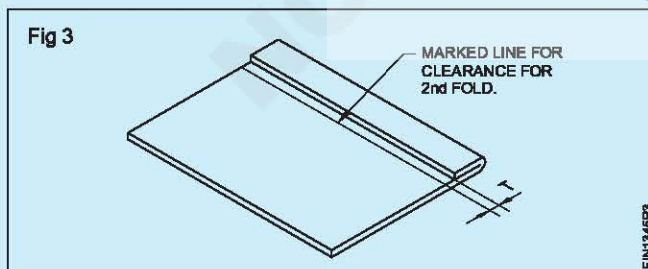

Hold the workpiece vertical, set the marked line matching with the beveled edge of the hatchet stake and fold the edge to approximately 90° using a mallet. (Fig 4)

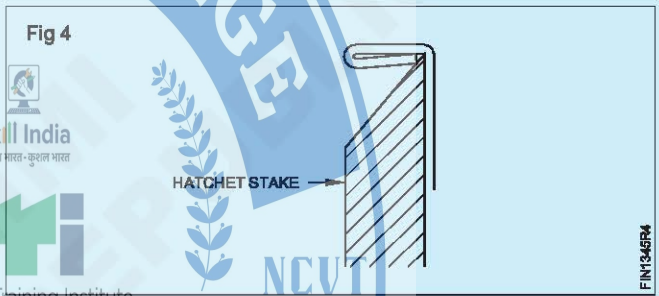

Now fold the edge further on the dressing plate using the mallet. (Fig 5)

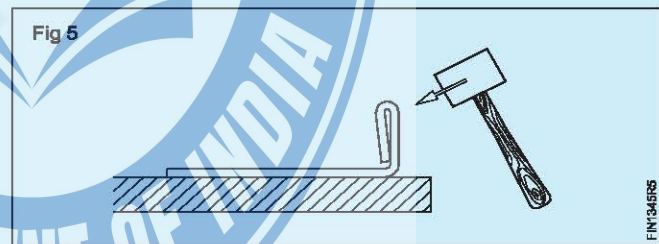

Flatten the edge, without any gap, using the mallet. (Fig.6)
Check the double hemmed edge for flatness and straightness.

Rectify, if necessary.

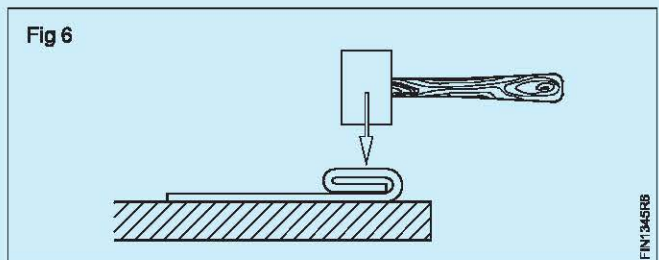

Paned down joint

Objective: This shall help you to

- set the part and finish the paned down joint (single seam).

The setting down operation for the single seam (paned down joint) should be carried out stage by stage as shown in (Fig 1)

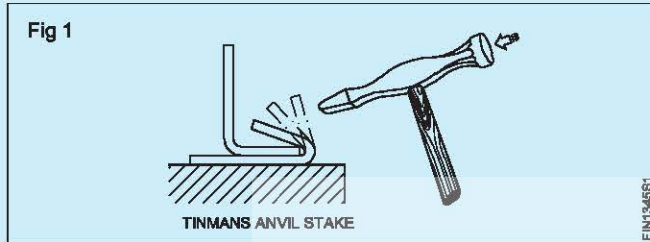

While striking, stretching and buckling of the metal is occurred at the bottom edge (Fig 2)

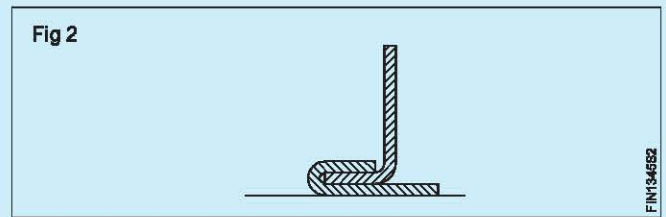

The finished single seam (paned down joint) is shown in (Fig 3)

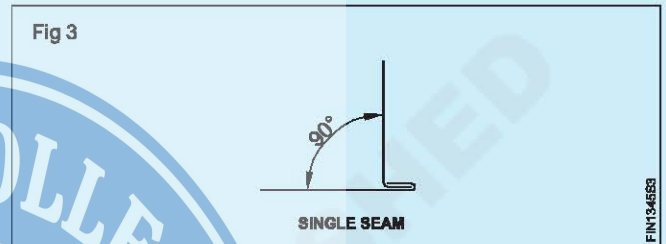

Setting and double seaming

Objectives: This shall help you to

- place the joint on half moon stake and square stake
- finish the knocked up joint (double seam)

For knocked up seam, the paned down joint is turned up. Place the paned down joint on a half moon stake and join

by a mallet as shown in Fig 1. Increase the angle of the bend gradually, while striking with the mallet all around the seam as shown in Fig 3.

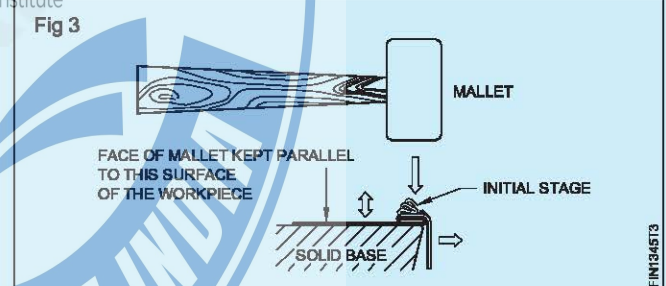
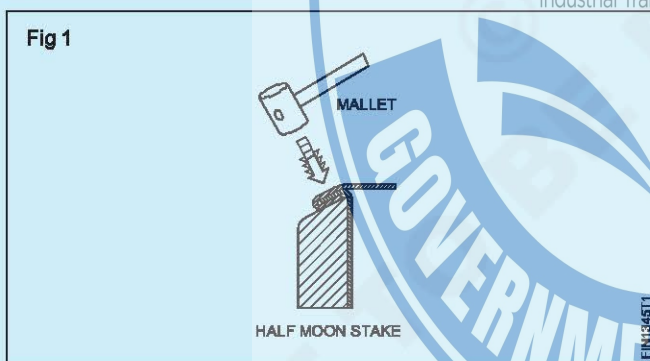

Support the job by hand and strike with the mallet all around to an angle as shown in Fig 2.

Tighten the double seam (knocked up joint) using the planishing hammer s shown in Fig 4.

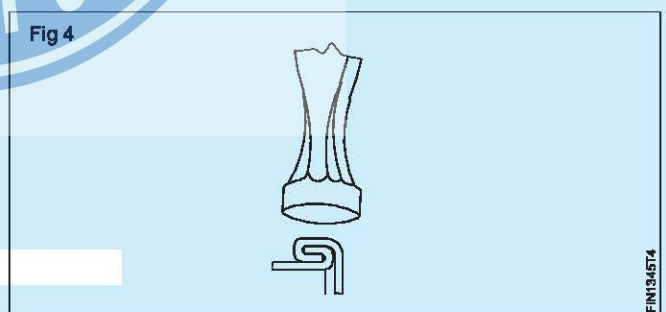
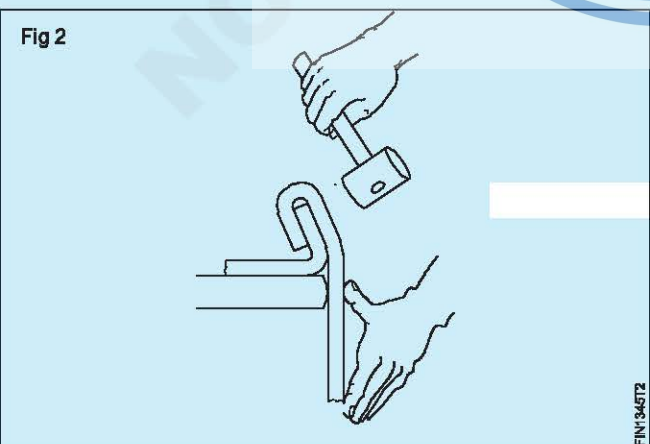

Place the edge of the joint on the square stake and lightly dress the bottom with the planishing hammer as shown in Fig 5.

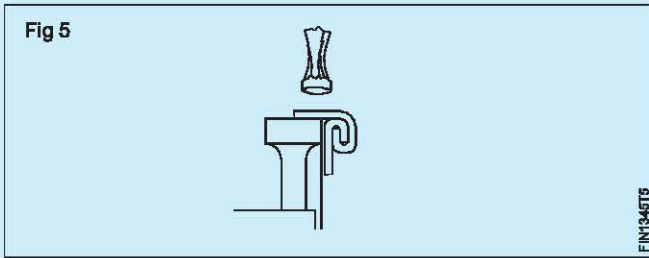

The Finished double seam (knocked up joint) is shown in Fig 6.

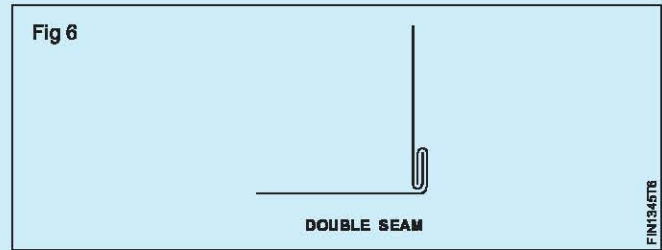

Marking and forming lock grooved joint

Objectives: This shall help you to

- mark the allowance for double hemming
- make double hemming at the edges of a sheet metal using a hatchet stake.

First determine the fold size for the given width of the seam.

Fold size = Width of the lock - 3 times the material thickness.

Now from the fold size determine the total allowance for the locked grooved joint.

Total allowance = (3 x the fold size) + (6 x the thickness of the sheet)

For example, if the width of the lock is 6mm and the thickness is 0.5 mm then, the fold size = $6 - (3 \times 0.5) = 4.5\text{mm}$

The total allowance = $(3 \times 4.5) + (6 \times 0.5) = 13.5 + 3 = 16.5\text{mm}$.

Mark the line at a distance of $\frac{1}{3}$ rd of the total allowance on one sheet and two lines at a distance of $\frac{1}{3}$ rd and $\frac{2}{3}$ rd of the total allowance on another sheet.

For example, if the total allowance is 16.5 mm then, mark the line at a distance of 5.5mm from the edge on one sheet and two lines at a distance of 5.5mm and 11.00mm from the edge on another sheet (Fig 1)

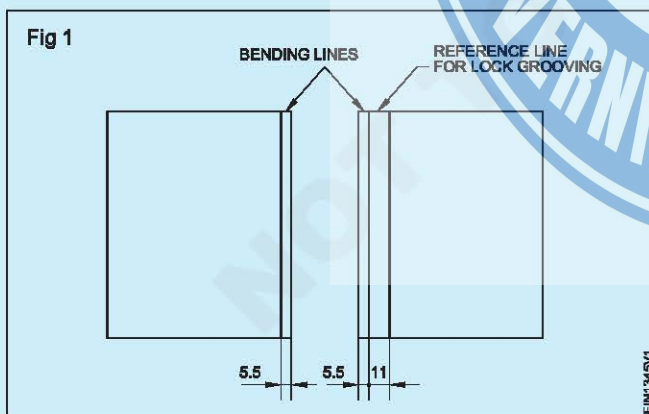

Fold the workpiece to more than 90° on the hatchet stake using a wooden mallet (Fig 2) and then place the bend sheet of 1.5 times the thickness as shown in Fig 3 and flatten the edge using the wooden mallet. This looks like a hook.

Make a similar hook on the other workpiece also.

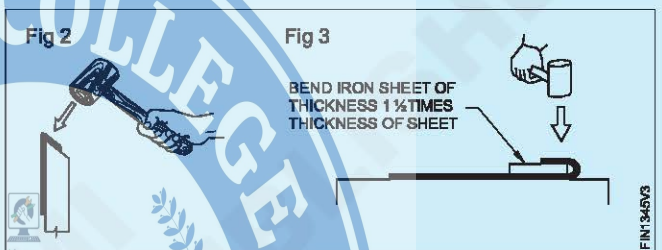

Interlock and place the workpiece on the dressing plate. (Fig 4)

While interlocking, ensure that the interlock is parallel and tight at both ends visually.

Press the joint to close down using the wooden mallet, to get the grooved joint (seam). (Fig 5)

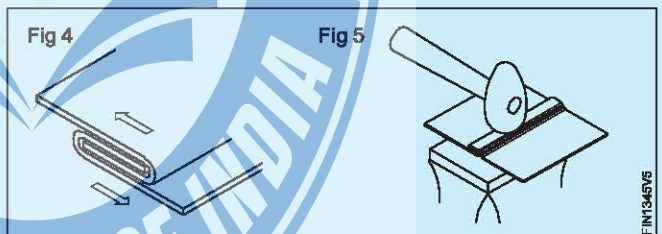

Select the hand groover of a given width of the lock (seam). If proper size groover is not used, it may cause improper locking of the grooved joint (Fig 6)

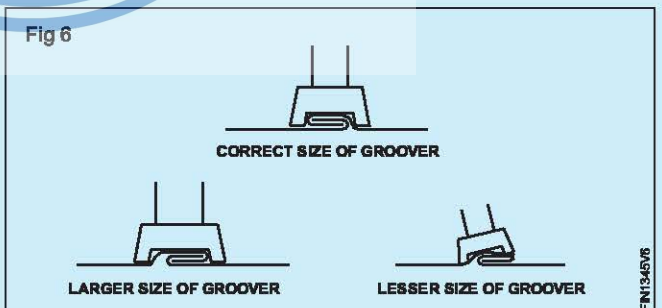

Place the groover over the fold at one end as shown in Fig.7

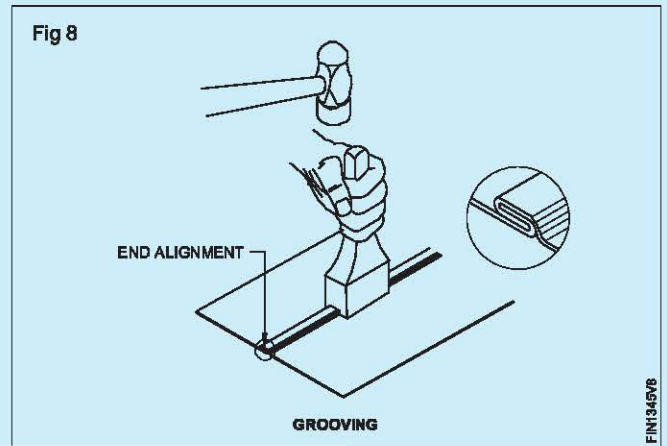
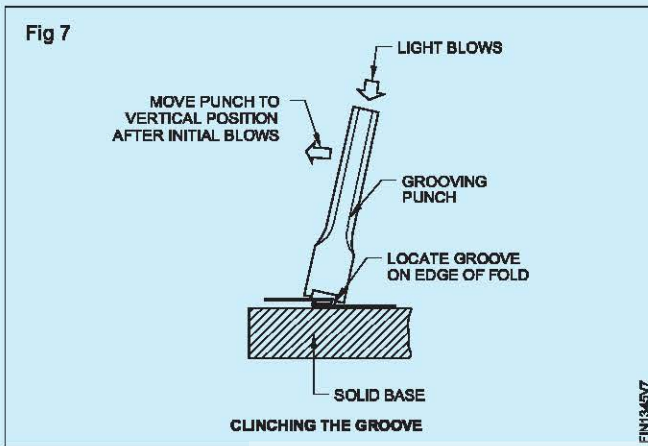

Hold the hand groover in one hand and strike the top of the groover with ball pein hammer by the other hand and clinch the groove. Similarly clinch the groove at the other end.

Advance this work every 1/3 of the groover length, until the entire groove is clinched down (Fig 8)

Finish the locked grooved joint (seam) with the hand groover and the hammer.

Making wired straight edge for stiffening by hand process

Objectives: This shall help you to

- calculate the wiring allowance and total length
- form the edge around the wire and finish as a hatchet stake.

Calculate the wiring allowance for the given wire of diameter 'd' and sheet thickness 't'.

Wiring allowance = 2.5 times the diameter of the wire + the sheet thickness.

Determine the total length of the side.

Total length = length of the side + wiring allowance.

Cut the sheet metal to the required size using a straight snip.

Flatten the sheet on the dressing plate by a mallet and deburr the cut edges by a flat smooth file.

Mark two lines parallel to the edge of the sheet metal at a distance of 1/4th of the total wiring allowance.

Fold at the first line nearer to the edge at right angle on the steel plate or the hatchet stake using a wooden mallet.

Make an another fold at the second marked line to 30° on a hatchet stake using a wooden mallet.

Take a wire of given diameter slightly longer than the length of the edge to be wired.

Place the wire at the folded edge and tap the edge by a wooden mallet using an anvil or anvil stake as base. (Fig 1)

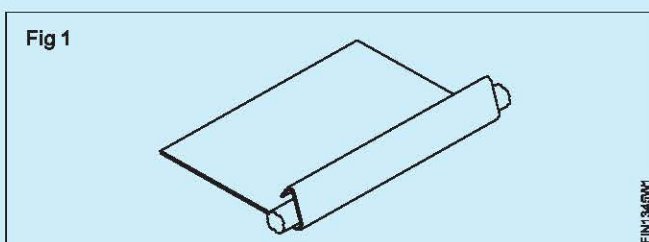

Form the edge around the wire by striking the wooden mallet. (Fig 2)

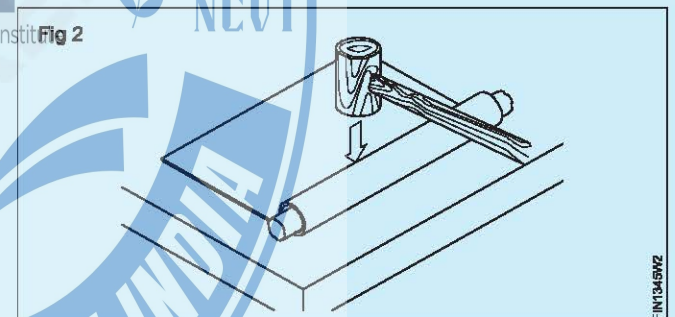

If the edge is too narrow, give blows in the direction shown in Fig 3.

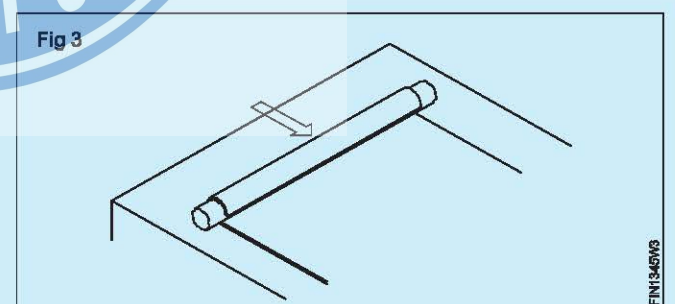

If the edge is too wide give blows in the direction shown in Fig 4.

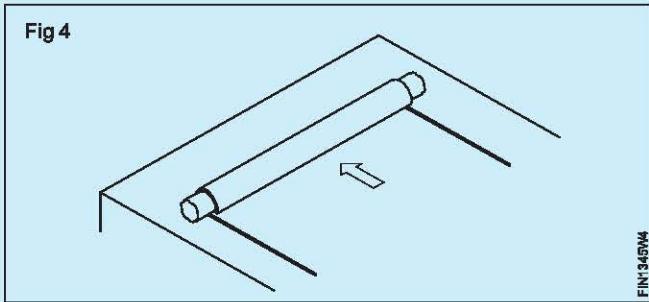

Finish the wired edge on the edge of the anvil or anvil stake by striking the wooden mallet in different directions. (Figs 5&6)

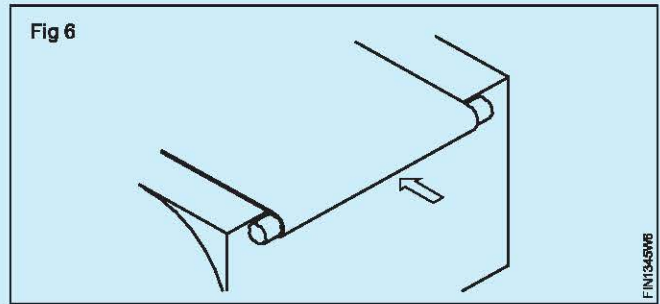
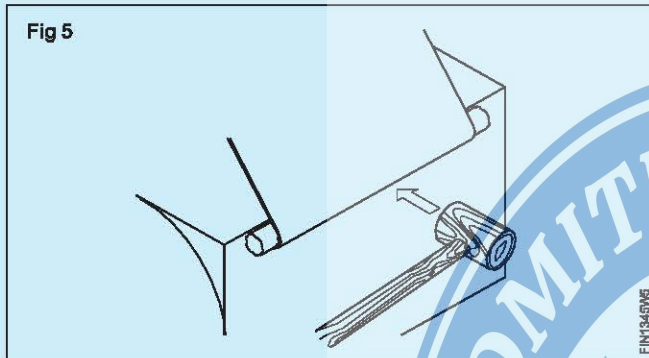

Finally finish the wired edge on a hatchet stake as shown in the Fig 7.

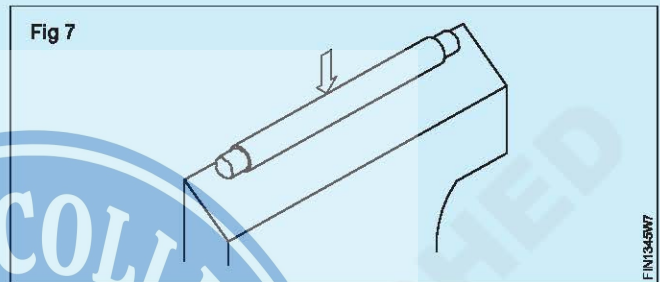

Cut off the surplus wire at the ends.
File the ends of wire using a flat smooth file.

Forming cylindrical shape by hand process

Objective: This shall help you to
 • **form a plain sheet to a cylindrical shape by hand process.**

Ensure for the correct size and shape of the pattern. (Workpiece)

Fix the mandrel stake on to the bench plate.

Set and bend the workpiece ends parallel to the axial line of the mandrel. (Fig 1)

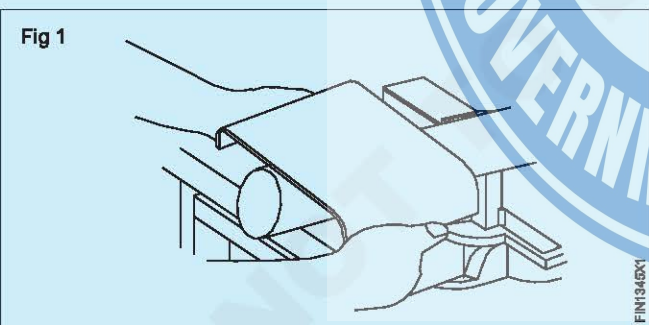

Gradually rotate and form the entire workpiece to cylindrical shape by hand. (Fig 2 & 2A)

Check the formed cylinder for the roundness of the external diameter using an external gauge. Fig 2 of skill sequence of checking the roundness.

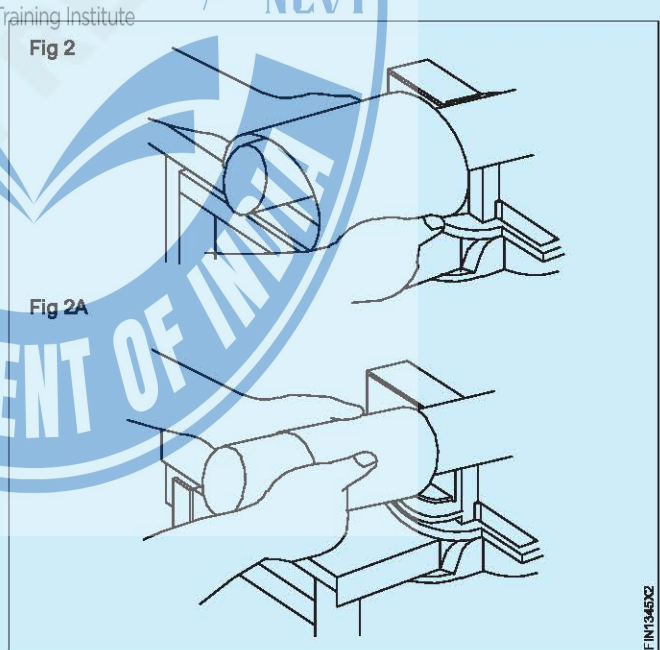

Set the workpiece parallel to the axial line of the stake. If not the edges will not match with each other as shown in Fig 3.

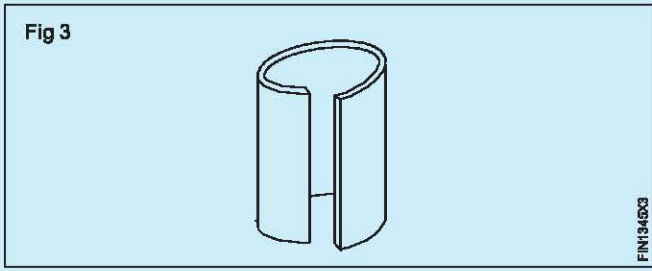

Making lock grooved joint on a cylinder by hand process

Objective: This shall help you to

- make a lock grooved joint on a cylindrical object using hand groover.

Ensure for correct marking on the pattern, for allowances for making the locked grooved joint.

Fix the hatchet stake in the vice or the bench plate.

Place and set the bending line along the beveled edge of the hatchet stake. (Fig 1)

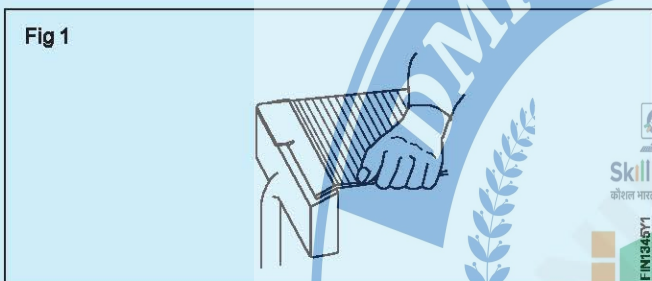

Fig 1

Set the bending line correctly on the bevelled edge of the hatchet stake, to avoid unequal folding.

Form the hooks at both ends in opposite direction using a hatchet stake and a mallet.



Fig 2

Form the sheet to cylindrical shape using a round mandrel stake. (Refer previous skill sequence).

Interlock the hooks at the ends as shown in Fig 3.

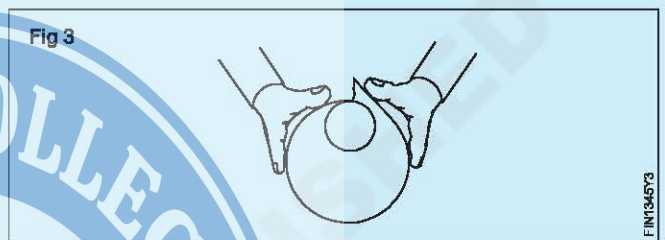

Fig 3

Close down the hooks by light blows using a mallet. This is the grooved seam. (Fig 4)

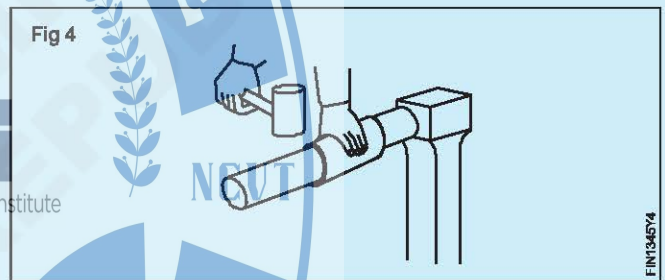

Fig 4

Lock the grooved seam with a hand groover and a hammer as shown in Fig 5.

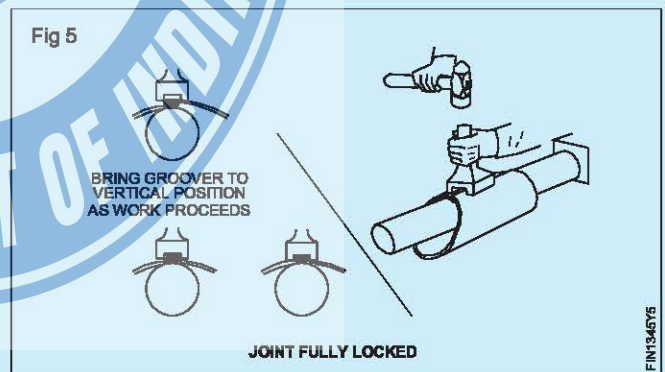

Fig 5

Dress the formed cylinder to a regular round shape using a round mandrel stake and a wooden mallet.

Make a single hemming on a curved edge

Objective: This shall help you to

- make a single hemming on a curved edge using anvil stake and setting hammer.

Mark the hemming allowance on the formed body using a marking template.

Fix the anvil stake on to the vice or bench plate.

Hold the workpiece such that the marked line coincides with the edge of the stake approximately inclined at an angle of 10° as shown in (Fig 1).

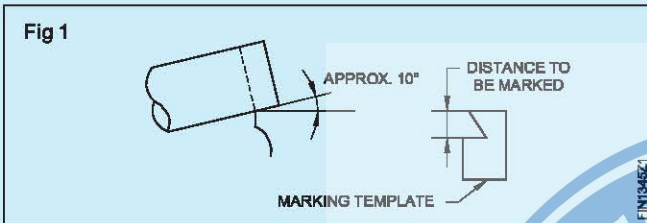

Strike and rotate the workpiece gradually along the marked line to form a small flange using a setting hammer. (Fig 2)

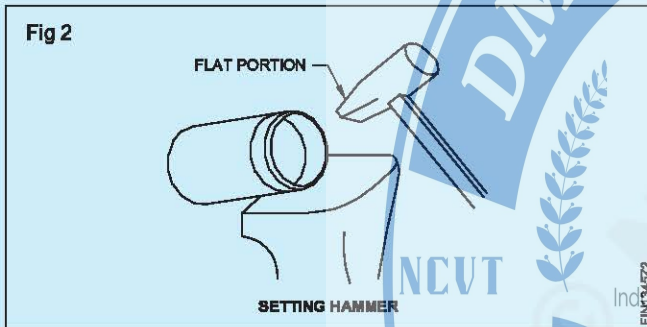

Gradually increase the angle of inclination while forming the flange as shown in Fig 3.

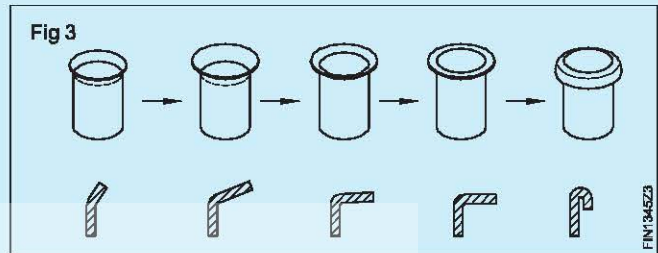

Finish the hemmed edge on a round mandrel stake by a mallet. (Fig 4)

Dress the disturbed body of the cylinder to a round shape using a round mandrel stake and a mallet.

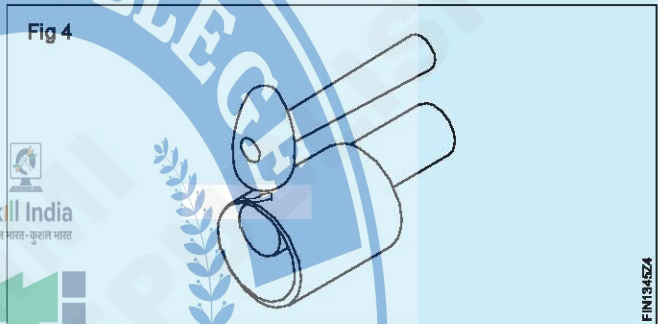

Punch holes using hollow and solid punches

Objectives: At the end of this exercise you shall be able to

- punch holes using hollow punches
- replace damaged gasket
- punch holes using solid punch.

TASK 1

Ø8, R8, 62, 78, 48, 2

TASK 2

25, 1.6, 30, 90, R15

Ø6 - 2 HOLES (HOLES TO BE PUNCHED WITH SOLID PUNCH)

RUBBER SHEET 2.0 THICK

30

Industrial Training Institute

1	ISSH 145 x 40 x 1.6		G.I SHEET			1.3.46
1	78x48x2.0	-	RUBBER	01	-	1.3.46
NO.OFF	STOCK SIZE	SEMI-PRODUCT	MATERIAL	PROJECT NO.	PART NO.	EX. NO.
SCALE 1:1					TOLERANCE :	
PUNCH HOLE USING HOLLOW AND SOLID PUNCH					TIME	
					CODE NO. F120N1346E1	

Job Sequence

TASK 1: Punch holes using hollow punch

- Cut the rubber sheet to the size of 78x48x2mm.
- Mark the dimensions to locate the hole centres using steel rule and pencil.
- Mark the geometrical shape of gasket as shown in Task 1.
- Draw the circles (holes) and arcs using a compass.
- Mark the geometrical shape of gasket as shown in Task 1.
- Locate the hollow punch cutting edge, to seat on the periphery of the circles marked for holes. (Fig.1)
- Strike on hollow punch to cut the holes using a ball pein hammer.
- Cut the periphery of the gasket using scissors.
- Check for the correctness of dimensions.

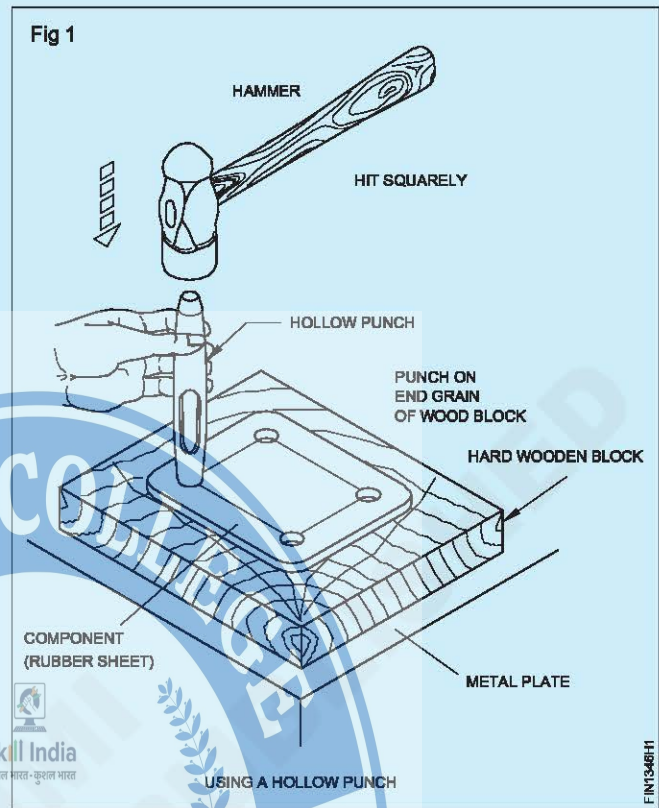

TASK 2: Punch holes using solid punch

- Check the size of the raw material using a steel rule.
- File the burrs on the cut edges of the sheet metal workpiece by a flat file smooth 250 mm.
- Flatten the job material on a Tinman's anvil using a wooden mallet $\varnothing 75$.
- Check the flatness of the job material by a try-square.
- Mark straight lines with a scribe using a steel rule.
- Mark bend lines $a'a'$, $b'b'$, $c'c'$, $d'd'$ on both sides of the workpiece, reducing for face A and E one time thickness of sheet and face B, C and D, 2 time thickness of sheet from the clamp dimensions as shown in Fig 1.
- Mark points 'X' and 'Y' and indent with center punch and ball pein hammer. Mark curved lines using wing divider. (Fig 1)
- Cut along straight and curved lines by straight snips.
- File the burrs on the cut edges of the job by flat file smooth 250 mm.
- Clamp the face B of the job the folding line just above 1/2 time thickness of sheet in folding bars, hold in bench vice and fold the face A at right angles using the wooden mallet $\varnothing 75$. (Fig 2&3)
- Remove the job, by loosening the jaws of the vice.
- Similarly, clamp face D of the job in folding bars held in bench vice and fold face E at right angle using the wooden mallet $\varnothing 75$. (Fig 4)

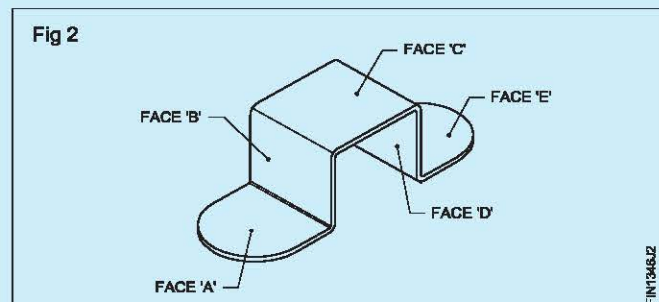
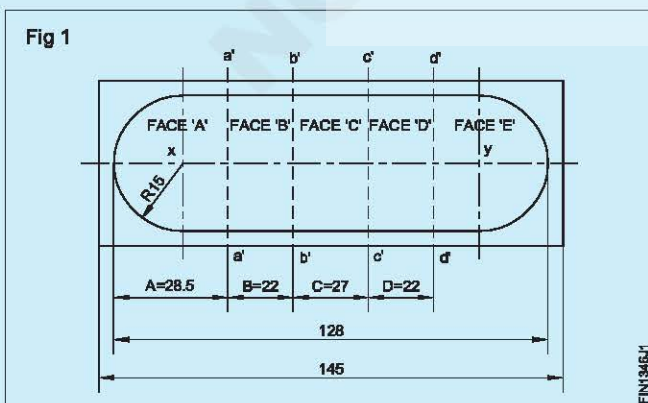

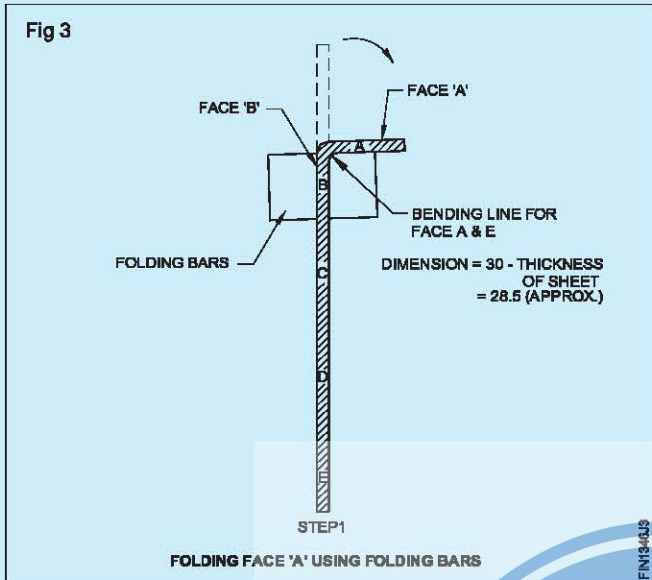

- Remove the job, by loosening the jaws of the bench vice.
- Similarly, clamp face 'C' of the job in angle irons held in bench vice and fold face 'D' at right angle using the wooden mallet $\varnothing 75$ (Fig 6)

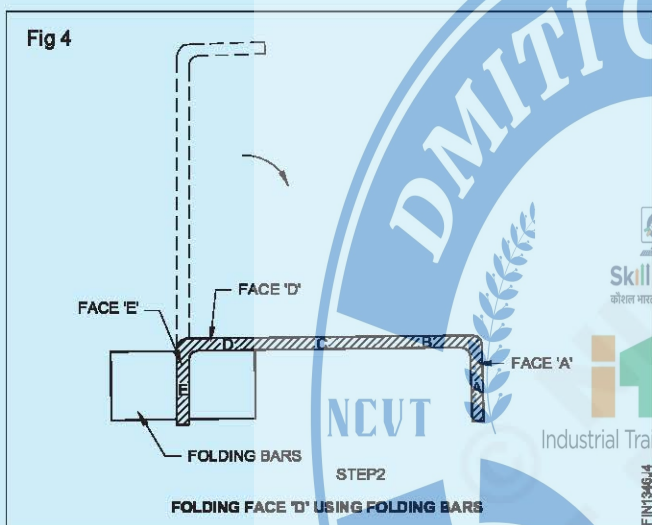
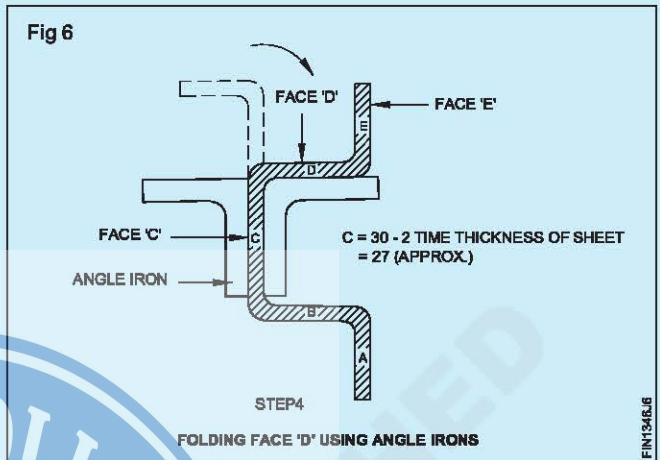

- Check the perpendicularity of all the bends using a try-square.
- Rectify the perpendicularity, using a wooden mallet and a suitable wooden support, if folds are not perpendicular.
- Mark locating points with a scribe and punch using a dot punch and a ball pein hammer. (Fig.7)

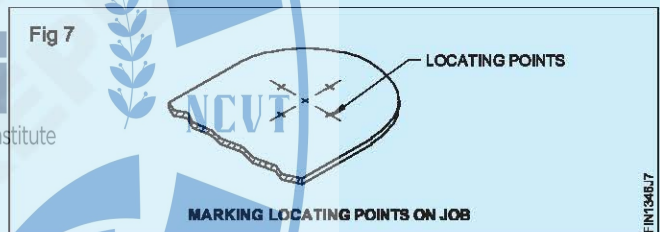

- Remove the job, by loosening the jaws of the vice.
- Clamp face C of the job in a pair of angle irons, held in bench vice and fold face B at right angle using the wooden mallet $\varnothing 75$. (Fig 5)

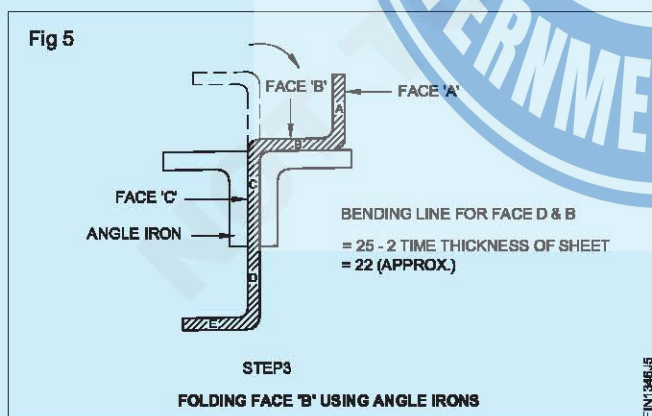

- Place the job over a lead cake.
- Hold the solid punch $\varnothing 6\text{mm}$ on the located points in vertical position by one hand.
- Strike the head of the solid punch with the ball pein hammer by other hand, with sufficient striking force.
- Repeat striking the hammer, till you get the hole.
- File the burr on both sides of the job, using a smooth round file.
- Planish the punched area of sheet on a tinman's anvil for flatness.

Skill Sequence

Positioning the punch and finishing the punch holes

Objectives: This shall help you to

- position the centre of the punch hole
- planish the bulging of punched hole.

Punching is an operation of producing holes on a thin section material using a punch.

Hold the solid punch in vertical position on locating marks on the workpiece by one hand and strike the head of the punch by ball pein hammer in other hand till you get the hole. (Fig 1)

Position the punch such that the four locating points, coincides with the circular cutting edges of the punch, otherwise the centre of the punched hole will get displaced.

Use a lead cake or a cross grained wooden block as a supporting base.

While striking, watch the cutting point and not the head of the punch.

While striking the hammer, ensure that, the hammer strikes at the centre of its bottom face and top face of the punch. Otherwise, the position of the punch gets disturbed and oblong hole is produced. Sometimes, the punch may slip off from its position and cause accident.

While using wooden block as the supporting base, the sheet should be placed at gross grained end of the wood, otherwise, distortion is caused. (Fig 2)

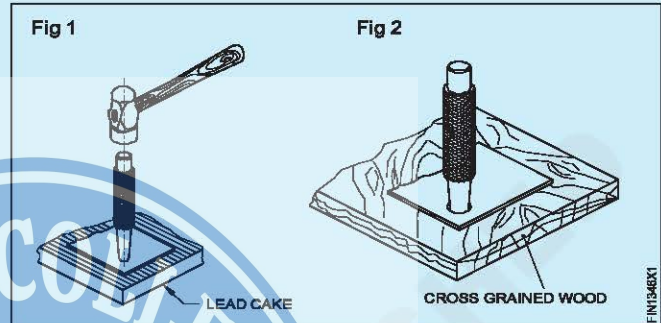

A punched hole diameter reduces slightly, when the sheet is flattened after punching. Finish the punched hole, file the burr, then planish the bulging caused due to punching. (Fig 3)

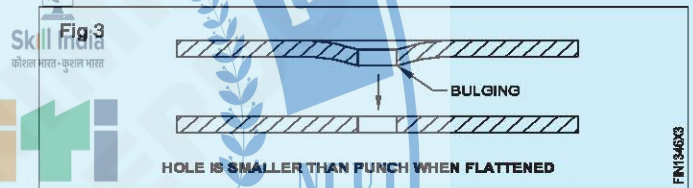

Resharpener of a solid punch

Objective: This shall help you to

- sharpen the blunt cutting edges of a solid punch on a bench grinder and pedestal grinder.

Introduction

After continuous use, the cutting edges of a solid punch gets blunt. In order to get the punch for reuse, the punch is resharpened.

Resharpener is done on a bench or a pedestal grinder. Grinding is done on face and tapered diameter of the solid punch.

Before grinding, ensure that the grinding wheel is properly dressed and the wheel is true.

Ensure that the gap between the grinding wheel face and the tool rest is approximately 2 mm.

Hold the solid punch on the tool rest, perpendicular to the face of the grinding wheel. (Fig 1)

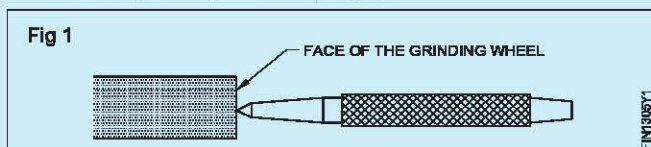

Grind the face of the punch slowly by rotating it in clockwise direction.

While rotating, hold the punch rigidly on the tool rest and see that excessive force is not applied while grinding.

Continue grinding till the face of the punch becomes flat.

Now hold the punch at an angle as shown in Fig 2 and grind slowly the diameter of the solid punch by rotating the punch clockwise. While grinding see that the punch is held tangential and the diameter of the punch is just touching with light force to the face of the grinding wheel. Rotate the punch uniformly for proper grinding of the diameter.

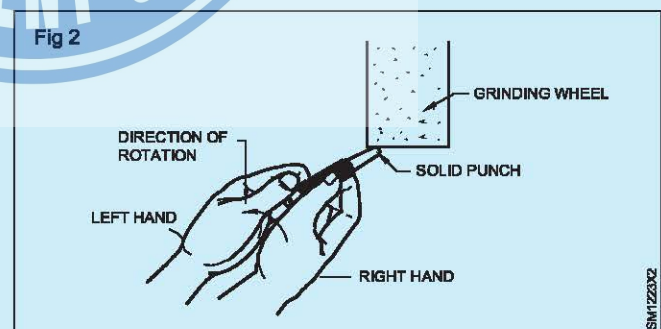

Don't use sides of grinding wheel for grinding diameter or face of the punch.

Don't apply excess pressure while grinding, otherwise it will damage the punch or even it may cause accident.

Do lap and butt joints

Objectives: At the end of this exercise you shall be able to

- set and tack lap joint in correct alignment
- solder a lap joint, in flat position using soft solder
- solder a fillet and butt joint in flat position using electric soldering iron.

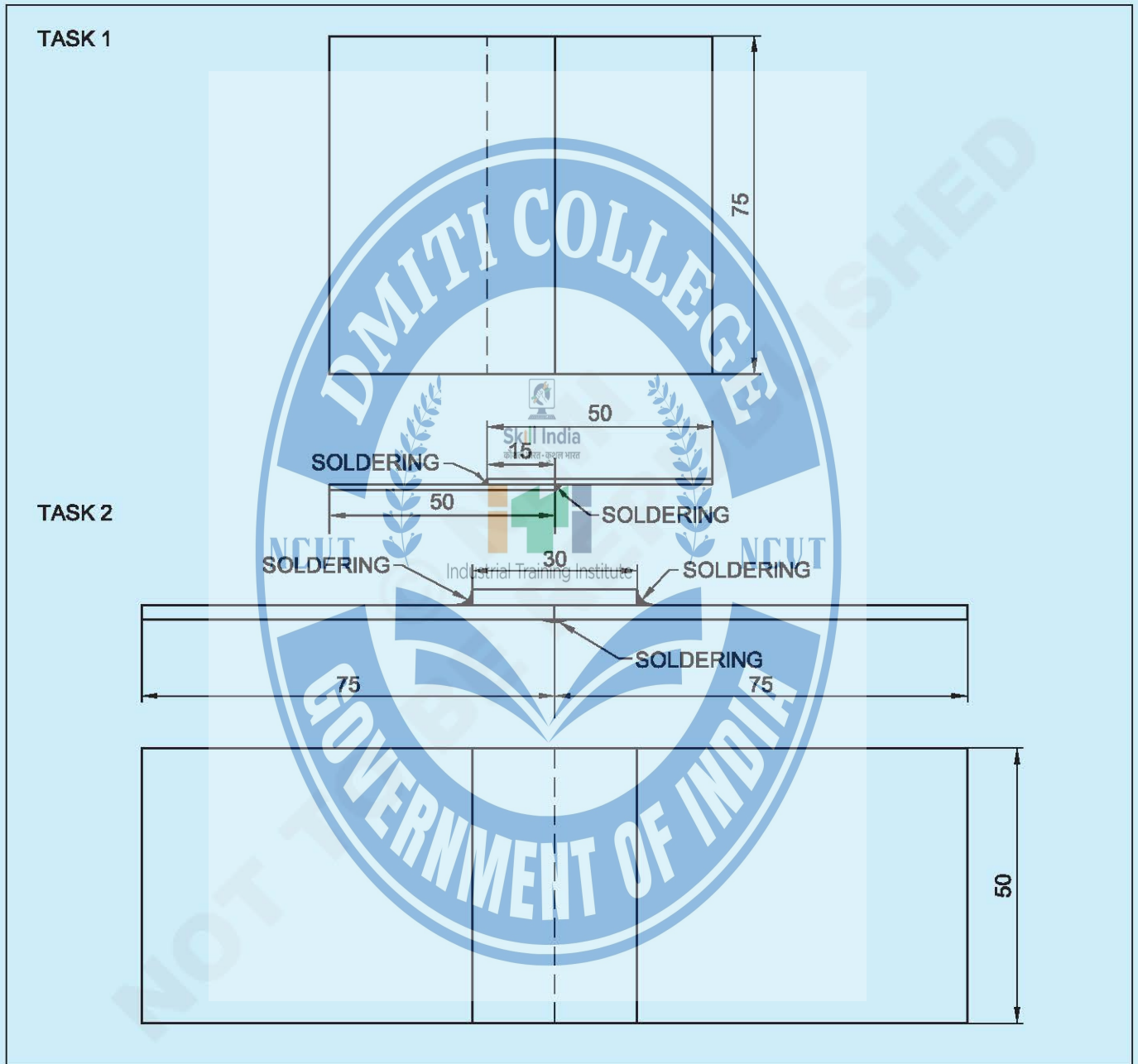

1	ISSH 50 x 30 X 0.6	-	TINNED SHEET	-	TASK-2	1.3.47
2	ISSH 75 x 50 X 0.6	-	TINNED SHEET	-	TASK-2	1.3.47
2	ISSH 75 x 50 X 0.6	-	G.I SHEET	-	TASK-1	1.3.47
NO.OFF	STOCK SIZE	SEMI-PRODUCT	MATERIAL	PROJECT NO.	PART NO.	EX. NO.
SCALE 1:1		SOLDERING LAP JOINT AND BUTT JOINT			DEVIATIONS ±0.5	TIME 15h
					CODE NO. FIN1347E1	

Job Sequence

TASK 1: Soldering lap joint

- Cut two pieces of sheet metal to the size 75x50x0.5mm.
- Check the size of the material using a steel rule and squareness with a try square.
- Place two pieces one over the other as shown in job drawing. Prepare the portable hand forge with charcoal and fire with blower.

- Heat the soldering copper bit and tin the working point of it.
- Tack and solder the joint.
- Clean the joint using water to remove the oxides.

TASK 2: Soldering butt joint

- Cut the material in three pieces as per the job drawing.

- Make the single plated butt joint using an electric soldering iron as per the job drawing.
- Clean the job using water to remove the oxides.

Skill Sequence

Method of soft soldering

Objective: This shall help you to

- **make a joint by soft soldering.**

Soft soldering

Clean the area to be joined thoroughly

Where a lap joint is required on mild steel, both sides of the top lap should be cleaned and tinned, to assist heat transfer when soldering.

Heat the copper of the soldering iron until the flame is bright green. Keep the edge of the copper bit upward. (Fig. 1)

Fig 1

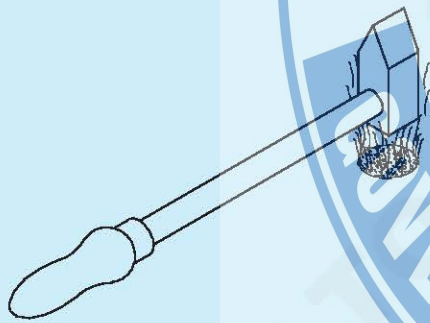

Dip the edge of the bit in flux solder-acid. (Fig.2)

Fig 2

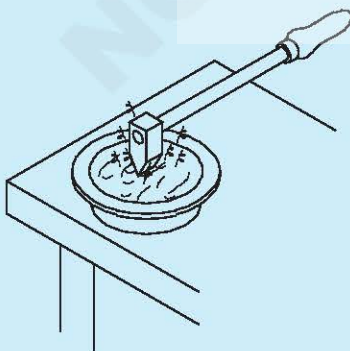

The tip is tinned by rubbing it along the solder. (Fig.3)

Fig 3

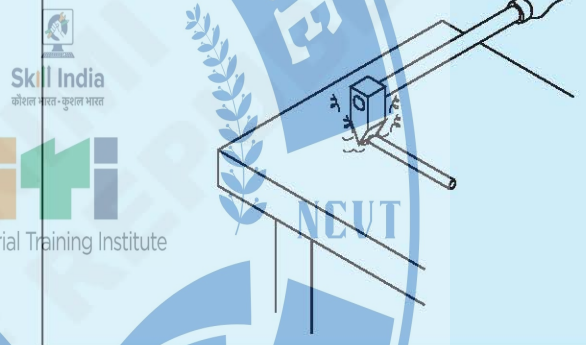

Place the sheet on a soldering bench.

Apply the flux on the area to be joined. (Fig.4)

Fig 4

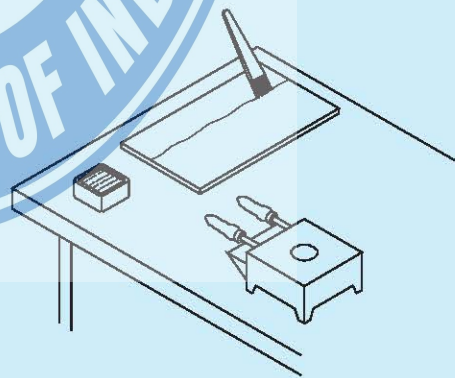

Dip the point into the flux. This will remove the oxide film from the finned faces.

Apply the solder to the point. (Fig.5)

Apply the bit to the work.

Spread the solder evenly on the surfaces.

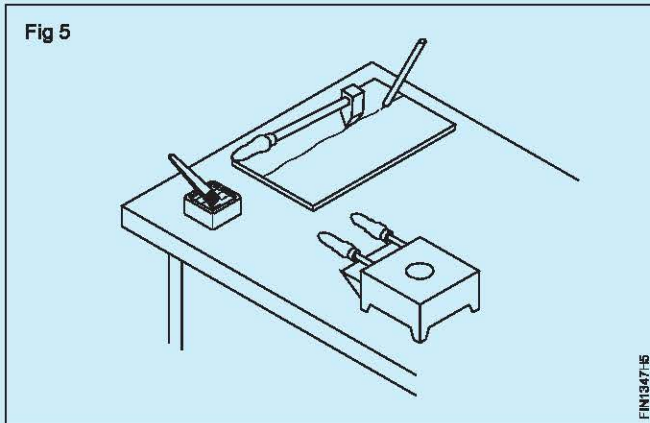

Keep the tinned face of the bit flat, to obtain maximum heat transfer.

Apply more solder as required.

Turn the sheet over and tin the other lap area in the same manner.

Using a wet rag, clean off the excess flux.

Making a single plated soldered butt joint

Objectives: This shall help you to

- set and tack single plated butt joint in correct alignment using electric soldering iron
- solder a fillet and butt joint of correct size in flat position using electric soldering iron.

Check the size of three sheet metal pieces by using a steel rule.

Select a suitable type of an electric soldering iron.

Check if it has loose components, connections, frayed or damaged insulation. If found, replace the soldering iron. Short circuiting because of the above faults may cause shocks and fires. (Fig 1)

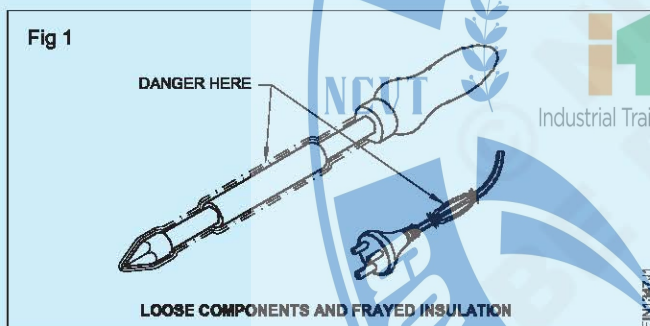

Do not attempt yourself to repair it. Repairs should be carried out by a qualified electrician.

Plug it in the socket of the switch board and switch 'ON'. Place the electric soldering iron on a suitable support stand. (Fig 2)

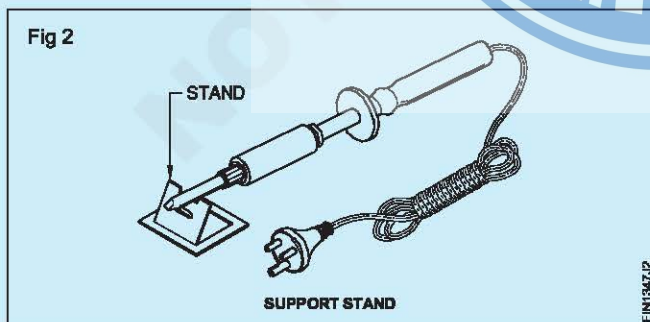

Select the suitable flux for the job.

Select the suitable solder for the job.

Clean the surface to be joined.

Apply the flux to the joint by using a brush.

Layout three sheet metal pieces to obtain single plated butt joint as per the job drawing.

Place the electrical soldering iron such that its lead does not come across sharp edges of the metal pieces. (Fig 3)

Tin the point of electric soldering iron by rubbing it on a soft solder.

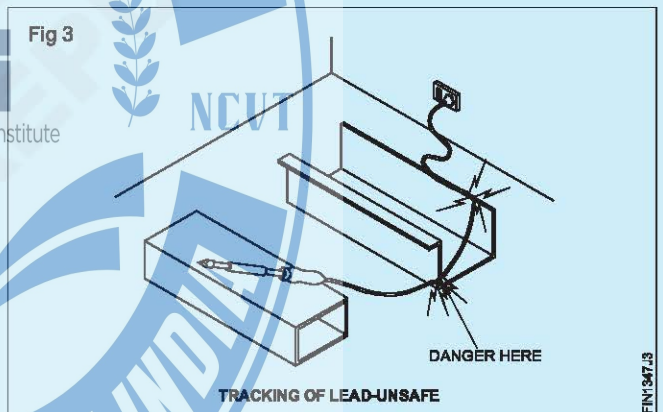

Tinning on the bit should be bright and should cover the faces of the tip completely.

Set and tack the three metal pieces in correct alignment.

Solder the butt edge at the bottom and cover the plate edges at the top. (Fig 4)

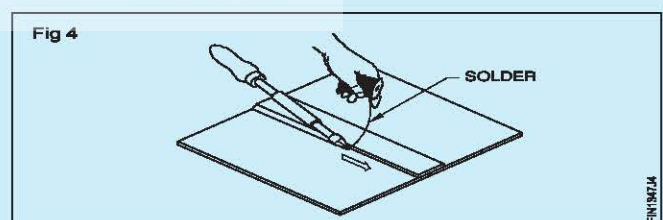

Switch off the power, then remove the plug from the switch board after soldering is completed.

Clean the job in cold water to remove the oxides.

Check the joint and rectify, if required.

Bend sheet metal into various curvature forms - Funnel
Wired edges - Straight and curves, fold sheet metal at angle using stakes

Objectives: At the end of this lesson you shall be able to

- make straight wired edge
- make curved wired edge
- fold sheet metal at angle using.

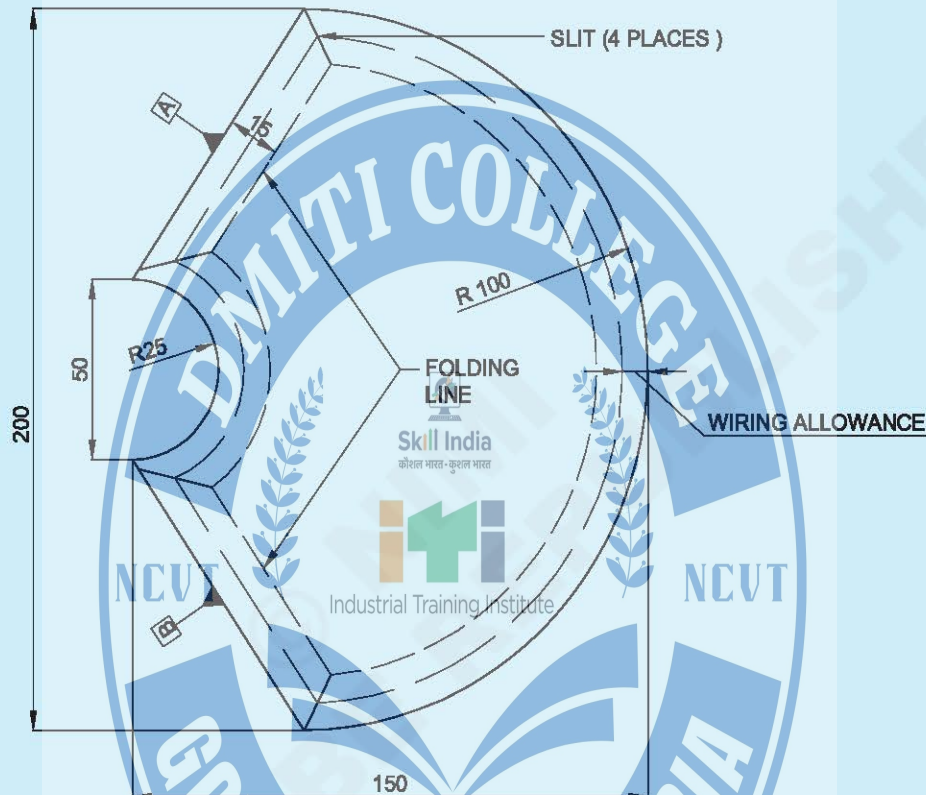

Job Sequence

ISSH 205x155x0.6 G.I-Sheet

- Cut 0.6mm thickness G.I Sheet to the required size as mentioned in the drawing.
- Mark the profile, folding line and wiring allowance as per the drawing.
- Make a slit at 4 places using straight snip.
- Use ϕ 2mm wire and make straight wired edge at side A and B (Follow the procedure mentioned in exercise 1.3.45 for straight wired edge).
- Use ϕ 2mm wire and make curved wired edge at R100 and R25.
- Use hatchet stake and fold the sides A & B to 90° angle.
- Use half moon stake having radius 100 and 25mm for folding to curved shape.

1	ISSH 205 x 155 x 0.6		G.I SHEET			1.3.48
NO.OFF	STOCK SIZE	SEMI-PRODUCT	MATERIAL	PROJECT NO.	PART NO.	EX. NO.
SCALE 1:1	FUNNEL WIRED EDGES-STRAIGHT AND CURVES, FOLD SHEET METAL AT ANGLE USING STAKES				DEVIATIONS ± 0.04	TIME.
					CODE NO. F120N1348E4	

Make simple square container with wired edge and fix handle

Objectives: At the end of this exercise you shall be able to

- develop the pattern for square container
- prepare the square container with lid by knocked up joint and locked grooved joints
- make the cover plate and handles for container
- finish the container with wired joint.

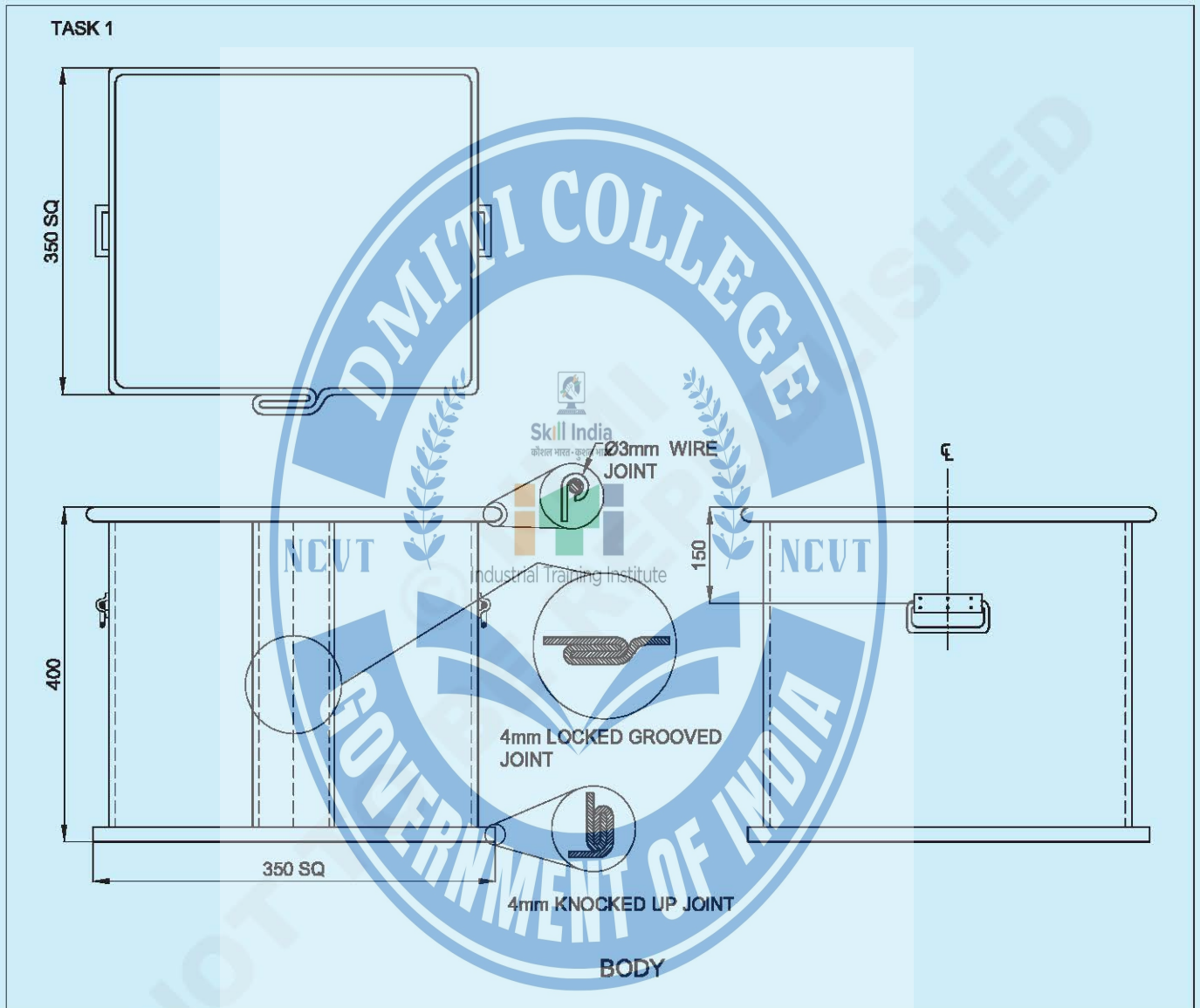

3	Ø6x270mm	-	GI SHEET	-	TASK-4	-
3	ISSH 80x65x0.6	-	GI SHEET	-	TASK-3	-
1	ISSH 370x370x0.6	-	GI SHEET	-	BOTTOM SHEET	-
1	ISSH 400x400x0.6	-	GI SHEET	-	TASK-2	-
1	ISSH 420x420x0.6	-	GI SHEET	-	TASK-1	1.3.49
NO.OFF	STOCK SIZE	SEMI-PRODUCT	MATERIAL	PROJECT NO.	PART NO.	EX. NO.

SCALE 1:1	SQUARE CONTANER	TOLERANCE :	TIME :
		CODE NO. F/20N1349E1	

TASK 2

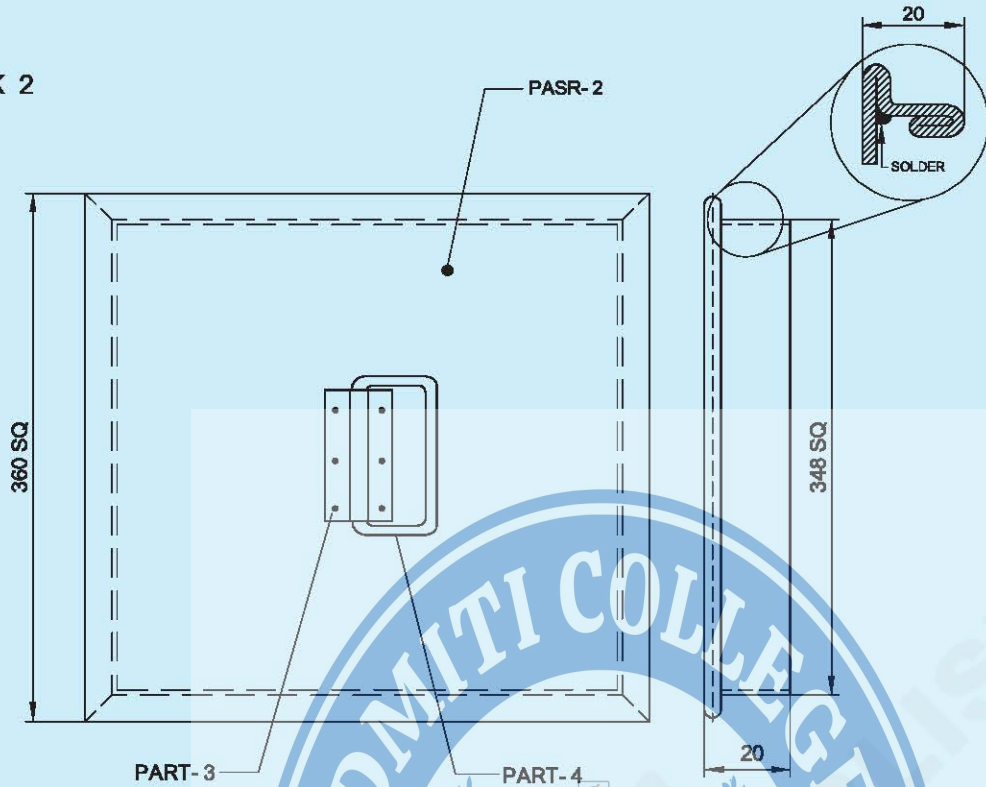

TASK 3

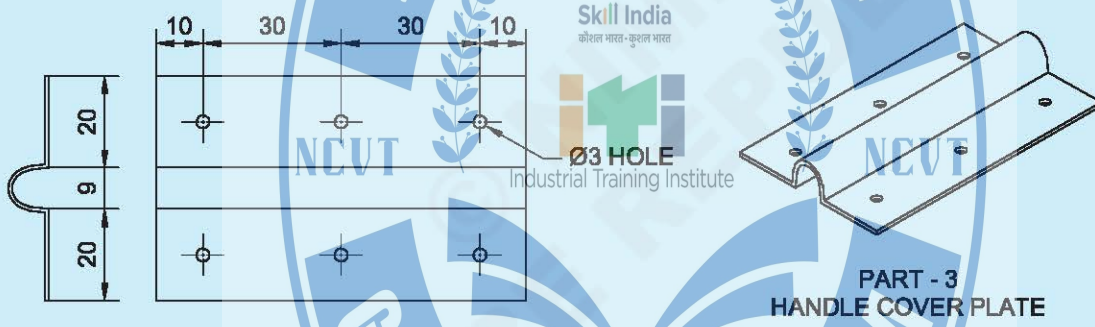

TASK 4

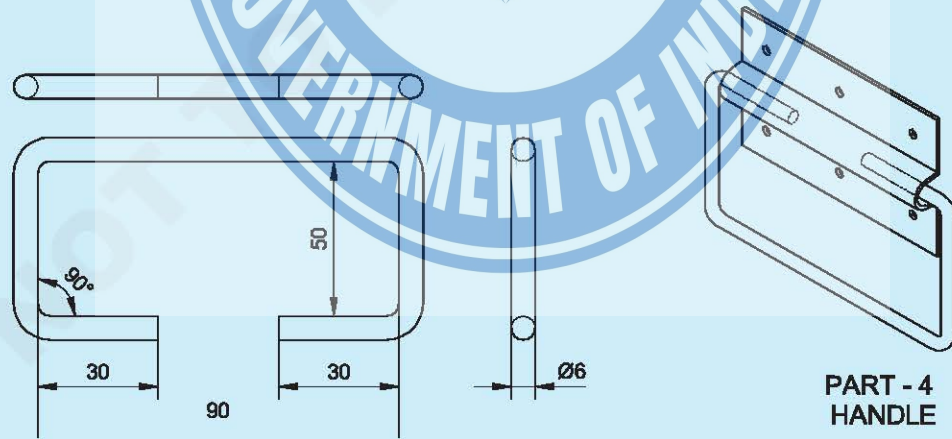

						1.3.48
NO.OFF	STOCK SIZE	SEMI-PRODUCT	MATERIAL	PROJECT NO.	PART NO.	EX. NO.
<p>SCALE 1:1</p> <p>SQUARE CONTAINER</p>					TOLERANCE : ±1mm	TIME :
					CODE NO. F120N1348E2	

Job Sequence

TASK 1: Development of square container body

- Develop and layout the pattern by parallel line method, considering the wiring allowance. Locked grooved joint and knocked up joint for the body and bottom as shown in the fig.1.

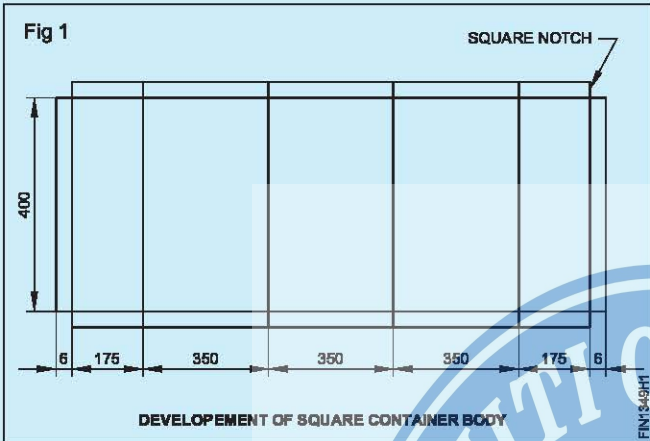

- Cut the layout pattern using scissors for body and bottom.

- Paste the pattern on sheet metal.
- Cut the sheet metal on the outline of layout pattern pasted to the sheet using straight snips.
- Cut straight notch at bend line upto the hemming line at both ends of the body.
- Prepare the hem at bottom of the body to fix bottom sheet and locked grooved joint.
- Prepare the hem to fold as flange for knocked up joint.
- Fold the sheet metal against the angle iron/folding bar/square stakes suitably clamped.
- Strike with wooden mallet, gradually along the bend line.
- Check using a try square/steel square and continue to form the square body of the container.

TASK 2: Development of square container lid

- Develop and layout the pattern by parallel line method, considering the hemming allowance and also fit into the body. (Fig.1)

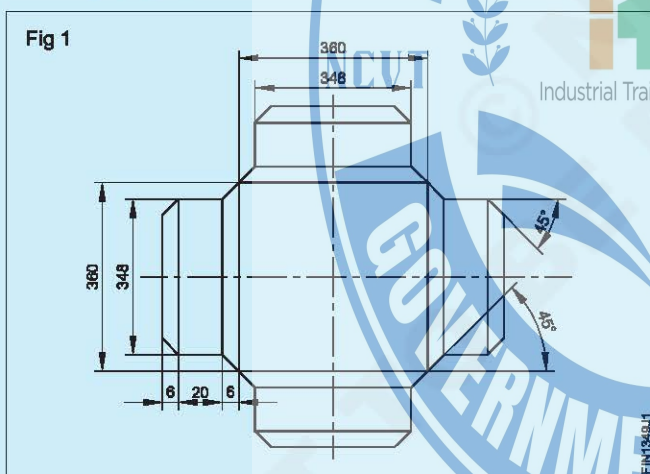

- Cut the layout pattern, square cover using scissors.
- Paste the pattern on sheet metal.
- Cut out the sheet metal on the outline of layout pattern pasted to the sheet using straight snips.
- Cut the notch at 45° in four sides for hemming as shown in figure.
- Bend the hemming on four sides of the cover sheet using square stakes.
- Bend the flange on four sides of the cover sheet using square stakes.
- Solder the four corners using soft solder.

TASK 3: Development of square container bottom sheet

- Develop and layout the pattern by parallel line method, considering the hemming allowance and also to fit into the body as shown in Fig 1.
- Cut the layout pattern of square container bottom sheet using scissors.
- Paste the pattern on sheet metal.
- Cut out the sheet metal on the outline of layout pattern pasted to the sheet using straight snips.
- Cut the square notch all four sides for hemming as shown in figure.

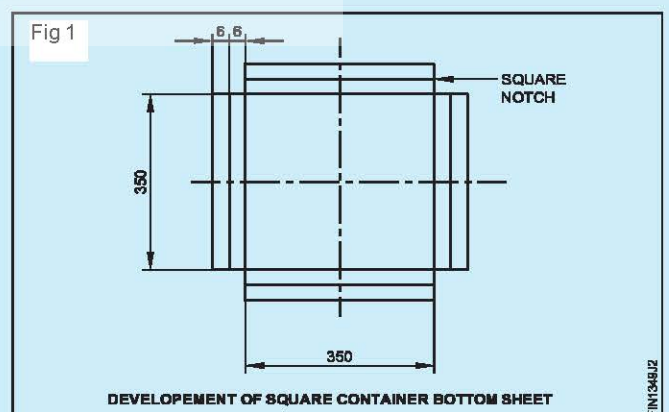

- Prepare the hemming on four sides of the bottom sheet using square stakes, so to make knocked up joint with the body of square container.
- Fix the body of the square container on the bottom sheet to fold seam.
- Fold the four sides of bottom to form the knocked up joint using square stakes.
- Fix the handle cover plate along with front handle 3 Nos
- Complete and finish the as per sketch.
- Ensure the lid is in proper fit against the container body.

Body wired edge

- Place the wire on top of the body edge and form the wired edge on four sides of the body continuously as shown in Job Sequence.
- Finish the wired edge on hatchet stake and cut off the surplus wire at the ends.

Handle fixing

- Prepare handle cover plate as shown in job drawing part 3.
- Prepare front handle as shown in job drawing part 4.
- Fix the handle cover plate along with front handle 3 Nos
- Complete and finish as per job drawing.
- Ensure the lid is in proper fit against the container body.

Skill Sequence

Calculate the length of material for bending

Objectives: This shall help you to

- state the effects due to bending
- calculate the required length of metal for bending.

While bending a rod, sheet or pipe, due to the tensile force in the outer part of the material at the bending point, the material is stretched. (Figs 1 and 2) Due to the force of pressure in the inner part of the material at the bending point, the material is compressed.

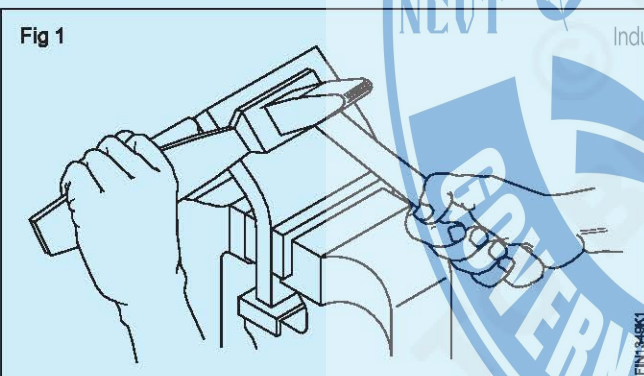

The layer in the middle of the material is not subjected to either tension or compression.

This is called the neutral axis. (Fig.2)

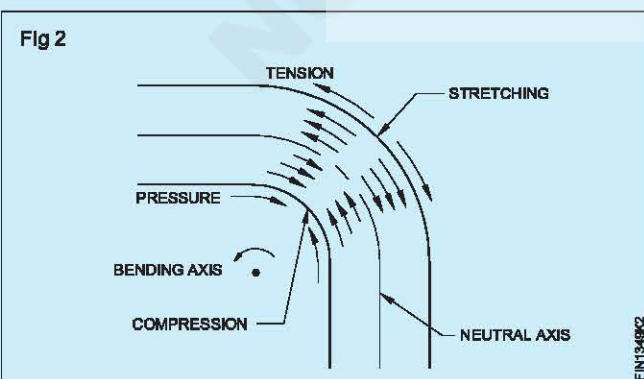

For calculating the length of material for bending, the material length at the neutral axis is taken into account.

The length of the blank/rod/pipe is the stretched length before bending. The stretched length is determined along the neutral axis. For calculating the stretched/elongated length of a rod/sheet/pipe while bending (Fig.3), first add all straight portions together.

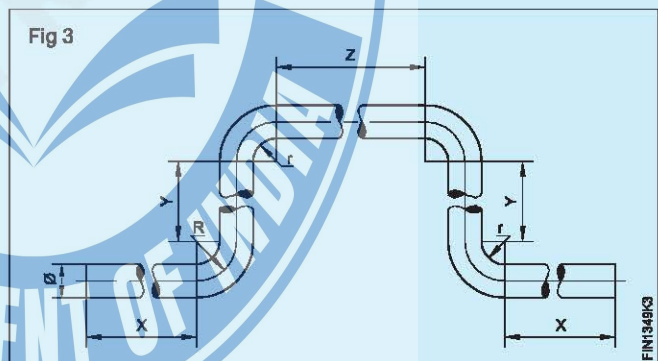

$$x+y+z+y+x=2x+2y+z$$

Then add the bent space distance together. For calculating this: take the radius of the bent up to the neutral axis and also take the angle of the bend into consideration. (Fig.4)

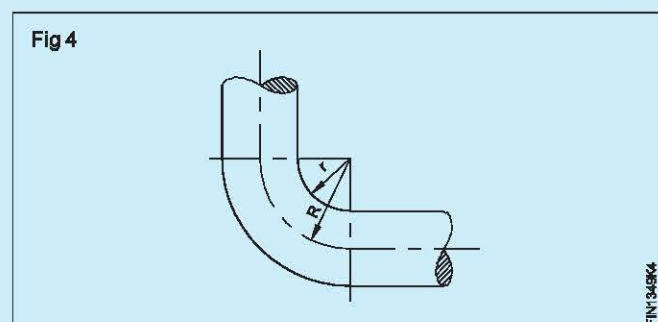

Radius of the bend up to neutral axis

= inner radius+(0.5 x thickness of sheet OR diameter of rod or pipe. Angle of the bend with respect to Figs 3 & 4 is 90°.

Radius of the bend up to neutral axis.

Radius of the bend up to neutral axis=inner radius +(0.5 x thickness of sheet OR diameter of rod or pipe) angle of the

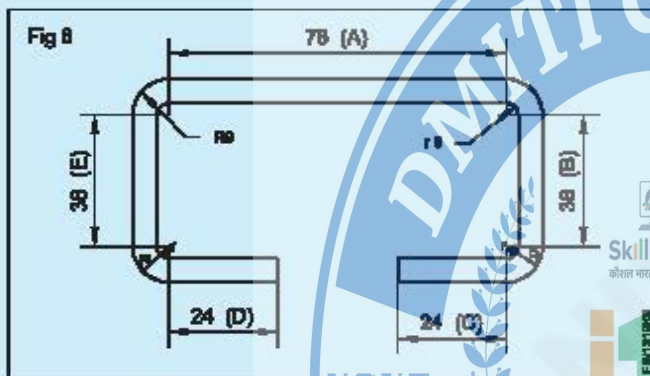
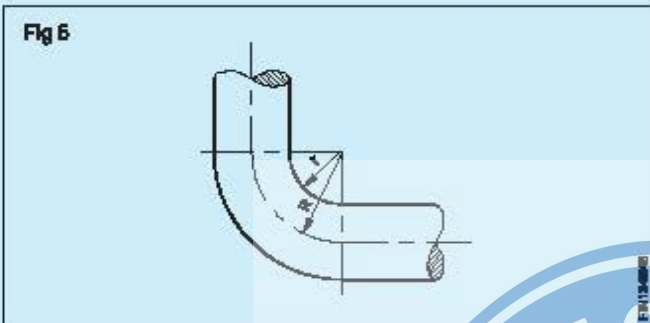

bend with respect to 90°. (Figs 5 & 6)

Radius of the bend up to neutral axis,

=Inner radius +(0.5 x thickness of round rod)

Radius of the bend upto neutral axis,

=6+(0.5x6)mm

6+3.0mm

=9mm

∴ Radius of the bend up to neutral axis =9mm

Length of the curved portion = $\frac{\text{Angle of curve} \times 2\pi R}{360}$

Where 'R' is the radius of curve at the neutral axis.

∴ Stretch length of one bend = $\frac{\text{Angle of curve} \times 2\pi R}{360}$

$$\begin{aligned} \therefore \text{Stretch length of four bends} &= 4 \times \frac{90^\circ}{360^\circ} \times 2\pi \times \frac{22}{7} \times 9\text{mm} \\ &= 56.57\text{mm} \end{aligned}$$

Straight portion length,

For the length of 'A'

$$A = 90-(6+6)\text{mm}$$

$$= 90-12\text{mm}$$

$$= 78\text{mm}$$

For the length of 'B',

$$B = 50-(6+6)\text{mm}$$

$$= 50-12\text{mm}$$

$$= 38\text{mm}$$

Total length

For the length of 'C'

$$C = 30-6\text{mm}$$

$$= 24\text{mm}$$

For the length of 'D'

$$D = 30-6\text{mm}$$

$$= 24\text{mm}$$

For the length of 'E'

$$E = 50-(6+6)\text{mm}$$

$$= 50-12\text{mm}$$

$$= 38\text{mm}$$

Total length of the $\varnothing 6\text{mm}$ round rod=length of A+B+C+D+E+stretch length of four bends.

$$= 78+38+24+24+38+56.57\text{mm}$$

$$= 258.57\text{mm}$$

Total length of the round rod = 258.57mm.

Front handles

Calculate the length of the round rod to make front handles 3 Nos. as shown in the figures.

Mark the length of rod required as per calculation.

Cut the length rod using hack saw. (Fig 7)

File the ends of rounded rod to remove the burrs.

Mark the dimension for bending length. (Fig 8)

Set the round rod in bending fixture.

Instructor to arrange suitable bending fixture

Bend the round rod to form 90° (Fig 9)

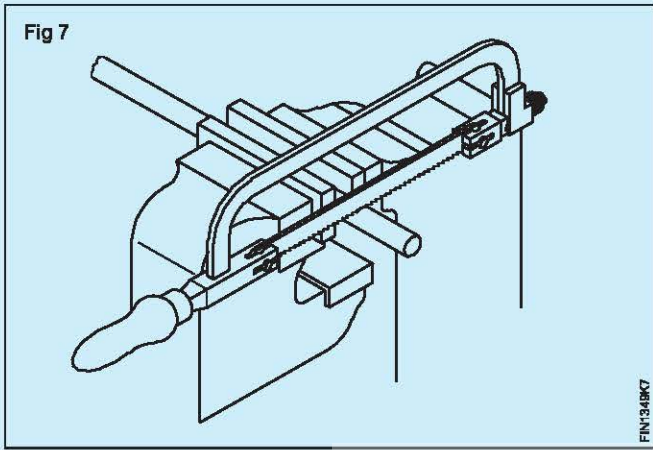

Set the round rod to 50mm from the bent leg to 90°.
Bend the round rod to 50mm as per shown in Fig.11.

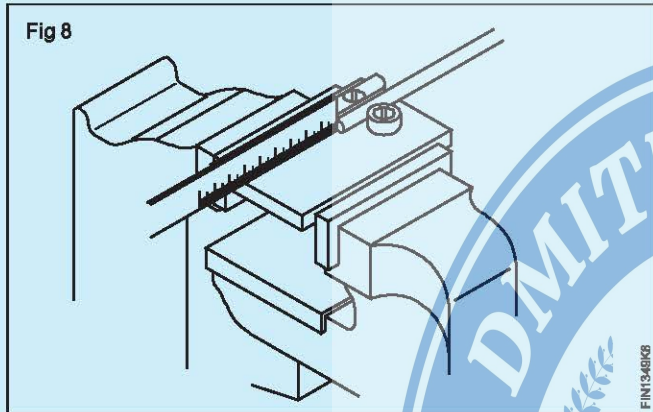
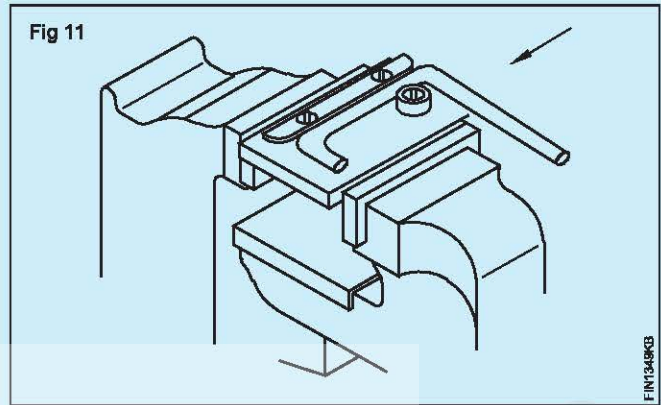

Set the round rod to 90mm from the bent leg to 90°.
Bend the round rod to 90mm as per shown in the fig 12.

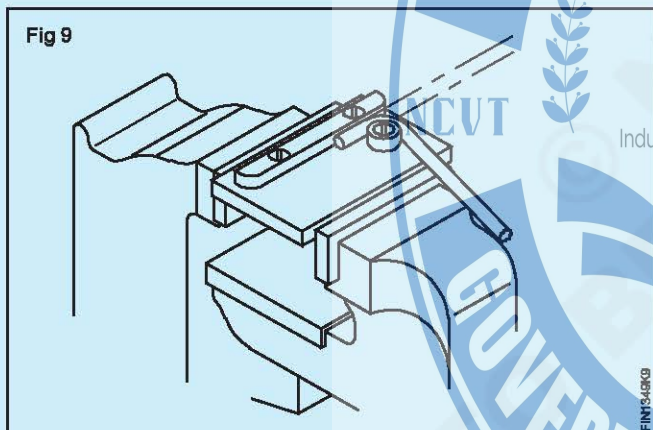
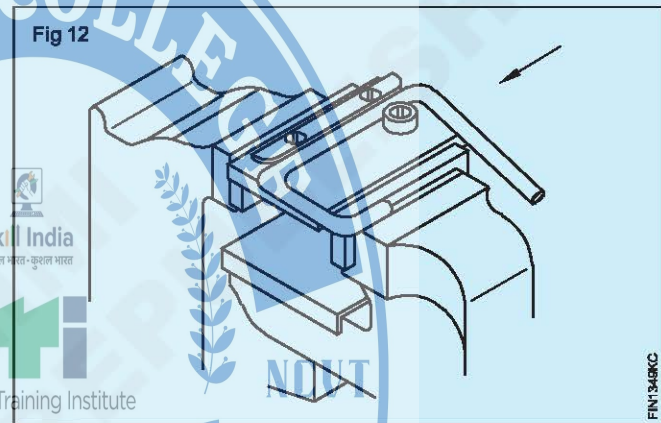

Set the round rod to 50mm from the bent leg to 90°.
Bend the round rod to 50mm as per shown in the figure.
(Fig.13)

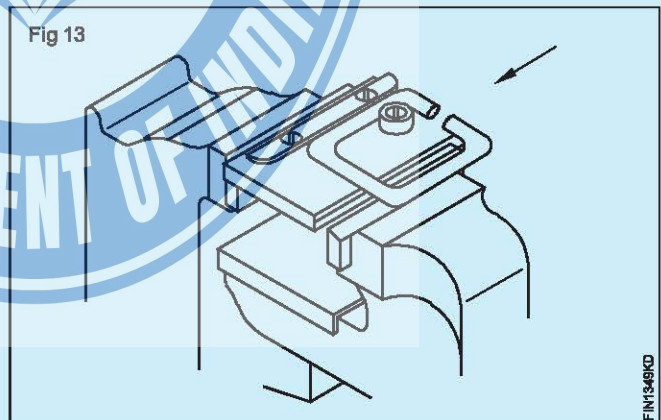

Check the bent angle 90° using bevel protractor. (Fig 10)

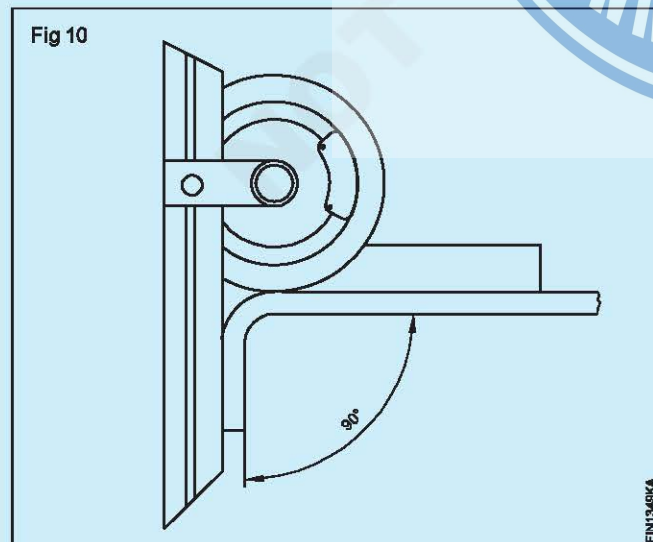

Check the dimension of front handle using steel rule.
(Fig.14)

Similarly, complete the remaining two front handles following the above job sequences.

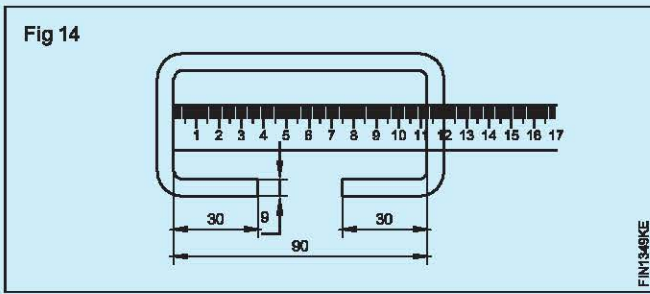

Handle cover plate

Calculate the length and width required to make the handle cover plate.

Mark centres of holes as per job drawing.

Cut the sheet using straight snip.

Deburr the edge.

Form 'U' groove in the middle of the sheet using suitable roundrod.

Drill $\varnothing 3$ mm hole on the centres as shown in fig.15

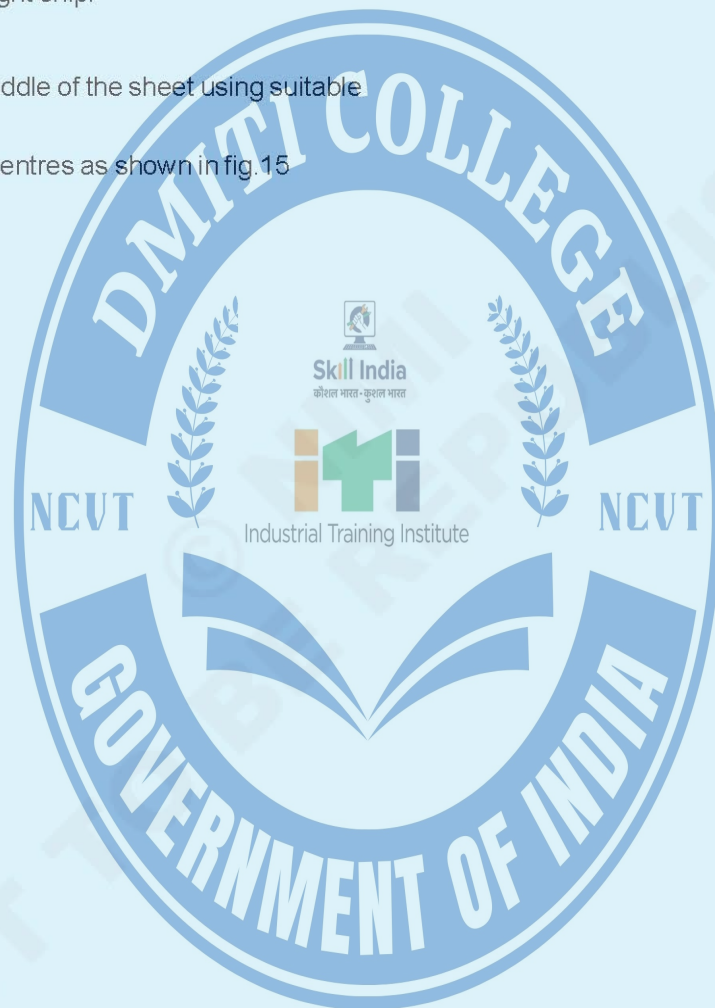
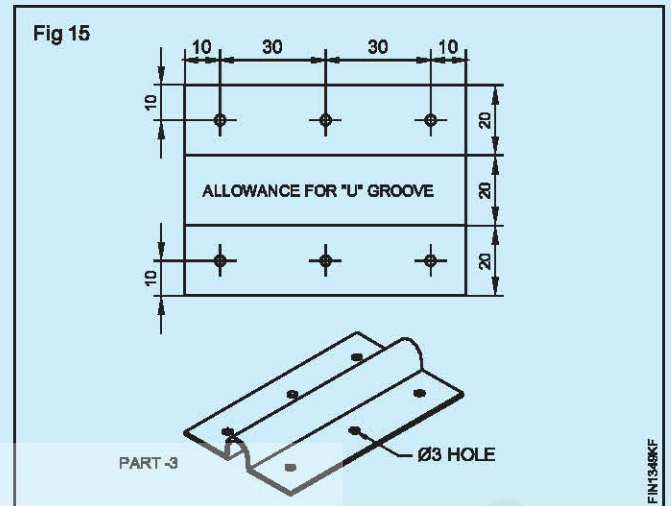

Make square tray with square soldered corners

Objectives: At the end of this exercise you shall be able to

- develop layout the pattern of square taper tray
- make a single hem on the edges using folder bar
- fold the sides of taper tray at 60° using pair of angle iron
- solder the four corner of square taper tray.

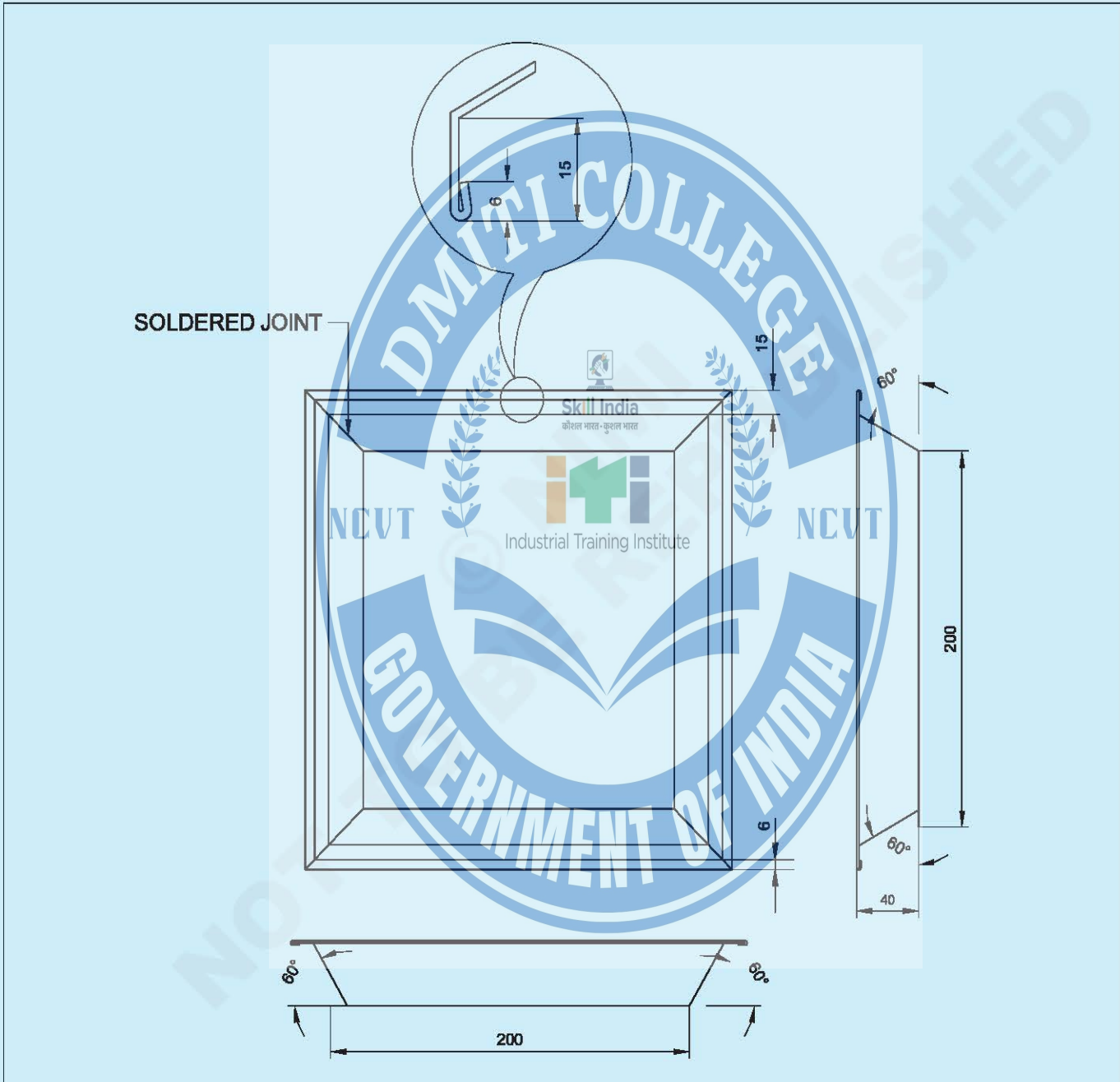

1	ISSH 350 x 350 x 0.61	-	G.I SHEET	-	-	1.3.50
NO.OFF	STOCK SIZE	SEMI-PRODUCT	MATERIAL	PROJECT NO.	PART NO.	EX. NO.
SCALE 1:1	TITLE ; SQUARE TAPER TRAY				DEVIATIONS ±1	TIME :
					CODE NO. F120N1350E1	

Job Sequence

- Check the size of the sheet metal as per job drawing using a steel rule.
- Flatten the sheet metal piece on the dressing plate using a wooden mallet.
- Develop and layout the pattern for the tray, considering allowance for the flanges and single hem, on sheet metal by geometrical construction method using a scribe, steel rule, protractor and divider. (Fig.1)
- Cut the sheet metal as per the pattern layout on the sheet metal using a straight snip.
- Fold 6mm edges to make single hems on the four sides on the barfolder.
- Fold 15mm sides at 60° to make flanges on the four sides of the taper tray on the barfolder.
- Fold 46mm four sides, at 60° as shown in the job drawing, using a pair of angle iron, a benchvice, a 'C' clamp and a wooden mallet.
- Check the angle of the tapered sides using a bevel protractor and rectify, if necessary.
- Solder four corners of square tray.

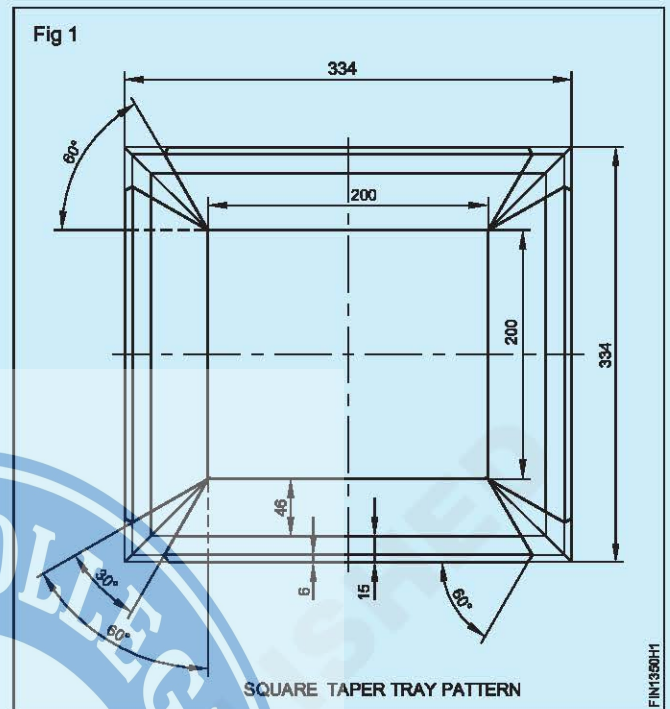

Skill Sequence

Preparing the pattern layout

Objectives: This shall help you to

- calculate the developed length and width for square taper tray
- develop the pattern layout.

Let us take the same job for better illustration.

Calculate the developed dimension of a square taper tray.

Given

Side of square 200mm

Flange length = 15mm

Let us take the single hem as 6mm and calculate the slant height.

AB is the slant length.

Given AC=40mm (Fig. 1)

$$\sin 60^\circ = AC/AB$$

$$0.866 = AC/AB$$

$$AB = 40/0.866$$

$$AB = 46.18\text{mm}$$

Developed size = Side length of square + 2(slant height + flange length + single hem allowance)

$$= 200 + 2(46 + 15 + 6)$$

$$= 200 + 2(67)$$

$$200 + 134$$

$$= 334\text{mm}$$

Mark and cut the sheet metal to the size square 334mm. (Fig.2)

Draw the centre line of length and width XX and YY respectively. (Fig.3)

Draw the base length and width at the centre of the sheet metal workpiece, marking lines at 100mm on both sides of YY and 100mm on both sides of XX. (Fig.3)

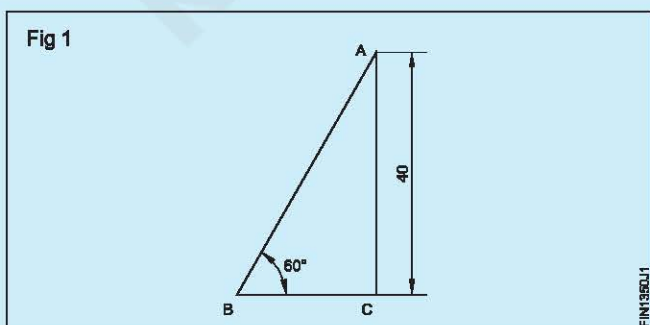

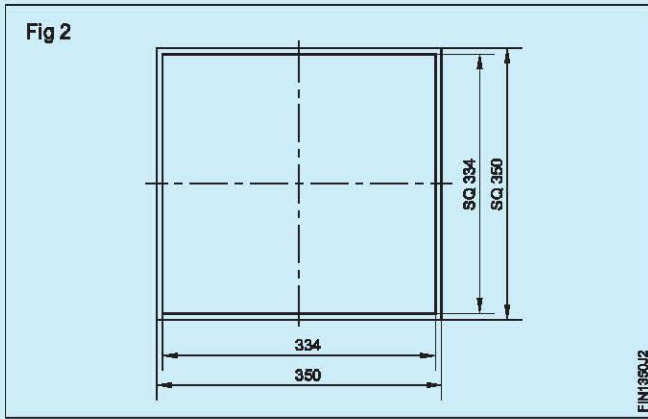

Draw lines for 15mm flange and 6mm single hem allowance on the four sides parallel to EF, FG, GH and HE as shown in the Fig.5.

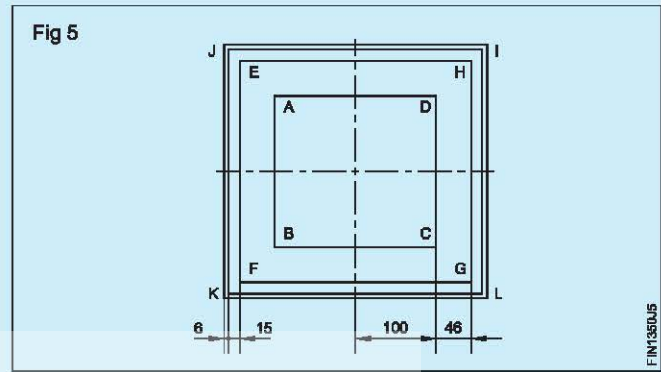

Draw lines at an angle of 30° at points A, B, C, D at both ends of lines AB, BC, CD and DA as shown in Fig.6.

Draw lines at an angle of 60° at points I, J, K, L, M, N, O, P as shown in Fig.6

Cut the unwanted portion of the pattern shown by shadow in Fig.6.

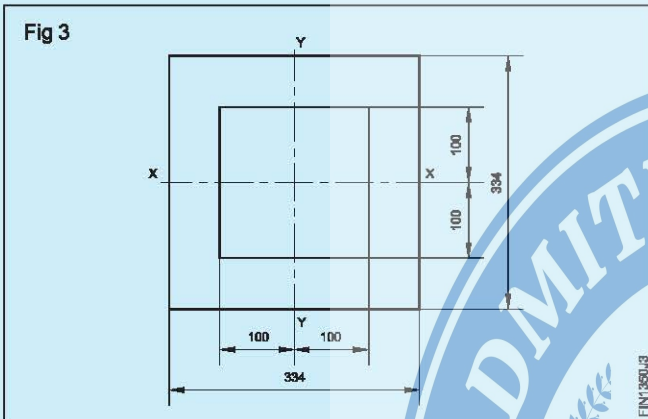

Draw lines for 46mm slant height of the four sides of square taper tray parallel to AB, BC, CD and DA shown in the Fig.4.

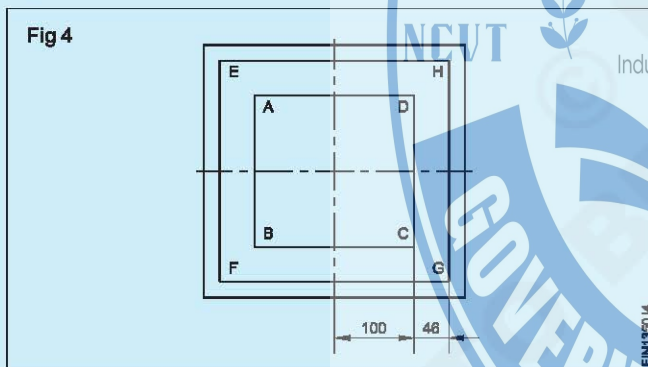
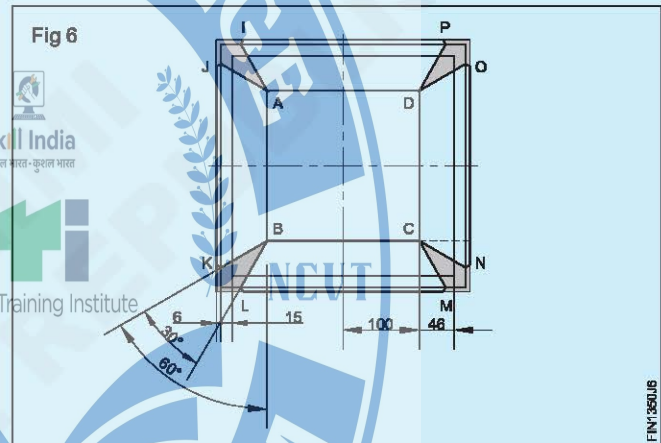

Practice on soft soldering and silver soldering

- Objectives:** At the end of this exercise you shall be able to
- heat the copper bit of soldering iron using blow lamp
 - set and tack a sunk lap joint in correct alignment
 - solder a sunk lap fillet of correct size in flat position
 - prepare the copper tube joints with bell mouth
 - solder with silver brazing rod.

TASK-1

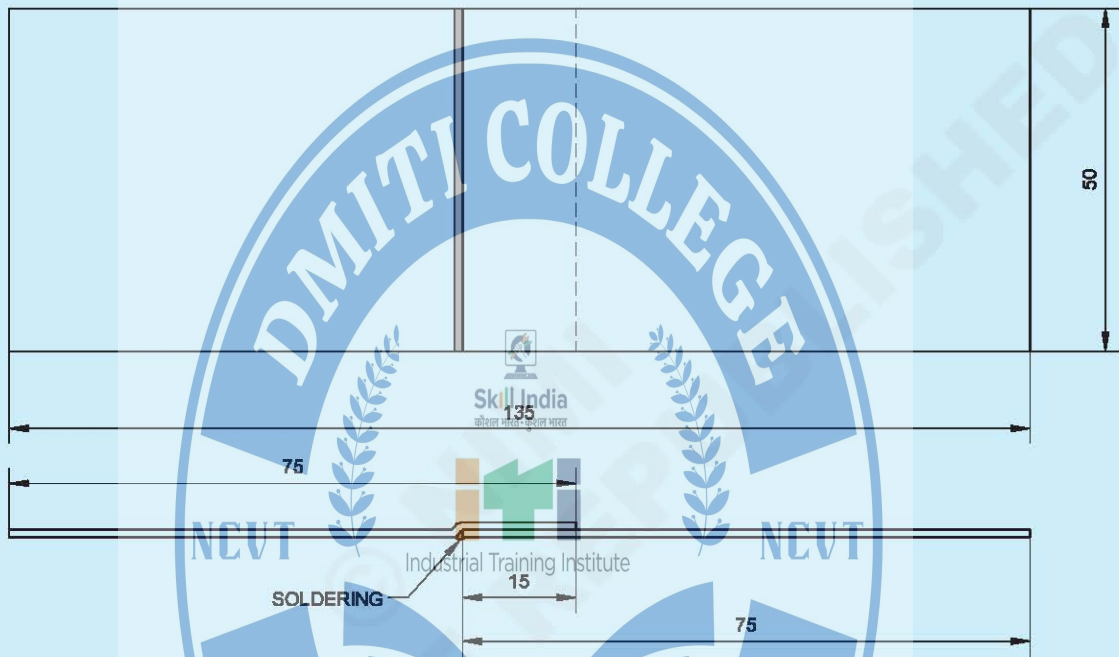

TASK-2

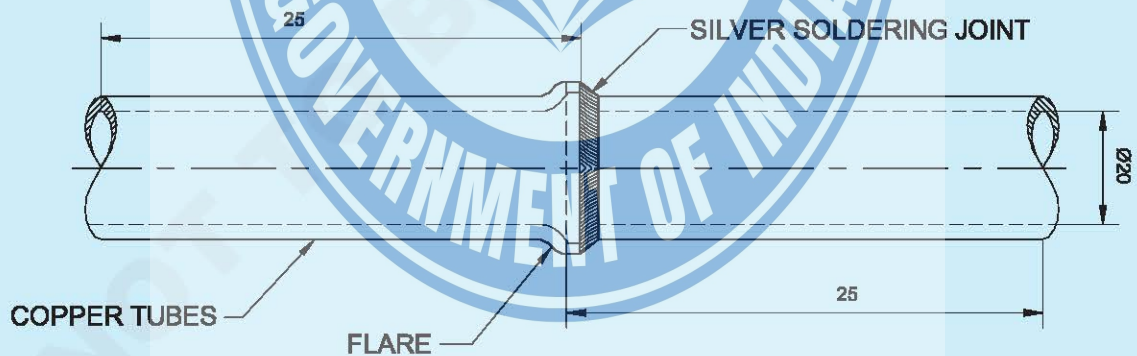

1	Ø1.6 x 1 m	-	SILVER BRAZING FILLER ROD	-	-	-
2	IS 2378 - Ø20 x 1 - 25	-	CUDPA-0	-	-	-
1	-	-	SOFT SOLDER 60:40	-	-	-
1	ISSH 170 x 55 x 0.5mm	-	G.I SHEET	-	-	1.3.51
NO.OFF	STOCK SIZE	SEMI-PRODUCT	MATERIAL	PROJECT NO.	PART NO.	EX. NO.

SCALE 1:1

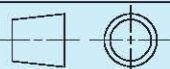

SOLDERED SUNK LAP JOINT

DEVIATIONS ±0.4

TIME :

CODE NO. F120N1351E1

Job Sequence

TASK 1: Sunk lap joint

- Check the size of the material.
- Make the sunk lap joint by using hatchet stake, a wooden mallet and a setting hammer.
- Light the blow lamp.
- Heat the copper bit using a blow lamp.
- Solder the joint.
- Wash the job using water to remove the oxides.

TASK 2: Silver soldering

- Obtain the pipe pieces as per drawing and clean them.

Ensure the use of all safety devices.

- Make a bell-mouth (Flare) at one end of the pipe and insert the other pipe in.

Ensure the fitting of pipes is in alignment.

- Apply silver brazing flux along the root of the joint.
- Hold the joint in a vertical position in a bench-vice on a welding table.
- Set the gas welding plant with a small size nozzle.

- Adjust the soft carburising flame.

Ensure that the length of the feather is 1.5 times the length of the cone.

- Slightly pre-heat around the joint.

Colour change is restricted to dull red.

- Melt and spread the filler rod around the joint with the use of the flux.
- Apply the flame gently around the joint to make the filler metal penetrate in the joint.

Never apply a direct flame on the molten metal.

- Add more filler rods around the joint, if needed.
- Allow the joint to cool for a few seconds.
- Clean the joint and inspect.
- Repeat the same until you are able to make well-penetrated smooth silver-brazed weld.

Avoid overheating the joint.

Skill Sequence

Lighting the blow lamp safely

Objective: This shall help you to

- heat the soldering iron using a blow lamp.

Blow lamp (Fig 1)

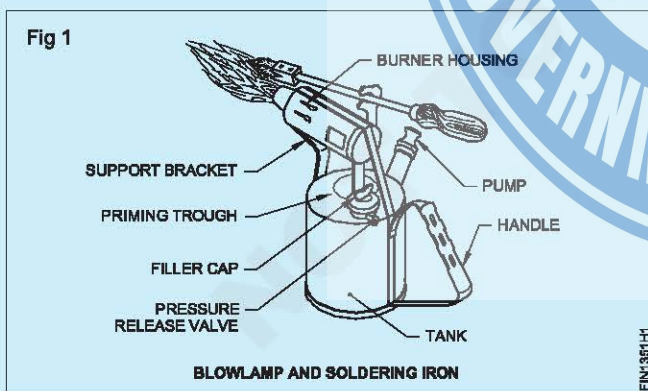

Check the level of kerosene in the tank. Refill if necessary. Make the tank 3/4th full for safety.

Clean the jet with pricker.

Close the pressure relief valve.

Fill the priming trough with methylated spirit.

Take care not to overfill the spirit to avoid fire hazards.

Give two to three strokes to pump for priming the lamp.

Light the spirit.

Operate the pump about six to eight times to pressurize the tank after the spirit gets burnt.

If the liquid kerosene is emitted from the jet at this stage, quickly open the pressure relief valve.

Recommence the starting procedure.

Light the lamp at the top of burner housing.

Activate the pump during use, to maintain constant flame.

If the lamp is blown out by wind or extinguished, open the pressure relief valve immediately. This prevents the inflammable kerosene vapour from escaping in the air.

Do not direct the flame at flammable material.

After the work is over, extinguish the flame by pressure relief valve.

Forming and soldering the sunk lap joint

- Objectives:** This shall help you to
- form a sunk lap using a hatchet stake
 - solder the sunk lap joint.

Check the size, cut if required, and mark the allowance for sunk lap.

Sunk lap using the hatchet stake as shown in Fig 1.

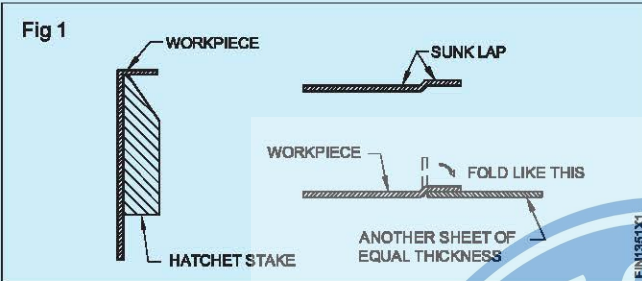

Clean the surface to be joined by an emery paper. Apply suitable flux and place two pieces as shown in Fig 2.



Heat the copper bit using a blow lamp.

Solder the sunk lap joint with uniform flow and proper penetration. (Fig3).

Clean the job with wet rag.

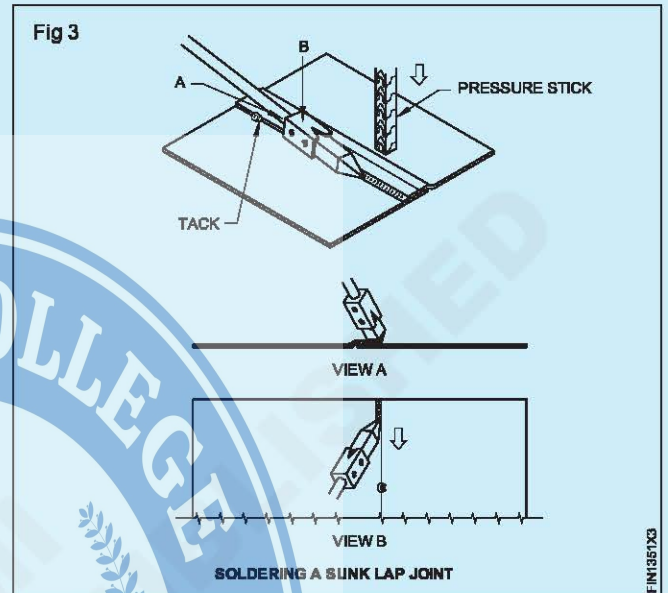

Silver brazing of copper pipes by gas

- Objectives:** This shall help you to
- prepare the edges of copper tubes for bell-mouth butt joints
 - silver braze copper tubes
 - clean and inspect the silver-brazed weld.

Copper tubes are mostly used in a number of fields such as automotive sheet metal trades, airconditioning and refrigeration.

Silver-brazing is the proper method to join the copper tube joints.

Cleaning and preparing the edges (Fig-1)

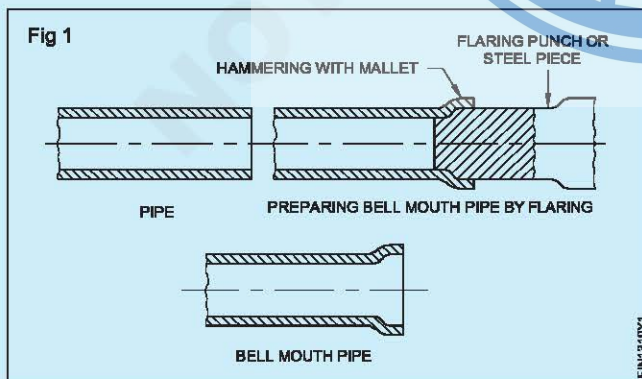

Clean the joining edges by rubbing with an emery paper or steel wool.

Use a steel rod to form bell mouth shape in one end of pipe and hammer around it with a mallet.

Setting the joint pieces (Fig 2)

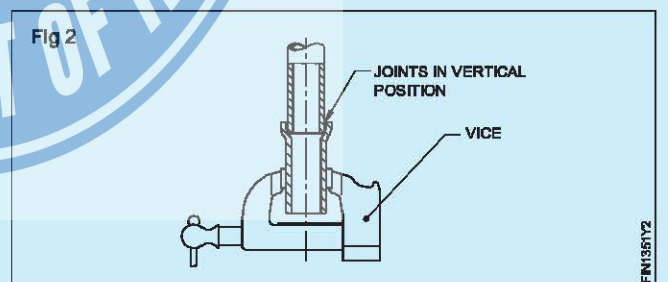

Apply silver-brazing flux on the joining edges.

Set the joint pieces as bell-mouth butt joint maintaining alignment.

Hold the joint pieces in a vertical position in a bench nick Fig.3.

Making silver brazing weld (Fig 3)

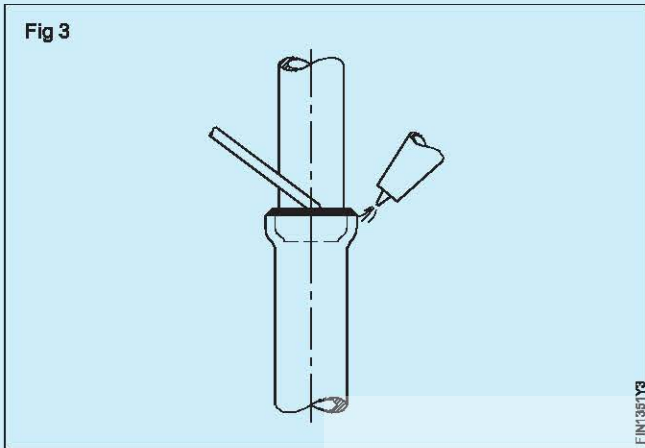

Use a soft carburising flame, produced by nozzle No.1 a silver brazing filler rod $\text{Ø}1.6\text{mm}$ (Type BA-Cu-Ag 16A conforming to IS: 2927 - 1975) and silver-brazing flux.

Heat around the joint to a dull red colour (melting of flux).

Apply, melt and spread the filler rod around the joint by scratching its end with the use of a flux.

Apply the flame gently around the joint and make the filler metal penetrate in the joint.

Never apply a direct flame on the molten filler metal or overheat the joint.

Add more filler rod around the joint, if needed.

Remove the flame and allow the filler metal cool for 10-15 seconds.

Cleaning and inspection (Fig 4)

Clean the joint by rubbing with an emery paper.

Inspect for a smooth and evenly filled, brazed joint without any pin- holes.

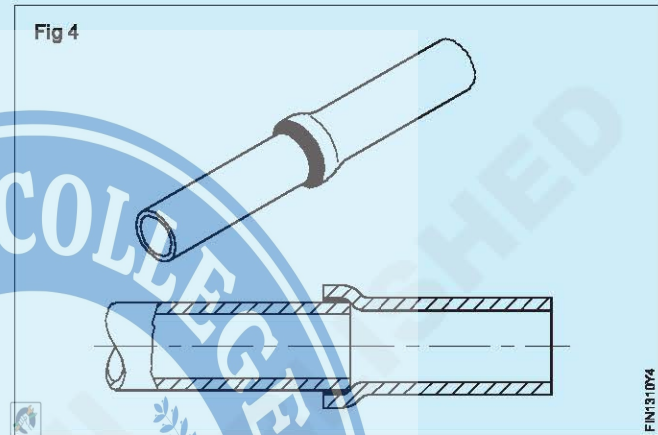

Make riveted lap and butt joint

Objectives: At the end of this exercise you shall be able to

- layout the spacing for rivet holes to make single riveted lap & butt joint
- punch the correct size holes using a solid punch
- rivet the snap head rivets with the help of rivet set, a rivet snap, a dolly using ball pein hammer, to make single riveted lap and butt joint.
- form the rivet heads of snap head and flat head rivets.

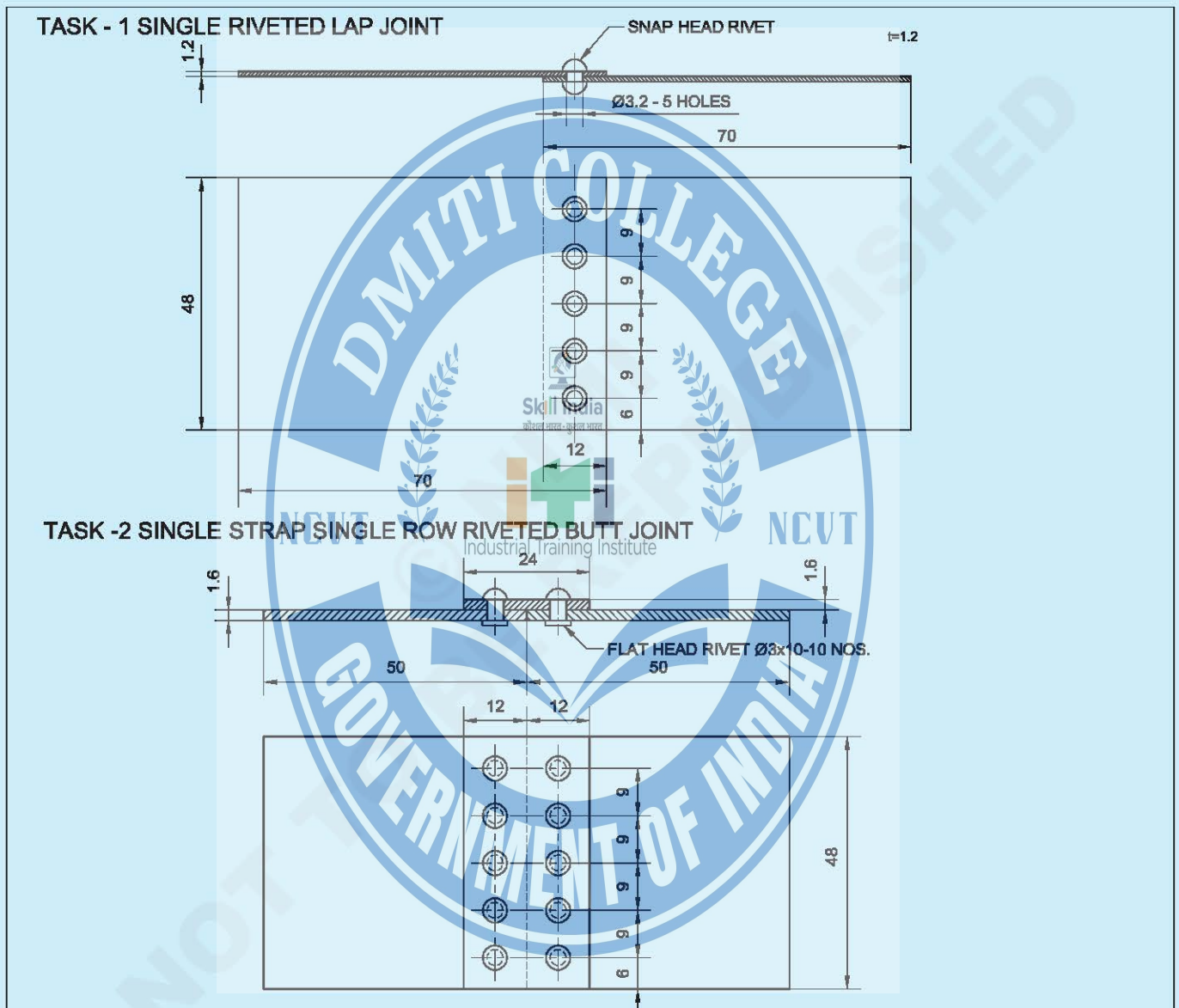

10	IS: 2155 - Ø3 - 6	-	M.S. FLAT HEAD RIVET	-	-	-
1	ISSH 100 x 50 x1.6	-	MILD STEEL SHEET	-	-	-
5	IS:2155 - Ø3 - 5	-	M.S. SNAP HEAD RIVET	-	-	-
1	ISSH 140 x 48 x1.2	-	MILD STEEL SHEET	-	-	1.3.52
NO.OFF	STOCK SIZE	SEMI-PRODUCT	MATERIAL	PROJECT NO.	PART NO.	EX. NO.

SCALE 1:1	SINGLE RIVETED LAP JOINT & SINGLE STRAP SINGLE RIVETED JOINT	DEVIATIONS ±0.5mm	TIME :
		CODE NO. F120N1352E1	

Job Sequence

TASK 1: Single riveted lap joint

- Cut and check the given raw material to the size 140 x 48 mm using a steel rule.
- Flatten the sheet on the dressing plate by a mallet.
- Deburr the edges using a flat smooth file.
- Mark the centre line of length 140 mm and cut the sheet into two pieces of size 70 x 48 using straight snips.
- Layout the spacing for rivet holes to make single riveted lap joint using a scribe and a steel rule on both pieces of the sheet, and mark the centre points of rivet holes using a centre punch and a setting hammer. (Fig 1 & 2 of Skill sequence)
- Punch and make $\phi 3.2$ holes on all centre points on one piece of the sheet and one central hole on another piece of sheet using a solid punch (Fig.1)

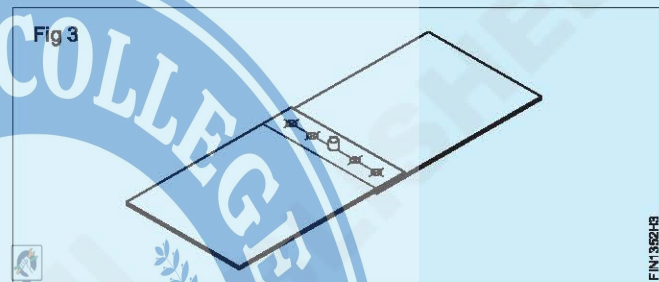
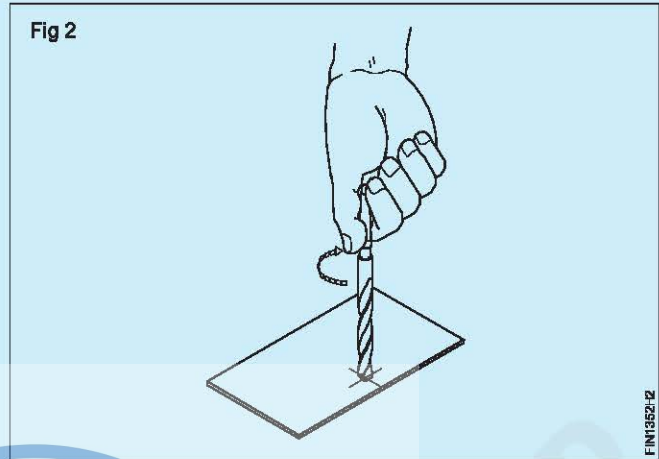
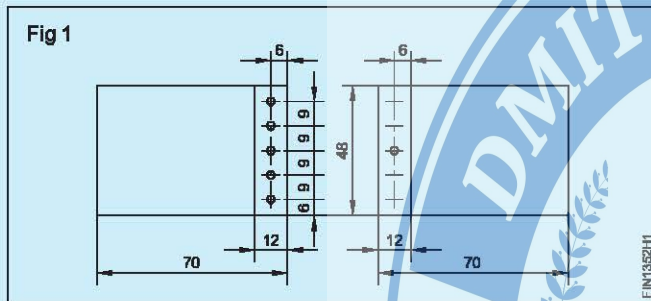

- Deburr the holes with larger sized drill rotating it on drilled holes, by hand. (Fig 2)
- Place the piece of sheet having all holes punched above another, such that the overlapped edges of the sheets coincide with the marked lines.
- Insert 3 mm dia snap head rivet in the centre hole. (Fig.3)
- Form the rivet head, with the help of the rivet snap and dolly using ball pein hammer.

- Punch the remaining four holes on the bottom piece of the sheet, through the holes, already punched on the upper piece of the sheet.
- Deburr the holes with the larger sized drill, rotating it on the punched holes, by hand.
- Insert the rivets in alternate holes and form the rivet heads, one by one to make a single riveted lap joint, with the help of a rivet set, rivet snap, a dolly and a ball pein hammer.

TASK 2: Single strap single row riveted butt joint

- Cut the given material into three pieces, two to sizes of 50 x 48 mm and the third piece of size 24 x 48 mm using a straight snip and check the size using a steel rule. (Fig.1)
- Flatten the sheet on the dressing plate by a mallet.
- Deburr the edges using a flat smooth file.
- Layout the spacing for rivet holes to make single strap single riveted butt joint using a scribe, a divider and a steel rule on the pieces of sheets. (Fig. 1)
- Mark the centre point for the rivet holes using a centre punch and a ball pein hammer.
- Drill $\phi 3.2$ mm holes at all the points on the strap and the centre holes on the two workpieces to be joined.
- Deburr the holes with larger sized drill by rotating it on the drilled holes by hand.

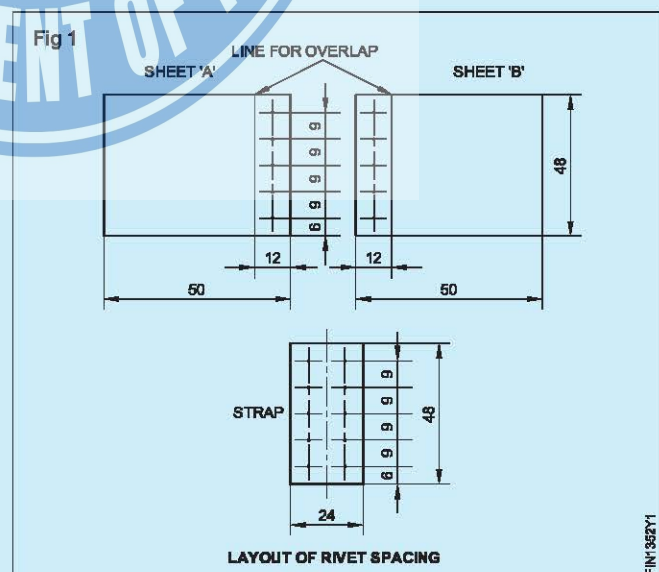

Riveting snap head rivet

Objective: This shall help you to

- make proper use of the dolly, rivet set and rivet snap to perform correct riveting
- form the rivet head in round shape, by applying the hammer blows properly by the ball pein hammer
- rivet snap head rivet to make the riveted joint tight without damaging the base metal.

Ensure that all the rivet holes are drilled on one sheet and only one hole for the centre rivet is drilled on another sheet.

Ensure that the drilled holes are deburred and the sheets are flat.

Hold vice dolly rigidly in the bench vice.

Place the sheet having all holes drilled over the other, align the drilled hole and coincide the marked lines for lap with the edges.

Insert the rivet in the centre hole and place the rivet head on the vice dolly, to avoid deformation, while hammering. (Fig 1 & 2)

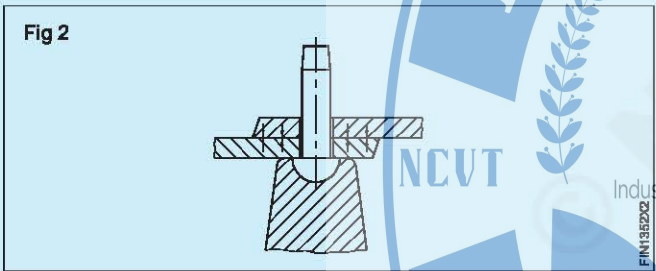
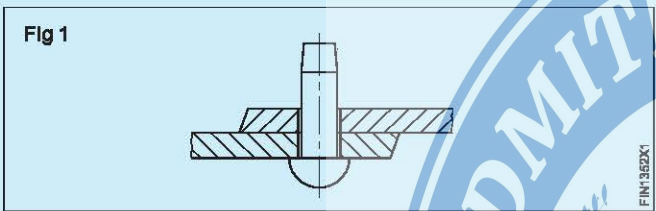

Place the deep hole of the rivet set over the shank of the rivet. (Fig 3)

Strike the rivet set with a ball pein hammer to bring the sheets closer, to set the joint firmly for riveting. (Fig 3)

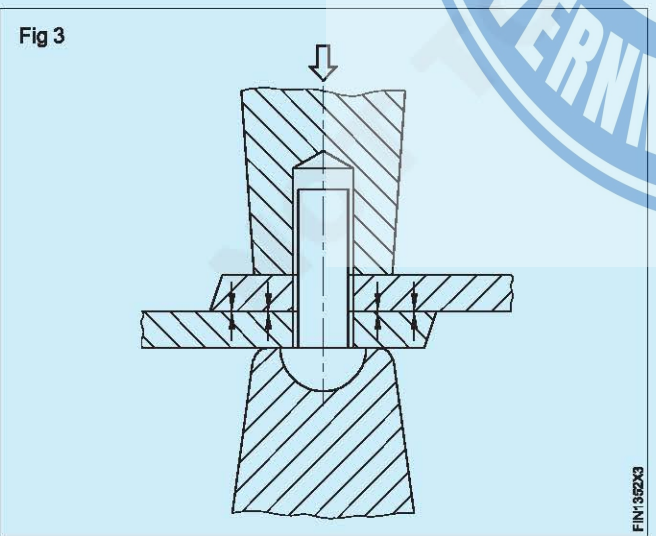

Remove the rivet set over the shank of the rivet.

Form the rivet head roughly by hammering it down initially and then rounding the head using a ball pein hammer. (Fig 4 & 5)

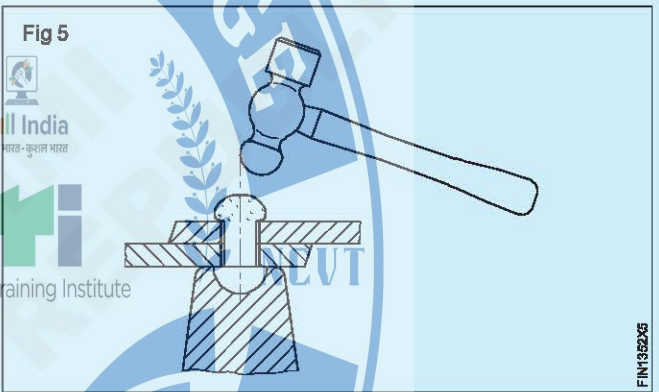
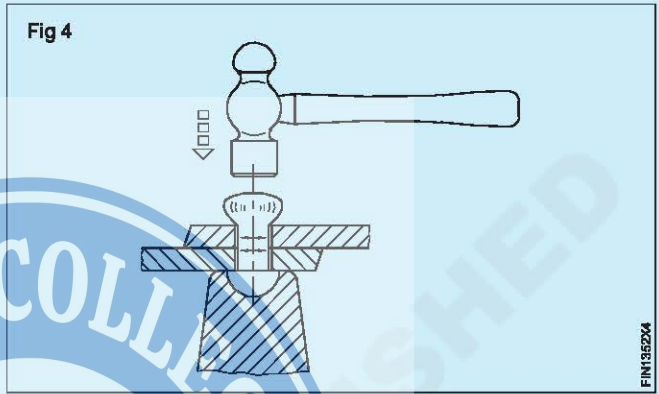

Place the rivet snap over the rounded head of the rivet and strike with a hammer over it to form and finish the rivet head using a ball pein hammer. (Fig 6)

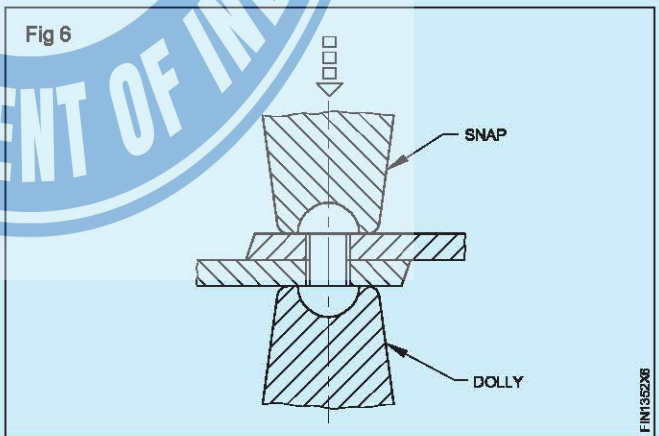

Layout the spacing for rivet holes to make single strap single riveted butt joint

Objectives: This shall help you to

- calculate the breadth of a cover plate. Distance between the centre of first rivet and the edges and distance of pitch as per BIS Standard
- layout the spacing for rivet holes to make single strap single row riveted butt joint.

Ensure that the edges of the workpieces to be joined are free from burr and straight. First layout the spacing of rivet holes on the workpieces to be joined.

Calculate the dia of the rivet.

Diameter of the rivet (D) = $2.5 T$ or $3T$, where T = Total thickness of sheets to be joined.

Calculate the distance of lap.

Distance of lap = $8 \times D$

Mark the line of distances of lap on both workpieces using a scribe and a steel rule. (Fig 1)

Calculate the distance of the rivet line from the edge of the sheet.

Distance of the rivet line from the edge = $2 \times$ the diameter of the rivet (D).

Mark the rivet lines parallel to the edge on workpieces. (Fig.1)

Calculate the distance of the first rivet from the side edge of a butt.

Distance of first rivet from the side edge = $2 \times$ dia of Rivet (D)

Mark the distance of first rivets from side edges on the rivet line, on the workpieces.

Calculate the distance between the two rivets i.e the pitch.

Pitch = $3 \times$ dia of the rivet

Mark the pitch of the rivet on the rivet lines on workpieces using a divider. (Fig 1)

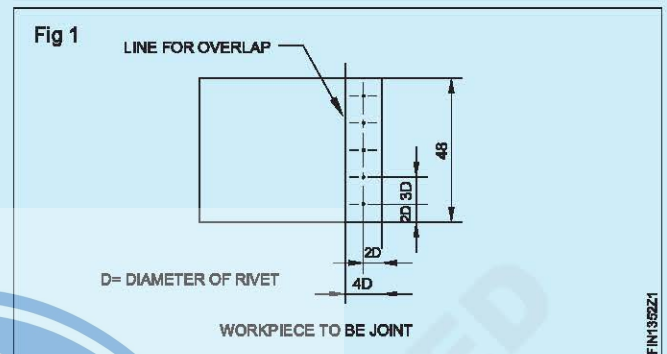

Punch on the centre point of the rivets using a centre punch and a ball peen hammer.

Layout the spacing of rivet holes on strap: Similarly, as mentioned above, mark two rows of rivet holes at a distance of $4D$ on strap Fig.2

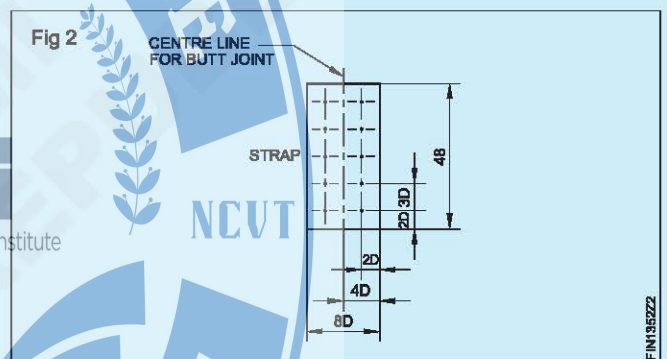

Make funnel as per development and solder joints

Objectives: At the end of this exercise you shall be able to

- make straight wired edge
- make curved wired edge
- fold sheet metal at angle using.

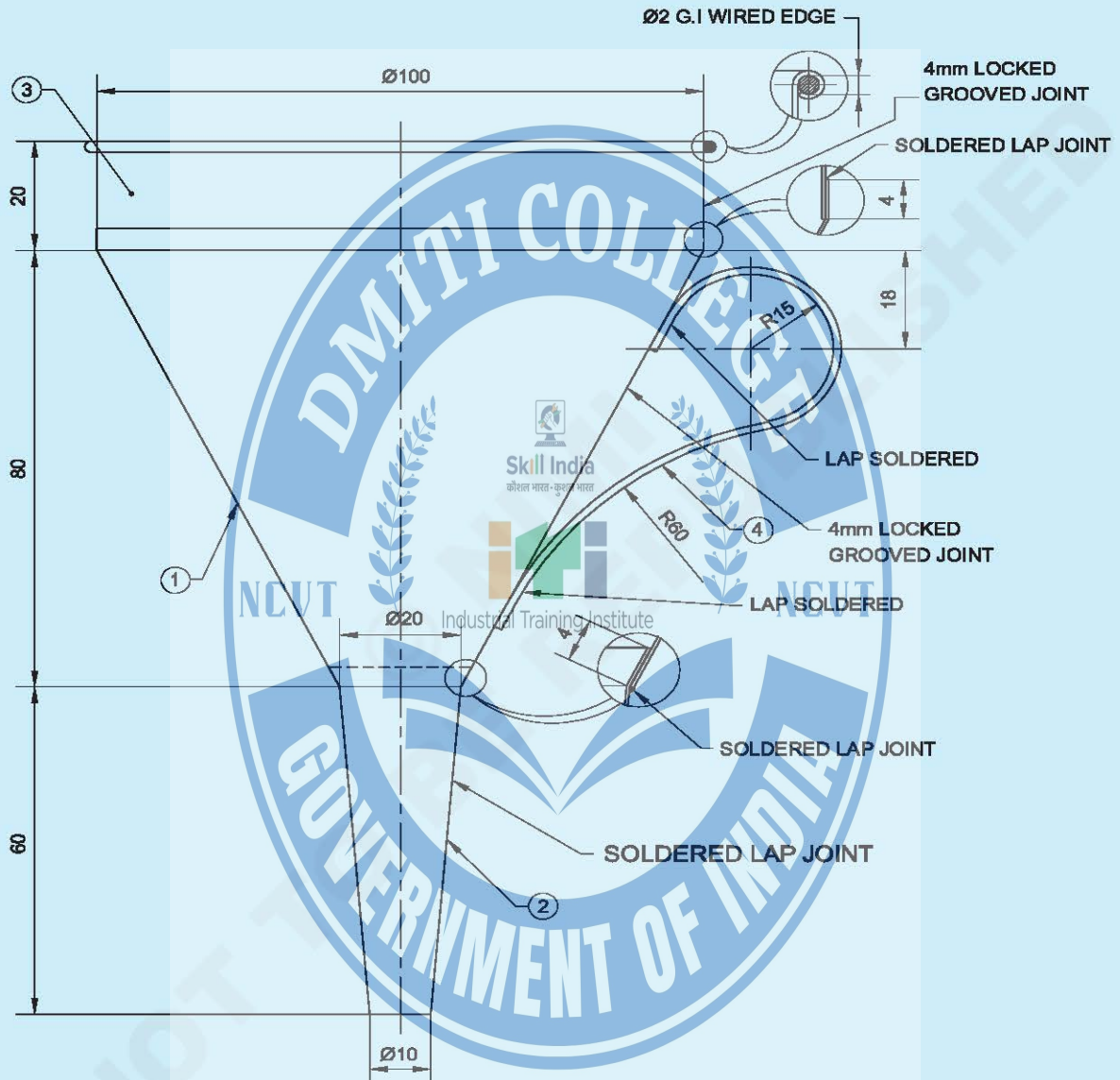

-	-	-	SOFT SOLDER 60:40	-	-	-
1	Ø2 - 360	-	G.I WIRE	-	-	-
1	ISSH 160 x 25 x 0.5	-	G.I SHEET	-	4	-
1	ISSH 335 x 30 x 0.5	-	-	-	3	-
1	ISSH 125 x 80 x 0.5	-	TINNED SHEET	-	2	-
1	ISSH 250 x 140 x 0.5	-	TINNED SHEET	-	1	1.353
NO.OFF	STOCK SIZE	SEMI-PRODUCT	MATERIAL	PROJECT NO.	PART NO.	EX. NO.
SCALE: NTS		MAKE A FUNNEL (BY SOLDERING)			DEVIATIONS ±1	TIME :
					PROJECT: FUNNEL PART: 1, 2, 3 & 4	

TASK-1

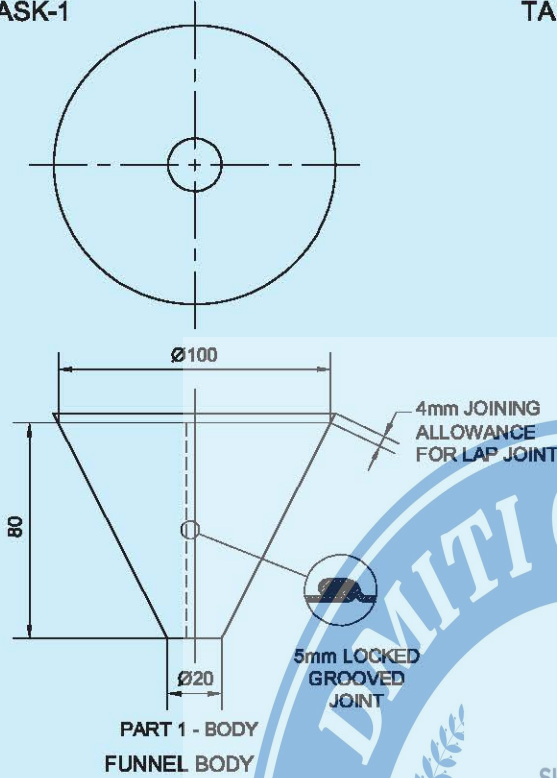

TASK-3

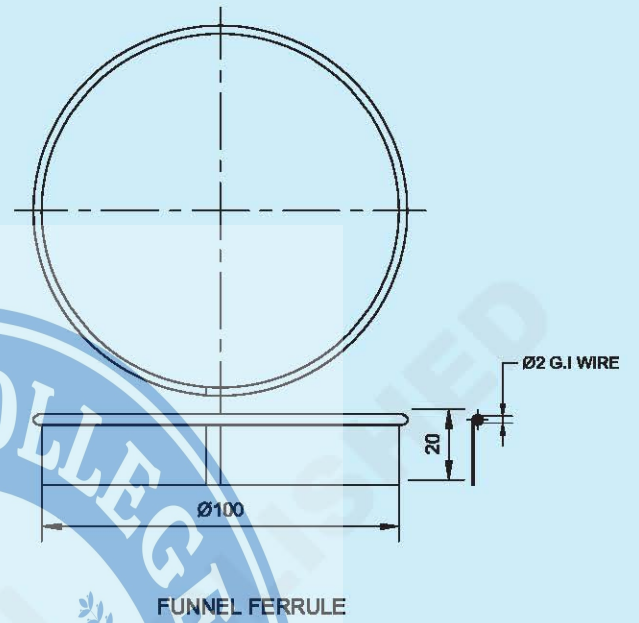

TASK-2

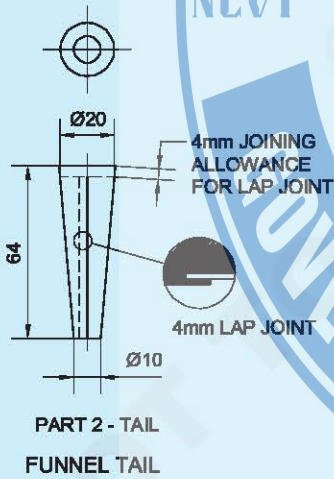

TASK-4

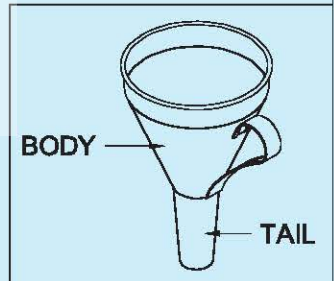
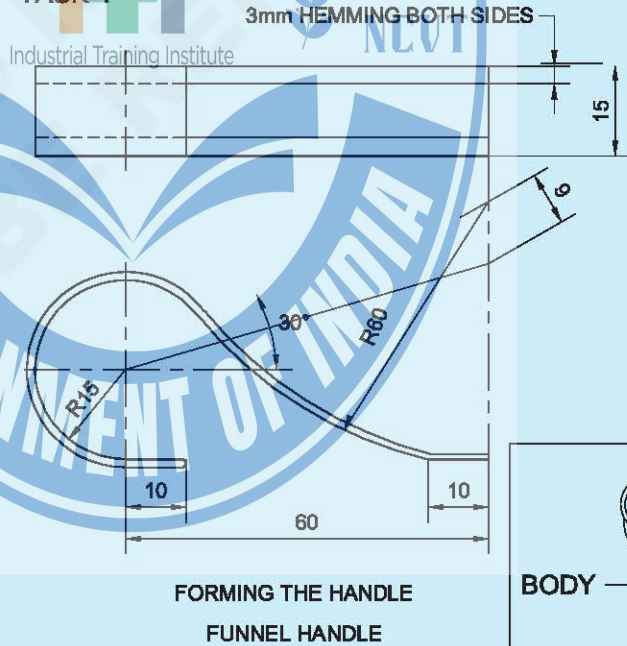

-	-	-	-	-	-	1.3.53
NO.OFF	STOCK SIZE	SEMI-PRODUCT	MATERIAL	PROJECT NO.	PART NO.	EX. NO.
SCALE 1:2	MAKE A FUNNEL (SEAMING THE BODY AND THE TAIL)				DEVIATIONS ±1	TIME
	PROJECT: FUNNEL		PART: 1. BODY 2. TAIL		CODE NO. F120N1353E2	

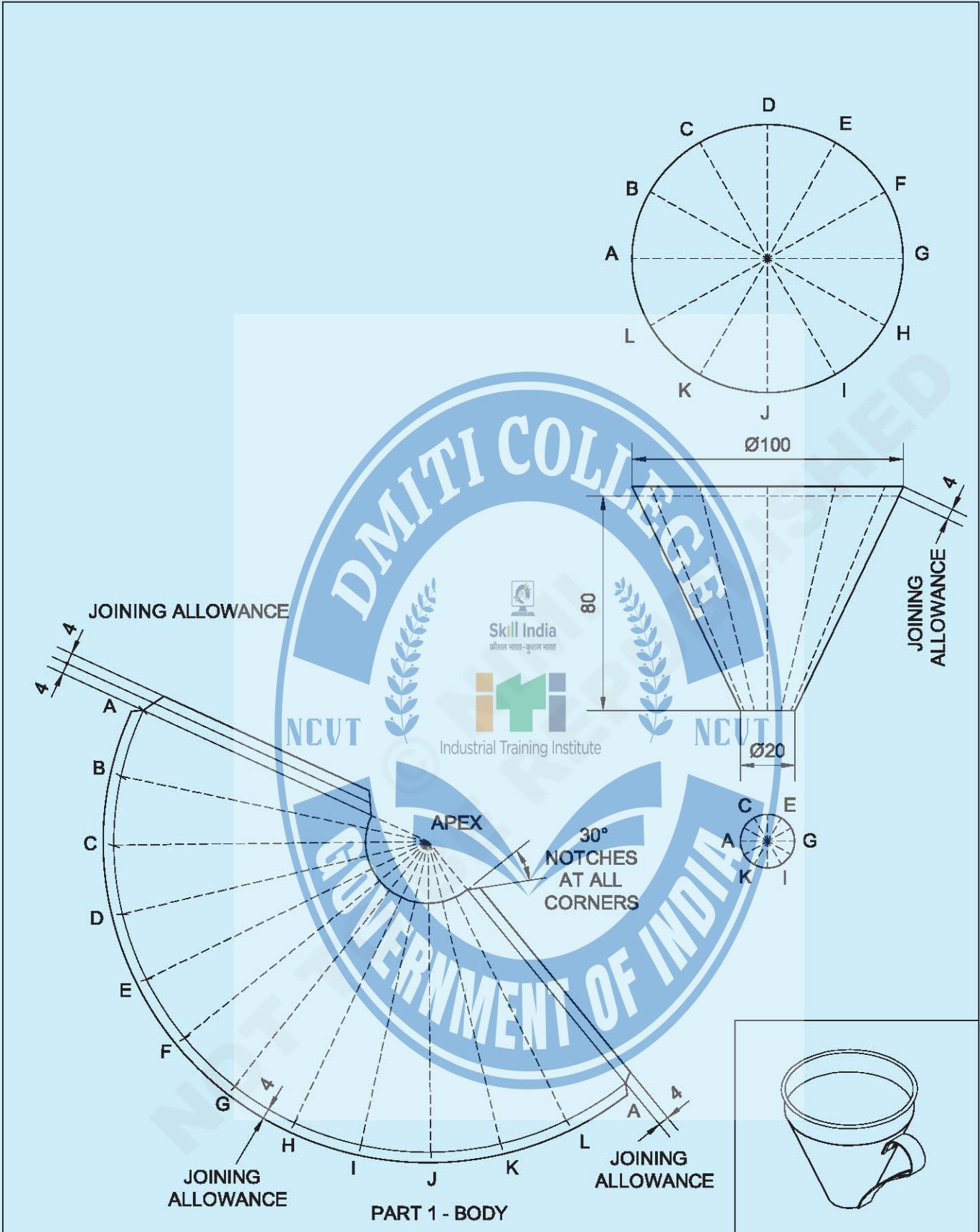

						1.3.53
NO.OFF	STOCK SIZE	SEMI-PRODUCT	MATERIAL	PROJECT NO.	PART NO.	EX. NO.
<p style="text-align: center;">MAKING A FUNNEL (BODY PATTERN CUTTING)</p> <p>PROJECT: FUNNEL PART: BODY</p>					DEVIATIONS ±1	TIME
					CODE NO. FI20N1348E5	

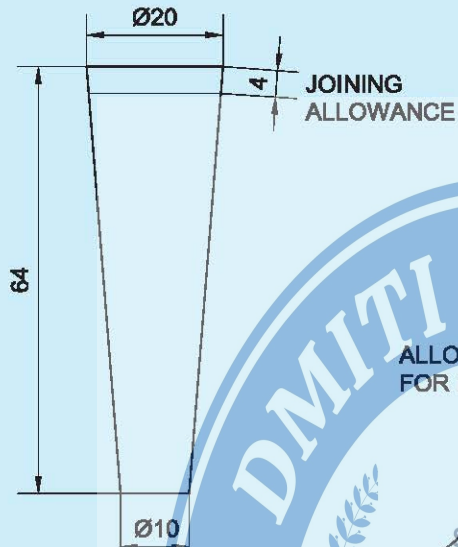
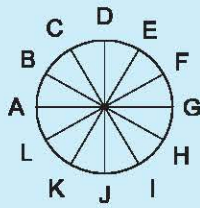

APEX

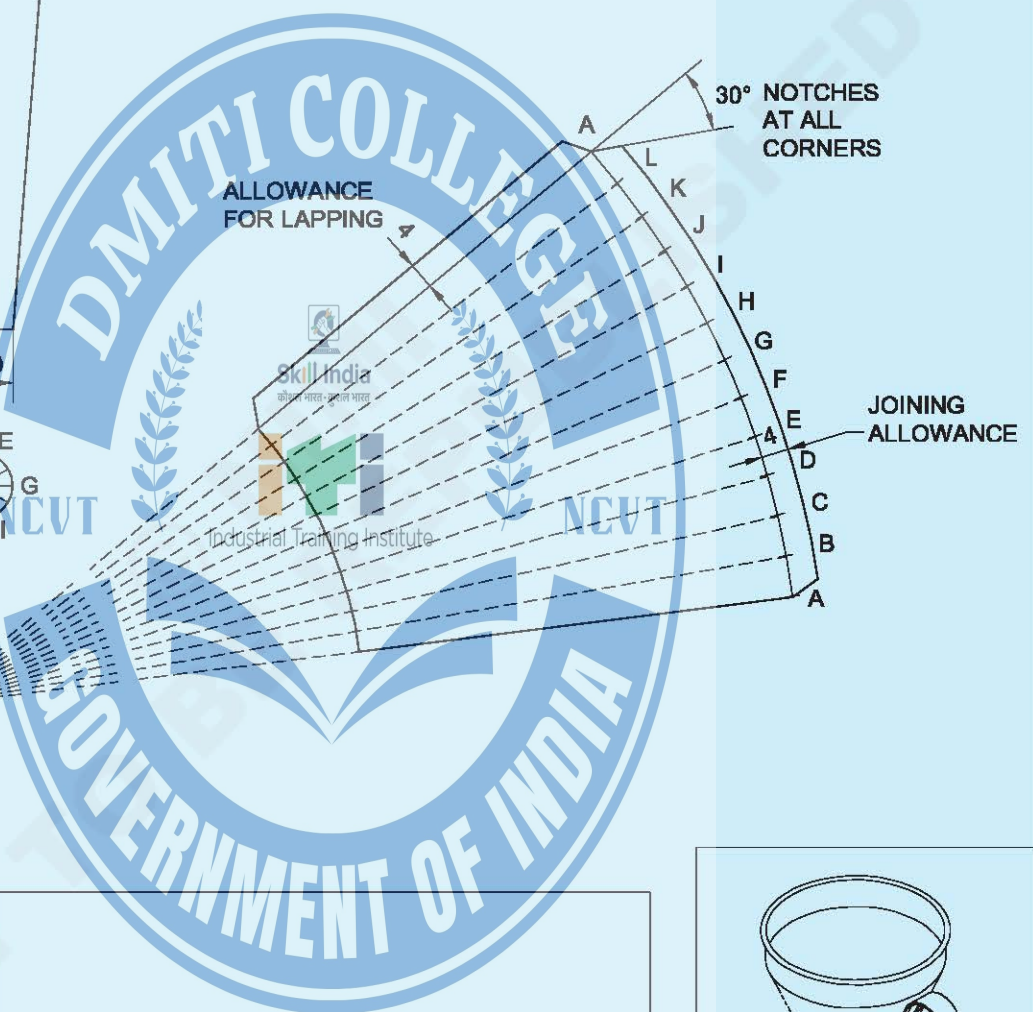

TASK-5

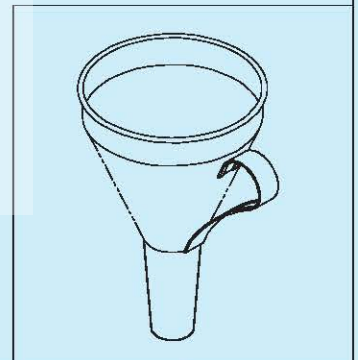
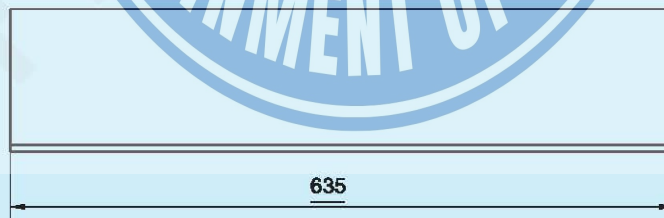
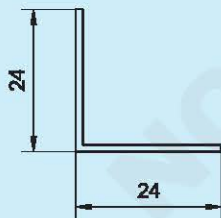

NO.OFF	STOCK SIZE	SEMI-PRODUCT	MATERIAL	PROJECT NO.	PART NO.	EX. NO.
SCALE 1:1		<p align="center">MAKING A FUNNEL (TAIL PATTERN CUTTING)</p>			DEVIATIONS ±1	TIME :
					<p>PROJECT: FUNNEL PART: TAIL</p>	

Job Sequence

TASK 1: Make a funnel PART 1 (Funnel Body)

- Develop and layout the pattern for the body of a funnel (frustum of a cone) with joining allowances on a plain drawing paper using a geometry box (instrument box)
- Cut the layout pattern using scissors and paste it on the given raw material (sheet metal) using fevicol/gum.
- Cut the sheet metal on the outlines of the layout pattern of the paper so pasted, using a straight and bend snips.

TASK 2: PART 2 (Funnel Tail)

- Develop and layout the pattern for the tail of funnel (frustrum of a cone) with all allowances for joining on a plain drawing paper using a geometry box. (Instrument box)
- Cut the layout pattern using scissors and paste it on the given sheet metal using fevicol/gum.
- Cut the sheet metal on the outlines of the layout pattern of the paper so pasted, using a straight and bendsnips.

TASK 3: PART 3 (Funnel Ferrule)

- Cut the sheet metal to the size 335x30, flatten the sheet and deburr the cut edges.
- Refer the skill sequence for development 1.3.43 of cylinder.
- Develop the pattern layout on sheet considering the wiring allowance for 2mm dia. wire, the seaming allowance for 4mm locked groove joint and cut the pattern with clips using a straight snip.
- Form the circular shape with locked grooved joint using a round mandrel stake, a hand groover, a ball pein hammer and a mallet.
- Make a 2mm dia wired edge along the circular edge of the ring using a half moon stake and a setting hammer.
- Dress and check the ring for shape and dimensions.

TASK 4: PART 4 (Funnel handle)

- Make a handle (Part 4) as per drawing using funnel stake and mallet.
- Inspect the finished article for sharp edges, burr or any irregularity and rectify if necessary.
- Wash the article with cold water.

Assembly of funnel

- Bend the joining allowance at larger end of body (Part 1) using anvil stake and mallet. (Fig.1)
- Insert the ferrule (Part 3) in body (Part 1) and solder.
- Solder the lap joint of the tail. (Part 2)
- Flare 4mm edge of the larger dia end of the tail (Part 2) to position it securely into the body.
- Insert the tail in the body and solder.
- Position the handle (Part 4) and solder as per job drawing.

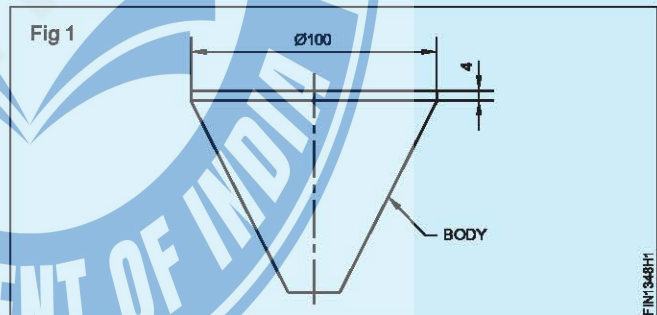

TASK 5: Folding the sheet metal to 90°

- Cut the job material 135x48 mm using a straight snip.
- Mark the job material with a scribe using a steel square. (Fig 1)
- Mark the folding line to bend at 90°.
- Position the marking line to the edge of the bevelled hatchet stake.
- Strike the edge using mallet by holding the other end of the job.
- Ensure the folding takes place on the bend line as required.
- Continue to strike the job to fold at 90° angle.
- Check the perpendicularity of the job by a try square.
- Rectify the perpendicularity, using a wooden mallet, supporting the job on a hatchet stake, if required.

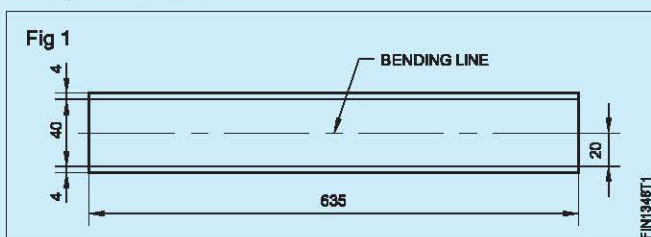

Skill Sequence

Development for a circular cone

Objective: This shall help you to

- develop a circular cone by the radial line development

develop a circular cone by the radial line development (Fig 1)

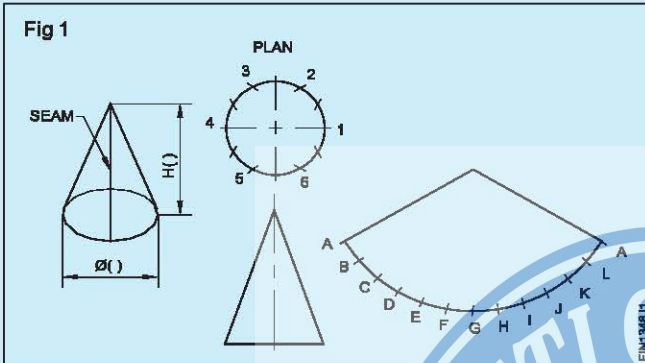

Circular cone: Draw the front elevation and the plan. (Fig.2)

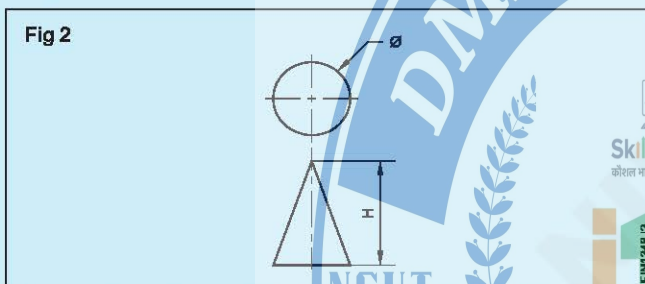

While drawing the plan, the neutral plane (outer diameter plate thickness) of the base circle is taken as the diameter.

The neutral plane size is negligible, if the plate thickness is less than 0.5 mm.

Divide accurately the circumference of the plan into 12 equal parts. (Fig 3)

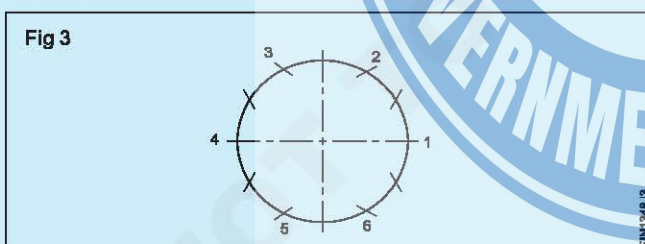

With the radius of the circle, first divide the circumference into 6 equal parts.

Then divide each part into two.

Draw a perpendicular line on the material. (Fig 4)

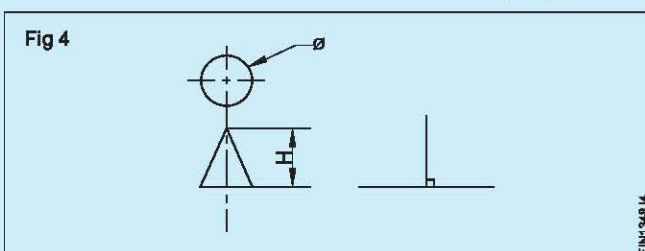

Draw a perpendicular line to the centre of the material blank space.

Transfer the length of the edge line (slant height) to the compass. (Fig 5)

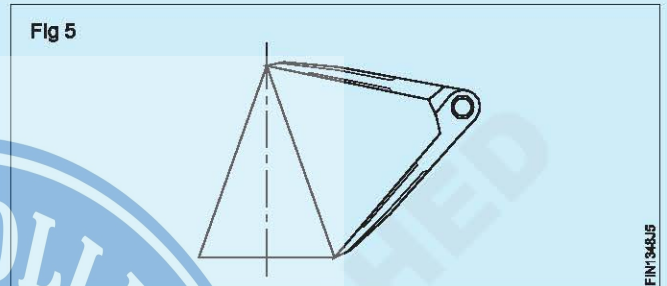

Transfer it accurately.

Draw an arc with the centre at a point on the perpendicular line (Fig 6) and the slant height as the radius.

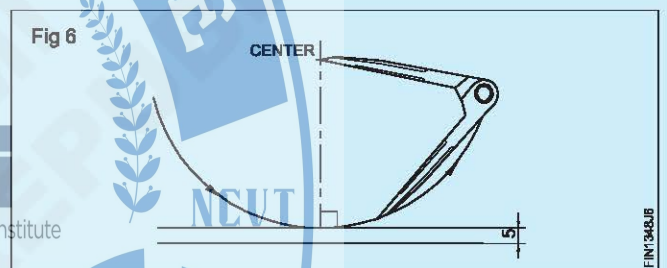

Check the opening of the compass with each equally divided points, to minimise errors.

Open the compass points to one of the 12 equally divided parts of the circumferential length.

Open the compass by checking each equally divided point to minimise errors.

Scribe 12 opening points of the compass on the arc.

Scribe six points on both the right and left sides of the perpendicular respectively. (Fig 7)

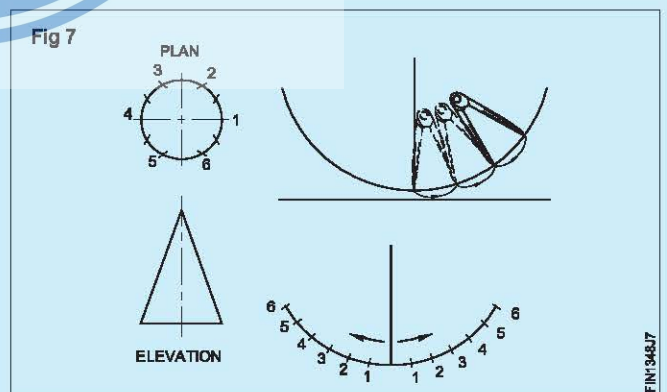

Use the compass points alternately while scribing points, without removing the compass from the arc at a time.

Connect the right and left ends of the arc to the centre. (Fig.8)

Fig 8 shows the development for the given cone.

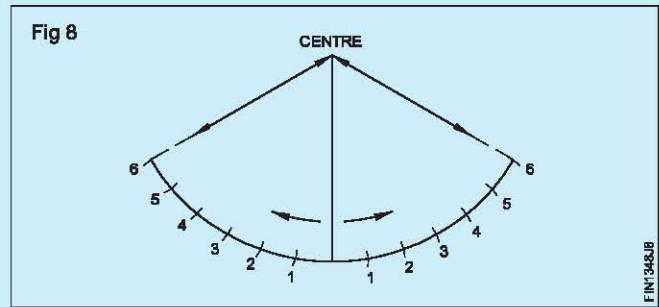

Develop and layout the pattern for the frustum of a cone by radial line method

Objective: This shall help you to

- develop and layout the pattern for the frustum of a cone by radial line method.

Get a plain drawing paper large enough to make the flat pattern layout.

Draw the elevation of the frustum of a cone in full size 'AGMN' in Fig 1.

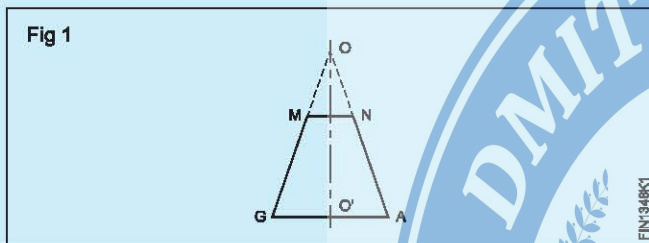

Continue the lines showing taper sides of the body till they intersect at a point 'O'. 'O' is called as an 'Apex'. (Fig 1)

Taking O' as the centre and O'A as radius, draw an arc AG and divide it into six equal parts A-B-C-D-E-F-G. (Fig 2)

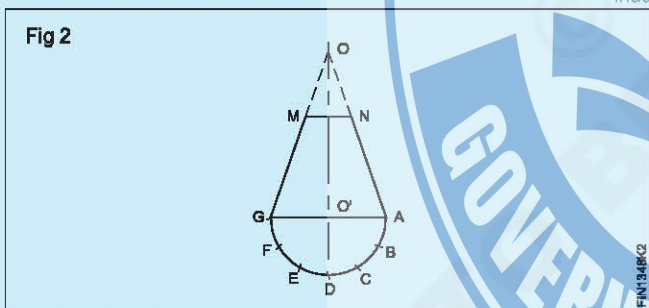

With centre 'O' draw arcs 'AX' and 'NY'. X&Y are the points on the centre line of the frustum of a cone. (Fig 3)

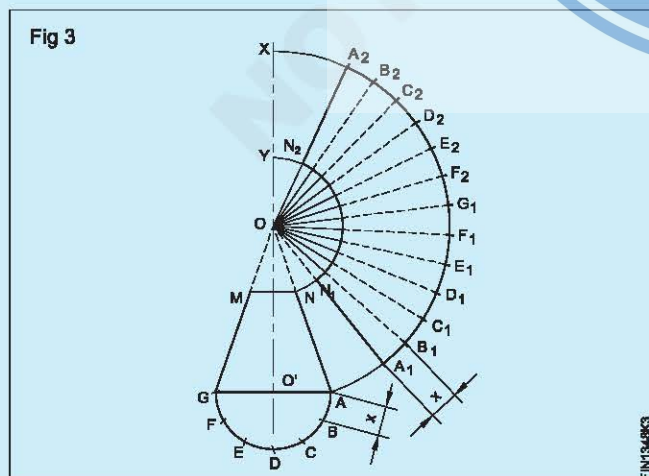

Take distance 'X' and mark off twelve lines along the arc AX to obtain A¹-B¹-C¹-D¹.... to D²-C²-B²....A². (Fig 3)

Join the points A¹, B¹, C¹, C², B², A² to the point 'O'

The development required is A¹A²N¹N².

This is the development of a frustum of a cone without a joining allowance.

Now add joining allowances 'a' & 'b' by drawing lines parallel to A¹N¹ & A²N². (Fig 4)

Add hemming or wiring or joining allowance 'c' & 'd' by drawing arc inside the arc N¹N² and outside the arc A¹A². (Fig 4)

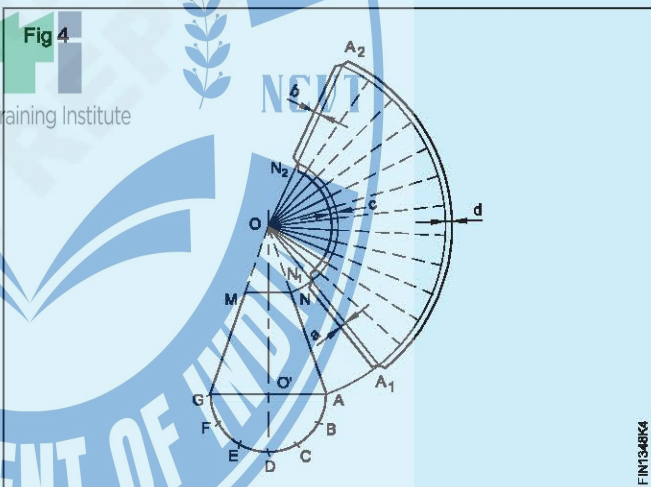

PART 1 (Body)

- Flatten the sheet metal using a wooden mallet and a Tinmans anvil stake. Fig 1)

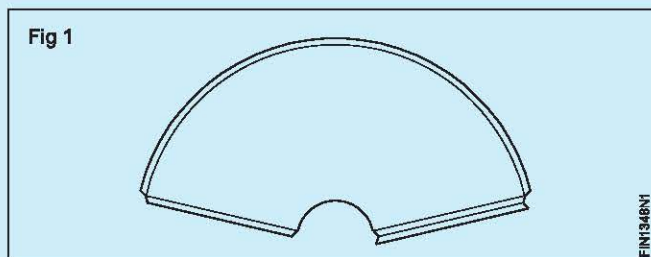

- Check the allowances for the locked grooved joint using a steel rule.

- Form hooks on both the ends in opposite directions by using a hatchet stake, a wooden mallet and a 1/2 lb ball pein hammer.

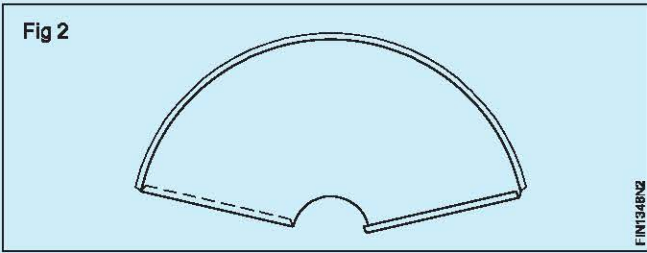

- Form the sheet metal to the frustum of cone by using a funnel stake. (Fig 3)

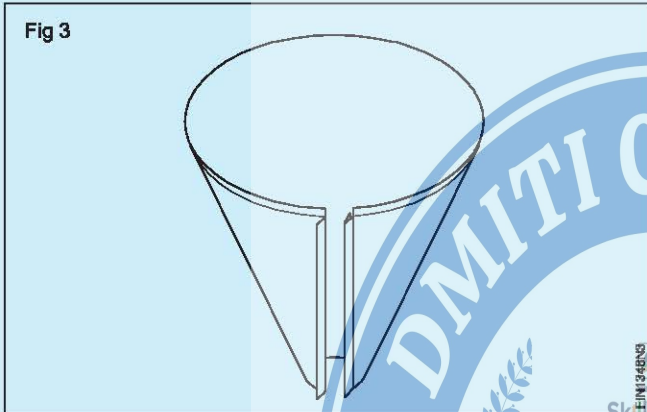

- Make a locked grooved joint by using a funnel stake, a hand groover and a 1 1/2 lbs ball pein hammer. (Fig 4)
- Finish the job using a wooden mallet.
- Check the dimensions of the job by using a steel rule.

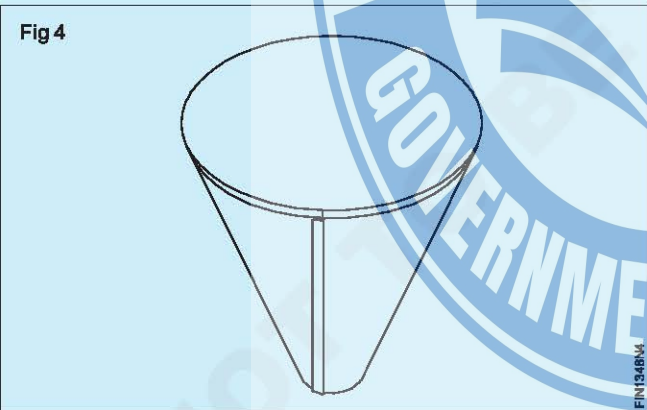

Part 2 (Tail)

- Flatten the sheet metal using a wooden mallet and a Tinmans anvil stake. (Fig 5).

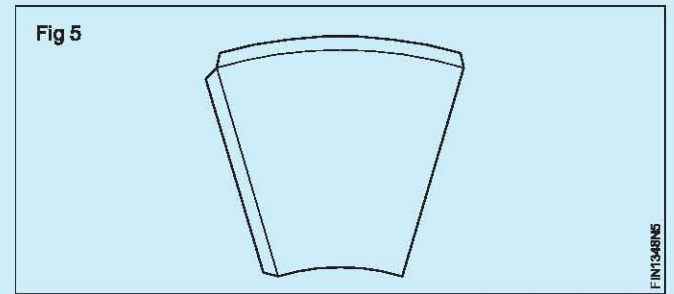

- Check the allowance for the lap joint by using a steel rule.
- Form the sheet metal into frustum of cone using a long tapered beak frustum of cone with a long tapered beak horned iron stake. (Fig 6)

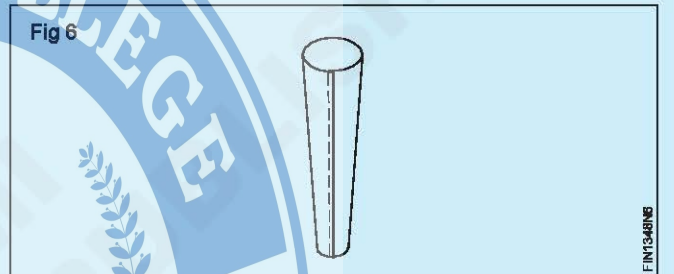

Forming a frustum of a cone with locked grooved joint

Objectives: This shall help you to

- form a frustum of cone using a funnel stake and a wooden mallet
- make locked grooved joint on tapered curved surface using a funnel stake, hand groover and a ball pein hammer.

Check the pattern and ensure that all the required allowances are provided by using a steel rule as per the job drawing. (Fig 1)

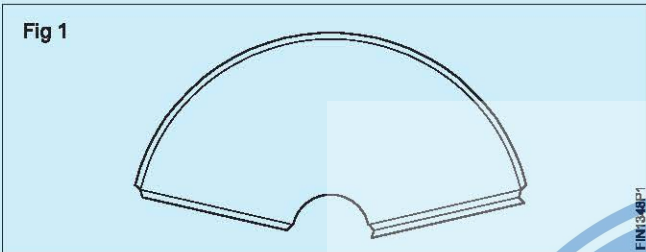

Remove burrs by using a flat file. Mount the hatchet stake on the bench plate.

Place the sheet horizontally on the hatchet stake edge at the line marked previously for folding.

With a wooden mallet strike the edge of the job on both ends. (Fig 2) Observe break or fold mark formed.

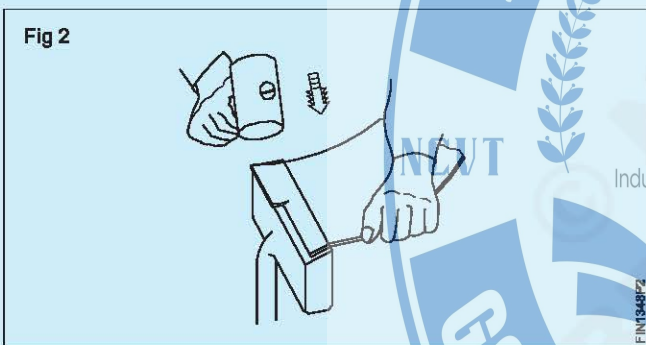

Lower the end of the work slightly using the same angle of striking, increasing the angle of turning.

Repeat the above operation till the edge is turned to the required angle. (Fig 3)

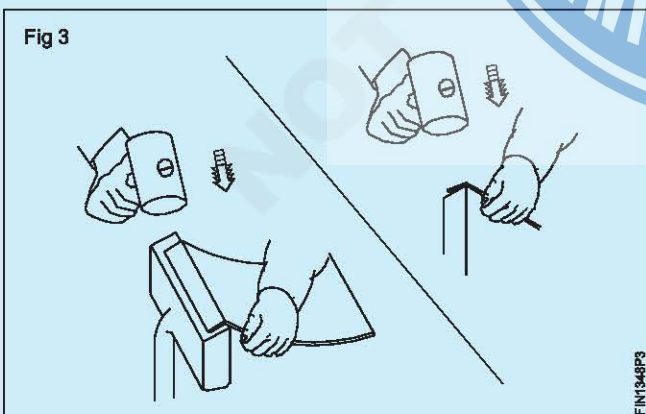

For turning more than 90°, support the work flat against the face of the stake.

Grip the stake with fingers at 'A' and hold the work in position with the thumb. (Fig 4)

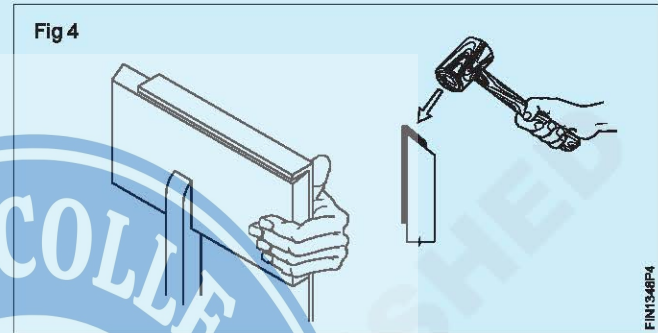

Mallet the edge over a piece of waste tin plate. (Fig 5)

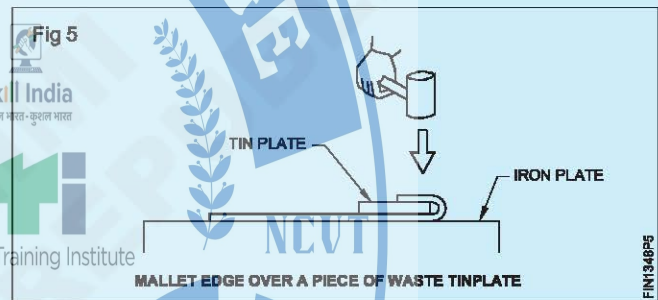

Repeat the same operation on the other edge of the sheet and form hooks. (Fig 6)

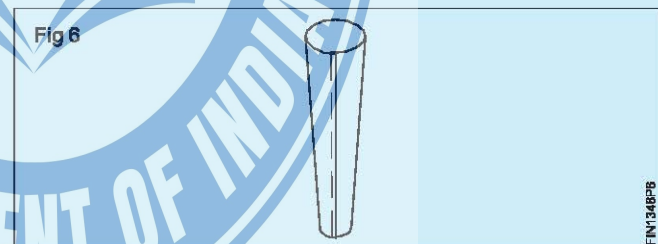

Mount the funnel stake on a bench plate. (Fig 7a) Use "long tapered beak horned iron stake" for the cones having small radius, plate. (Fig 7b & 7c)

Fig 7

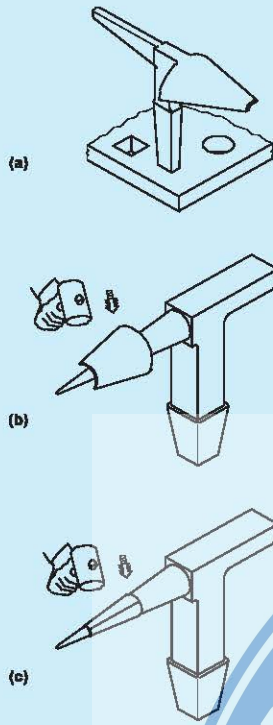

Ensure that the folded edges of the workpiece are parallel, if not the edges will not match as shown in (Fig 11)

Fig 11

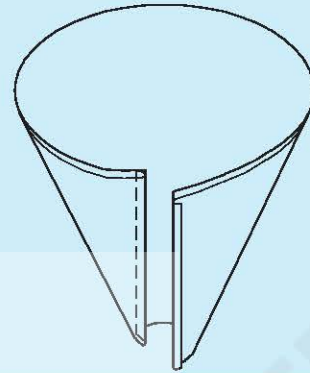

Place one end of the work piece on the funnel stake parallel to the axial line of the stake and bend as shown in Fig 8.

Hook the folded edges as shown in Fig 12.

Fig 12

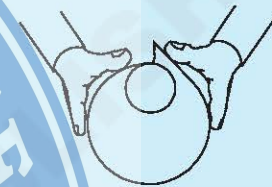
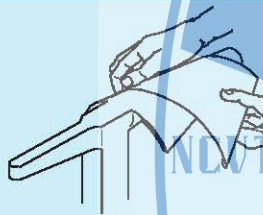

Fig 8



Slowly lock the edges by light blows using a mallet as shown in (Fig 13) Start blows from one end of the joint to the other end to tighten the joint. (Now grooved seam is formed)

Repeat the same operation on the other end of the workpiece. Bend the workpiece evenly as shown in (Fig 9).

Fig 13

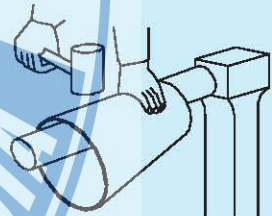

Fig 9



Check the turned up edge of the circular disc and curve it gradually and make both ends to meet together. (Fig 10)

Select the correct size of the groover.

Place the groover over the grooved joint as shown in (Fig 14)

Fig 10

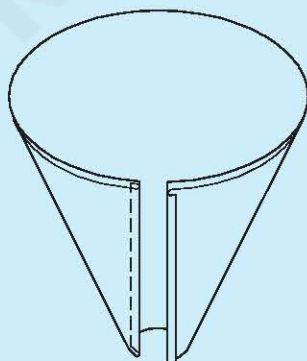
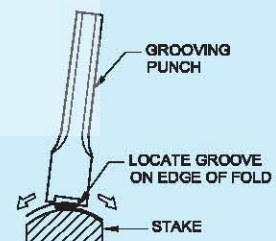
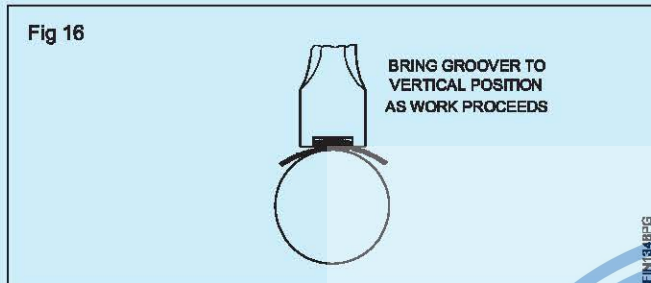
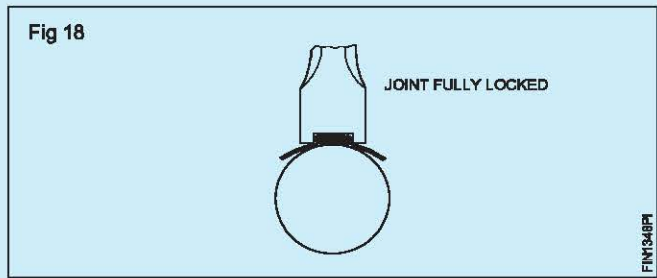
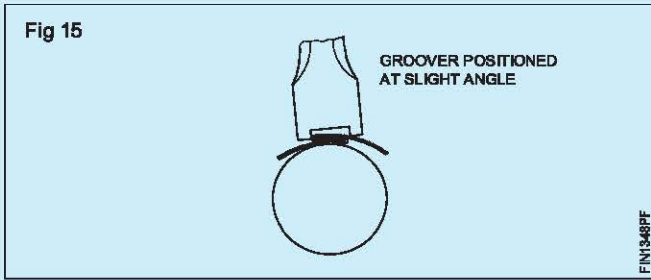

Fig 14



Position the groover at a very slight angle. The edge of joint acts as a guide to the groover. (Fig 15)

Bring the groover to vertical position. (Fig 16)



Strike the top of the groover firmly with ball peen hammer and lock same on the other end. (Fig 17)

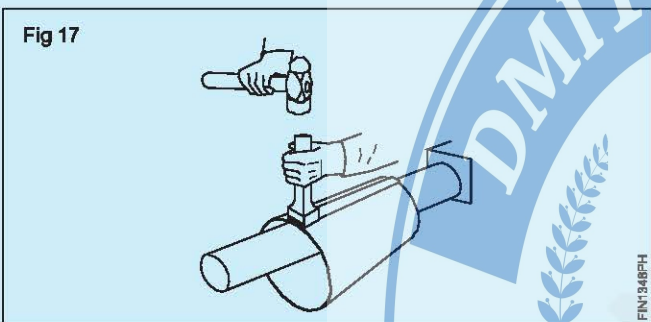

Check the ends again to ensure that they are in line. Continue to lock the seam along the line with the hand groover.

Now the joint is fully locked. (Fig 18)

Finally smoothen with a mallet all over the body and check the dimensions as per the job drawing by using a steel rule.

In order to get proper setting of seam of the required size, it is necessary to use the correct size of a groover. If not, the seam is set too wide or too narrow. Figs 19, 20 & 21.

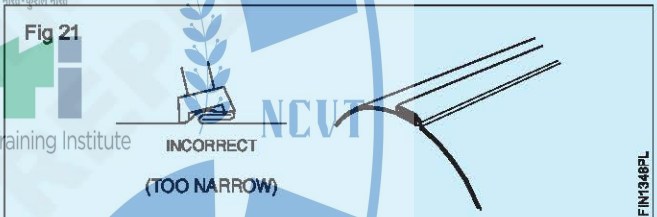
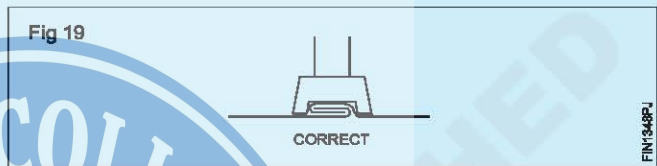

Drill for riveting

Objectives: At the end of this exercise you shall be able to

- mark the drill holes as per drawing
- clamp and drill holes in sheetmetal for riveting using electric portable drilling machine.

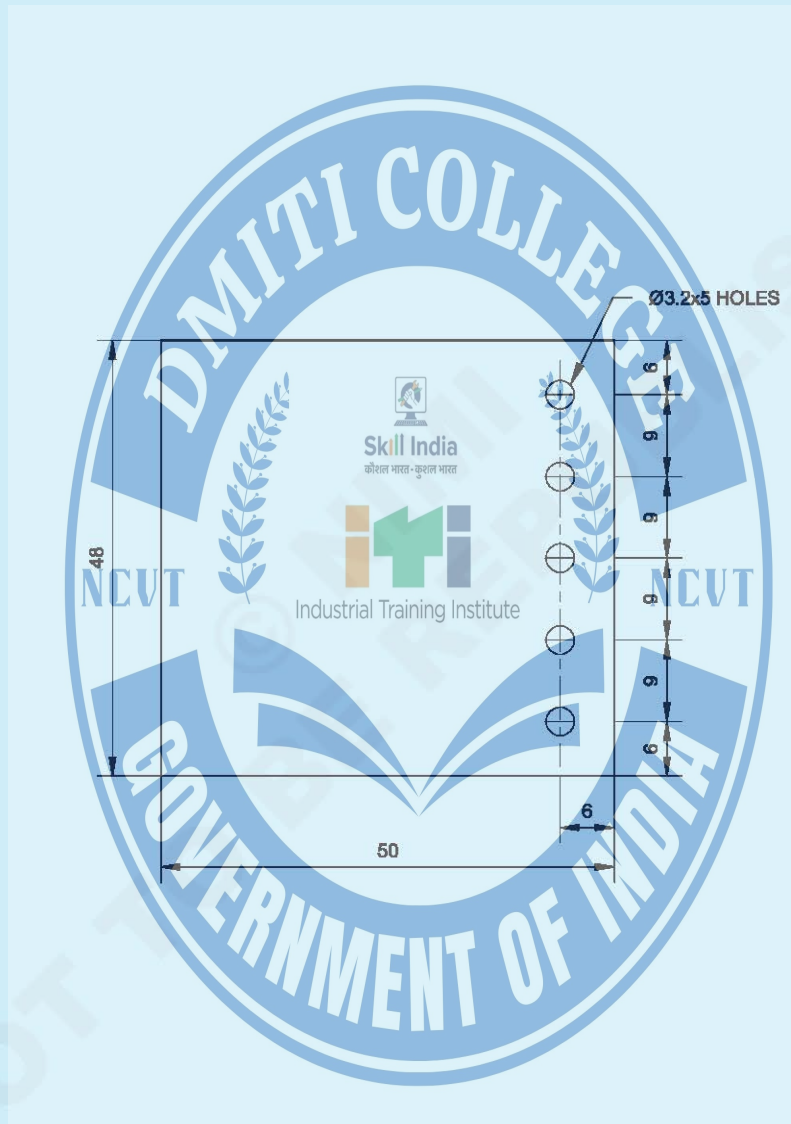

2	ISSH 50 x 48 x1.2	-	G.I SHEET	-	-	1.3.54
NO.OFF	STOCK SIZE	SEMI-PRODUCT	MATERIAL	PROJECT NO.	PART NO.	EX. NO.
SCALE 1:1	DRILL FOR RIVETING				DEVIATIONS ±0.5mm	TIME :
					CODE NO. F120N1354E1	

Job Sequence

- Check the size of sheet 48x50mm using a steel rule.
- Flatten the sheet on dressing plate using mallet.
- Layout the spacing for drill holes and mark the centre points of drill holes using a centre punch and a ball pein hammer.
- Hold the sheet firmly using 'C' clamp.
- Drill \varnothing 3.2mm through holes as per drawing.
- De-burr the holes with larger sized drill by rotating it on the drilled holes by hand.

Skill Sequence

Drilling on sheetmetal by power operated portable drilling machine

Objective: This shall help you to

- **drill correct size hole on sheetmetal by operating power operated portable drilling machine properly.**

Punch the marked centre points of the holes to be drilled lightly using a centre punch and a ball pein hammer.

Insert a straight shank, drill bit in the drill chuck of the portable drilling machine and tighten with the chuck key. (Fig 1)

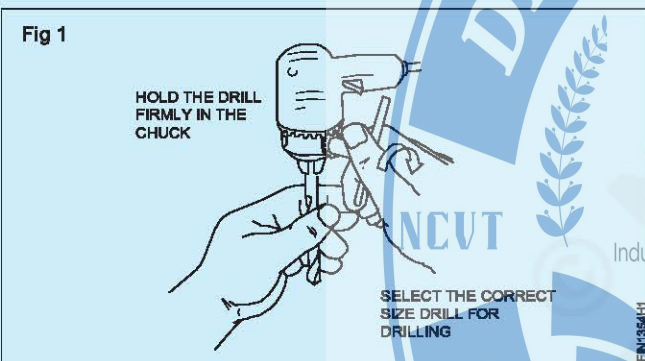

Before inserting the drill in the drill chuck of the power operated portable drilling machine, be sure that the switch is off and earthing is provided.

Place the workpiece on a suitable wooden support and clamp with the help of a 'C' clamp. (Fig 2)

Hold the portable drilling machine in one hand and grasp the gun with fore finger and thumb of the other hand, such that the drill is perpendicular to the surface of the metal to be drilled. (Fig 2)

Switch 'ON' the trigger switch with second finger.

Apply pressure on the drilling machine till hole is drilled.

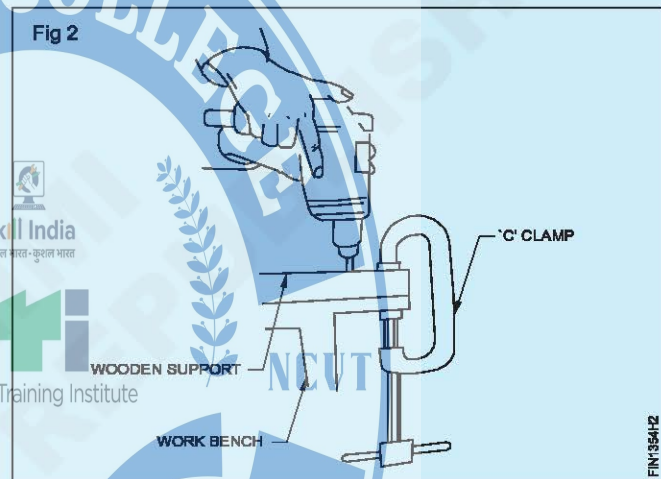

While drilling by electric operated portable drilling machine on a sheet metal, light pressure should be applied otherwise, the drill will get struck to the workpiece. (Fig.3)

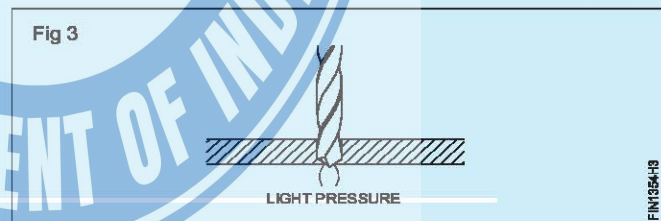

Switch off the drilling machine after the drilling is completed.

De-burr the holes by larger sized drill by rotating it on the drilled hole by hand.

Riveting with as many types of rivet as available, use of counter sunk head rivets

Objectives: At the end of this exercise you shall be able to

- mark and drill hole for riveting as per drawing
- rivet counter sunk head rivet, flat head rivet, snap head rivet and pan head rivets.

TASK 1

RIVETING WITH COUNTERSUNK HEAD RIVET

TASK 2

RIVETING WITH FLAT HEAD RIVET

2	ISSH 50 x 48x 1.2	-	G.I SHEET	-	TASK2	-
2	ISSH 50 x 48x 1.2	-	G.I SHEET	-	TASK 1	1.3.55
NO.OFF	STOCK SIZE	SEMI-PRODUCT	MATERIAL	PROJECT NO.	PART NO.	EX. NO.
<p>SCALE 1:1</p>					<p>DEVIATIONS ±0.5mm TIME :</p>	
<p>RIVETING WITH TYPES OF RIVETS (COUNTER SUNK HEAD AND FLAT HEAD RIVETS)</p>					<p>CODE NO. FI20N1355E1</p>	

TASK 3

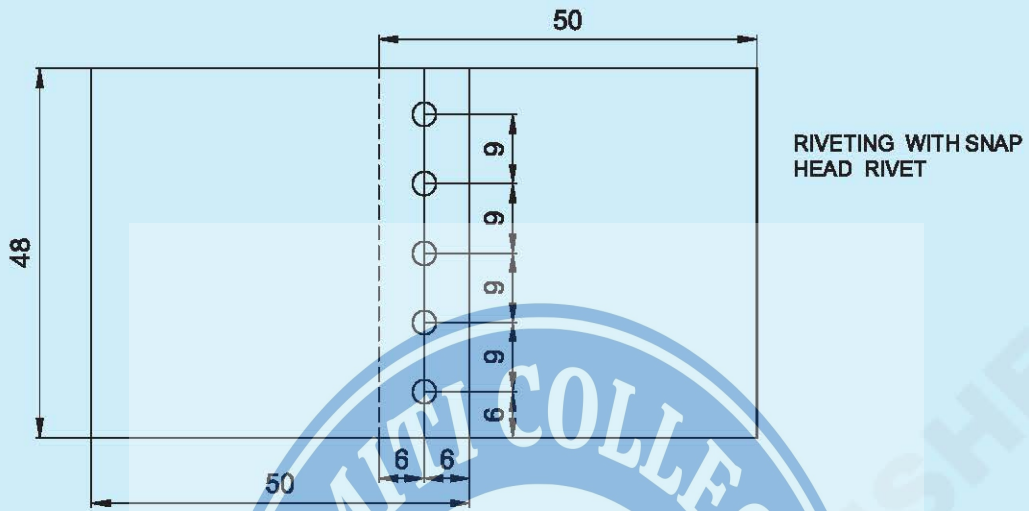
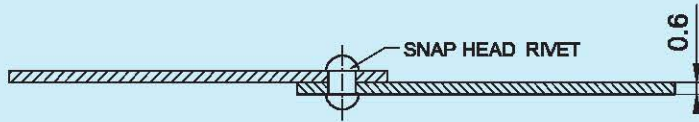

TASK 4

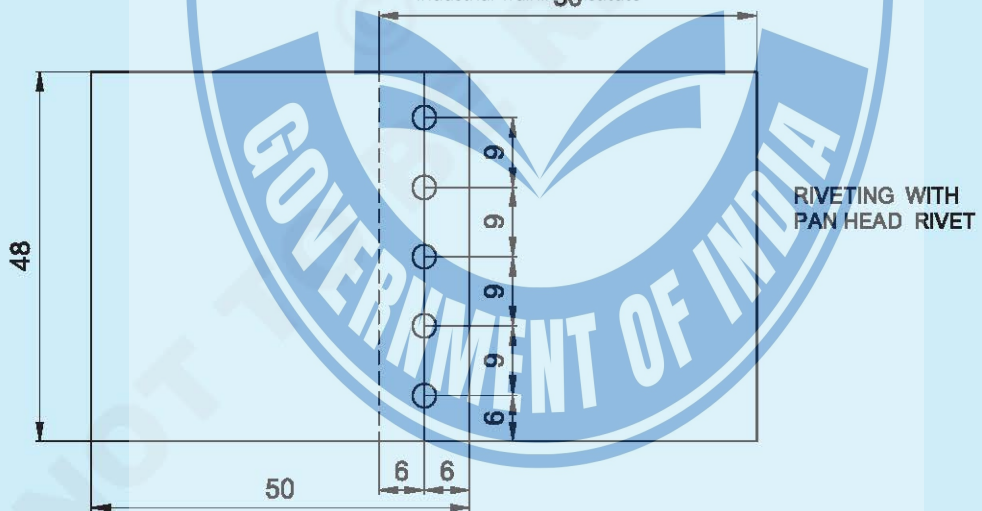

SCALE 1:1

RIVETING WITH MANY TYPES OF RIVETS
(SNAP HEAD AND PAN HEAD RIVETS)

DEVIATIONS ±0.5

TIME:

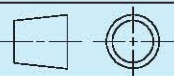

CODE NO. F120N1355E2

Job Sequence

- Check the size of sheets 50x48mm using a steel rule.
- Flatten the sheets on dressing plate using mallet.
- Mark and drill holes as per drawing.
- Place the piece of sheet having all holes drilled above another, such that the overlapped edges of the sheets coincide with the marked lines.
- Align the drilled holes in centre.
- Insert 3mm dia counter sunk head rivet in the centre hole. (Fig.1)
- Form the rivet head with the help of a rivet set using a ball pein hammer.
- Drill the remaining holes on the bottom piece of sheet through the holes, already drilled on the upper piece of sheet.
- Deburr the holes with larger sized drill, rotating it on the drilled holes by hand.
- Insert the rivets in alternate holes and form the rivet heads one by one to make single riveted lap joint (chain) with the help of a rivet set, and a ball pein hammer.
- Similarly, drill and rivet using flat head rivet in TASK 2, snap head rivet in TASK 3 and pan head rivet in TASK 4 and complete the riveting.

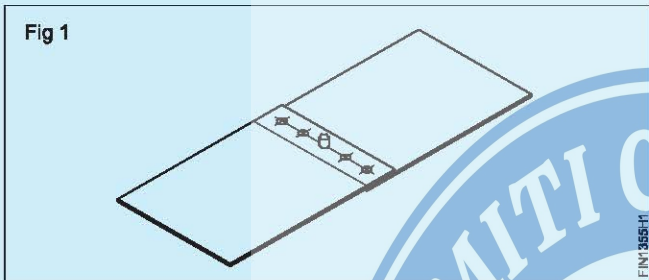

To form countsunk head rivet, pan head rivet, snap head rivet and flat head rivet, use dressing plate, rivet set, rivet snap and a ball pein hammer and complete the riveting.

