

**Mass, Weight, Volume and Density - Mass, volume, density, weight and specific gravity**

**Mass**

Mass of a body is the quantity of matter contained in a body. The unit of mass in F.P.S system is pound (lb), in C.G.S. system gram (gr) and in M.K.S and S.I systems kilogram (kg). 1 ton which is 1000 kg is also used sometimes. The conversion factor is 1000. Three decimal places are shifted during conversion. E.g. 1 ton = 1000 kg 1g = 1000mg.

m - mass of a body

g - acceleration due to gravity in metre/sec<sup>2</sup> = 9.81 m/sec<sup>2</sup>

V - volume of the body

ρ - density (pronounced as 'rho')

W or FG - weight or weight force

**Mass (Fig 1)**

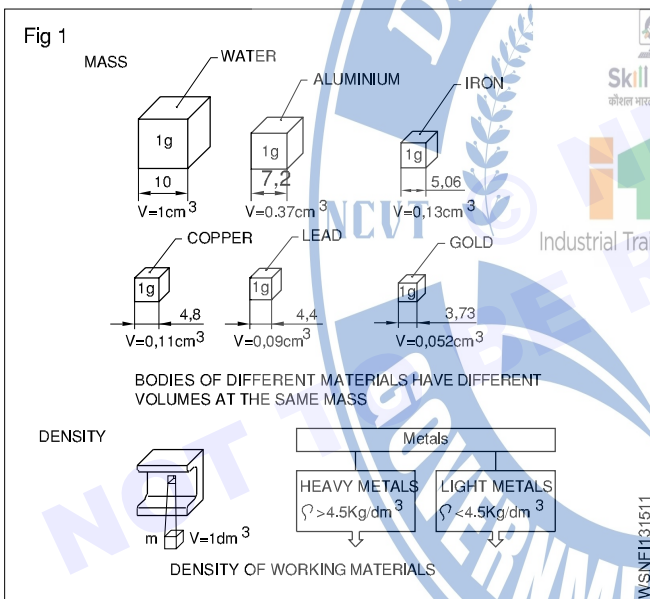

**Weight (Fig 2)**

Weight is the force with which a body is attracted by the earth towards its centre. It is the product of the mass of the body and the acceleration due to gravity. The weight of a body depends upon its location.

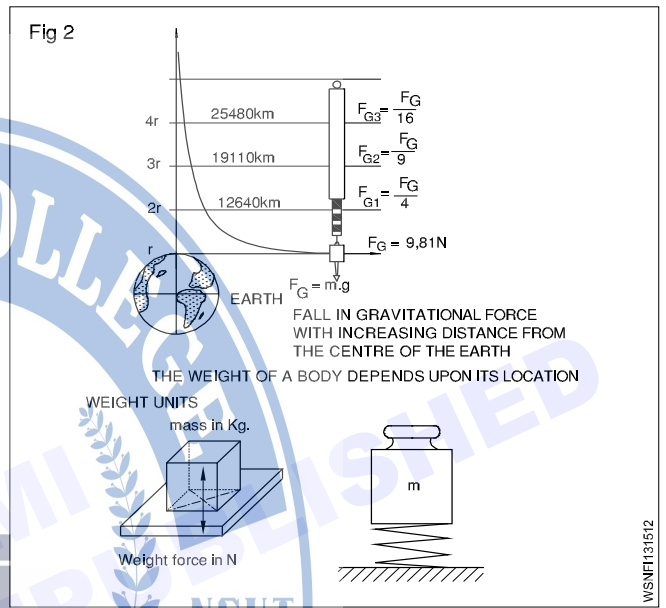

weight = W or FG = mass x gravitational force = m x g

System	Absolute unit	Derived unit	Conversion
F.P.S. system	1 poundal	1 Lb wt	32.2 poundals (1 lb x 1 ft/sec <sup>2</sup> = 1 pound)
C.G.S. system	1 dyne 1 gr x 1 cm/sec <sup>2</sup>	1 Gr.wt	981 dynes
M.K.S.	Newton	1 kg.wt	1 Newton =
S.I.system	Newton	Newton	1 kg x 1 m/sec <sup>2</sup>

**1 kg.wt = 9.81 Newton (approximately 10N)**      **1 Newton = 10<sup>5</sup> dynes.**

**Density**

Density is the mass of a body per unit volume. Hence its unit will be gr/cm<sup>3</sup> or kg/dm<sup>3</sup> or ton/m<sup>3</sup>.

Density =  $\frac{\text{mass}}{\text{volume}} = \frac{m}{v} = \rho$

## Difference between mass and weight

S. No	Mass	Weight
1	Mass is the quantity of matter in a body (ie) measurement of matter in a body	Weight is measure of amount of force acting on mass due to acceleration due to gravity
2	It does not depend on the position or space	It depends on the position, location and space
3	Mass of an object will not be zero	Weight of an object will be zero if gravity is absent
4	It is measured using by physical balance	It is measured using by spring balance
5	It is a scalar quantity	It is a vector quantity
6	When immersed in water mass does not change	When immersed in water weight will change
7	The unit is in grams and kilogram	The unit is in kilogram weight, a unit of force

**Mass and weight are different quantities.**

**Mass of a body is equal to volume x density.**

**Weight force is equal to mass x acceleration due to gravity.**

## Weight , Density and Specific gravity

It is now seen that the mass of a substance is measured by its weight only without any reference to volume. But if equal weights of lead & aluminium, are compared the volume of lead is much smaller than volume of aluminium. So we can now say that lead is more dense than aluminium, .i.e In other words the density of lead is greater than aluminium. (Fig 3 & 4)

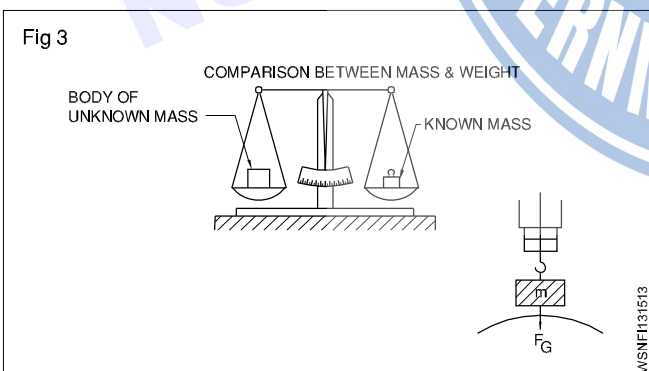

The relation of mass and volume is called density.

The density expresses the mass of volume E.g. 1 dm<sup>3</sup> of water has the mass of 1kg - thus the density of 1kg/dm<sup>3</sup> (Fig 2)

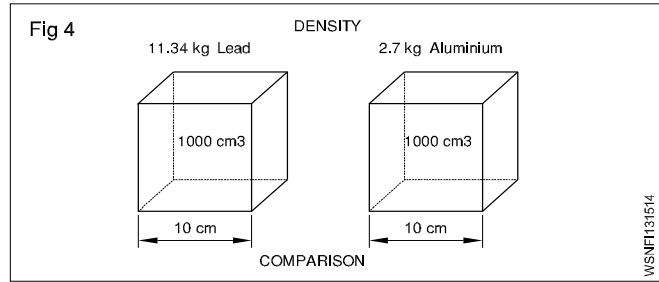

## Unit

The density is measured as below

MKS/SI= Kg/m<sup>3</sup>, CGS - 1 gm/cm<sup>3</sup> FPS–lbs/c ft

Solids	gm/cc	Liquids	gm/cc
1 Aluminum	2.7	Water	1.00
2 Lead	11.34	Petrol	0.71
3 Cast iron	6.8 to 7.8	Oxygen	1.43
4 Steel	7.75 to 8.05	Diesel Oil	0.83

The specific gravity of a substance is also called its relative density.

Formula

$$\text{Specific gravity (or) Relative density} = \frac{\text{Density of the substance}}{\text{Density of the water at } 4^{\circ}\text{C}}$$

$$= \frac{\text{Mass of any volume of a substance}}{\text{Mass of an equal volume of water at } 4^{\circ}\text{C}}$$

## Comparison Between Density And Specific Gravity (Relative Density)

Density	Relative density or Specific gravity
Mass per unit volume of a substance is called its density Its unit is gm per cu cm; lbs per cu.ft and kg/cubic meter	The density of substance to density of water at 4°C is its relative density It has no unit of measurement simply expressed in a number
$\text{Density} = \frac{\text{Mass}}{\text{Volume}}$	Relative density $= \frac{\text{Density of the substance}}{\text{Density of water at } 4^{\circ}\text{C}}$

Solids	Sp.gy	Liquids	Sp.gy
1 Aluminium	2.72	Petrol	0.71
2 Lead	11.34	Battery acid	1.2 to 1.23
3 Cast iron	6.8 to 7.8	Water	1.00
4 Steel	7.82	Diesel Oil	0.83

From the above table, we can calculate the weight of any given volume of a substance (say Diesel oil) in any units provided we know the specific gravity of the substance. Also vice-versa for volume of density is known.

**Mass, Weight, Volume and Density - Related problems for mass, volume, density, weight and specific gravity**

1 Calculate the mass in kg of a rectangular steel plate of dimensions 220 x 330 x 15 mm (Fig 1) (density of steel = 7.82 gm/cm<sup>3</sup>)

Mass = Volume x density  
 = 22 x 33 x 1.5cm x 7.82 gm/cm<sup>3</sup>  
 = 1089 cm<sup>3</sup> x 7.82 gm/cm<sup>3</sup>  
 mass = 8.516 kg

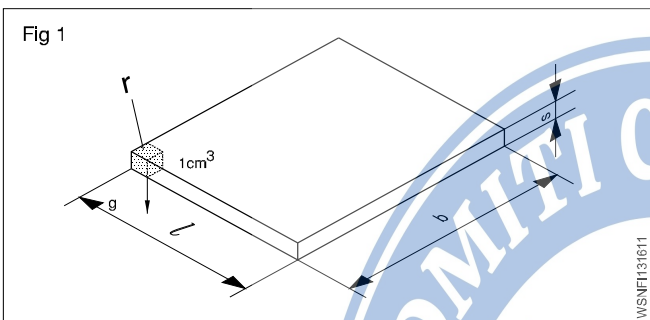

2 What is the weight in Newton if a storage container holds 250 litres of water and amount of water exert on the surface which it is standing? (Fig 2)

( 1 litre of water = 1 kg of water )  
 Density of water 1 gm/cm<sup>3</sup> or 1 kg/dm<sup>3</sup>

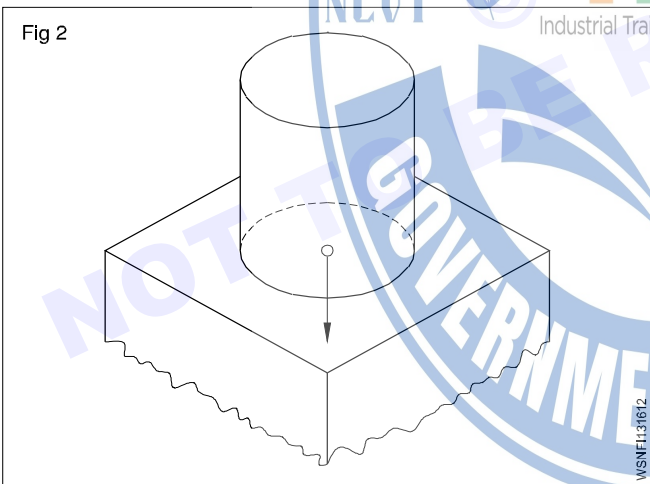

**Acceleration due to gravity is taken as 10 metre/sec<sup>2</sup> (approximation).**

Capacity = 250 litres = 250 dm<sup>3</sup> in volume.  
 Mass of water = volume x density of water  
 = 250 dm<sup>3</sup> x 1 kg/dm<sup>3</sup> = 250 kg  
 Weight extended = mass x acceleration due to gravity  
 = 250 kg x 10 metre/sec<sup>2</sup>  
 = 2500 kg.metre/sec<sup>2</sup> = 2500 N (∵ 1 kg.m/sec<sup>2</sup>=1N)

3 A force of 15 dynes acting on a mass of 'm' produces an acceleration of 2.5 cm/sec<sup>2</sup>. Find the mass.

1 Gr. wt. = 981 dynes

∴ 15 dynes =  $\frac{15}{981}$  Gr.wt

Force = m x acceleration produced by the force

∴ Gr.wt = mass x 2.5 cm/sec<sup>2</sup>

∴ gr.cm/sec<sup>2</sup> = mass x 2.5 cm/sec<sup>2</sup>

∴ mass =  $\frac{15}{981 \times 2.5}$  grams =  $\frac{\text{gm.cm/sec}^2}{\text{cm/sec}^2}$

mass = 0.00612 gram

4 A force of 2 N acts on a mass of 10 kg. Find the acceleration produced by the force on the mass.

Force = 2 N (∵ 1 N = 1kg.m/sec<sup>2</sup>)

Force = mass x acceleration

∴ 2 kg.metre/sec<sup>2</sup> = 10 kg x acceleration produced

∴ 2 x 1 kg.metre/sec<sup>2</sup> = 10 kg x acceleration produced

∴ acceleration produced =  $\frac{2}{10}$  metre/sec<sup>2</sup>

= 0.2 metre/sec<sup>2</sup>

5 Calculate the weight of a body having a mass of 1 kg if the acceleration due to gravity is 9.81 metre/sec<sup>2</sup>

Weight force = mass x acceleration due to gravity  
 = 1 kg x 9.81 metre/sec<sup>2</sup>

(1 kg.metre/sec<sup>2</sup> = 1 N)

∴ 9.81 kg metre/sec<sup>2</sup> = 9.81 N

**In the examples solved the value of 'g' is taken as 10 metre/sec<sup>2</sup>, unless specifically mentioned otherwise.**

• The outside and inside diametres of a hollow sphere are 150 & 70mm respectively. Calculate its mass if the density of material is 7.5 gm/cm<sup>3</sup>. (Fig 3)

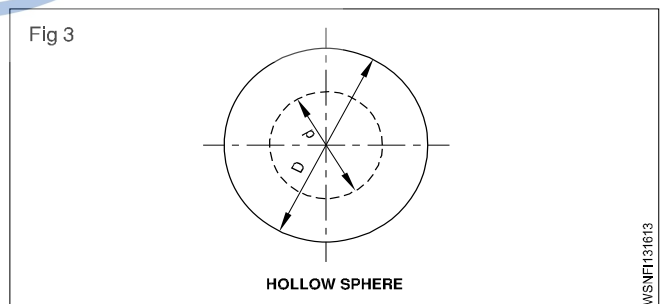

Mass = Volume x Density

= Volume x 7.5 gm/cm<sup>3</sup>

D= 150 mm = 15cm R= 7.5 cm

$$d = 70\text{mm} = 7 \text{ cm} \quad r = 3.5 \text{ cm}$$

$$\text{Volume} = \frac{4}{3}\pi(R^3 - r^3)\text{unit}^3$$

$$= \frac{4}{3}\pi(7.5^3 - 3.5^3)$$

$$= 1587.5 \text{ cm}^3$$

$$\text{Mass} = 1587.5 \text{ cm}^3 \times 7.5 \text{ gm/cm}^3$$

$$= 11906.6 \text{ gm} = 11.9 \text{ kg} \quad \text{say } 12 \text{ kg}$$

6 A car has a mass of 800 kg. Find out its weight force (Take 9.81 m/sec<sup>2</sup>)

$$(\because 1 \text{ n} = 1 \text{ kg.m/sec}^2)$$

The Wt. force of a car = Mass of car x gravitational acceleration

$$= 800 \times 9.81 \text{ N}$$

$$= 7848 \text{ Newtons}$$

7 A cylindrical tank 2m dia x 3.5 m length is filled with petrol. Find the weight of petrol in Tonnes, Assume density of petrol 720 Kg/m<sup>3</sup>. (Fig 4)

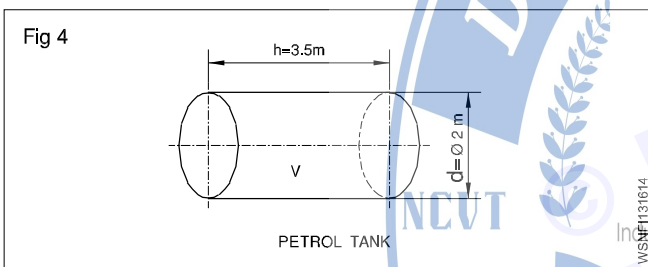

Volume of Tank

$$v = \pi r^2 l \text{ (or)} \frac{\pi d^2}{4} \times l \text{ unit}^3 = \frac{\pi \times 2^2}{4} \times 3.5 \text{ m}^3$$

$$3.14 \times 3.5 \text{ m}^3 = 10.99 \text{ m}^3$$

$$\text{Since } 1 \text{ m}^3 = 1000 \text{ litres}$$

$$\text{Volume of Tank} = 10.99 \times 1000 \text{ litres}$$

$$\text{Density of petrol} = 720 \text{ Kg/m}^3.$$

$$\begin{aligned} \text{Weight of Petrol in Kg} &= 10.99 \times 1000 \text{ litres} \times 720 \text{ Kg} \\ &= 720 \times 10990 \text{ Kg} \end{aligned}$$

Weight of Petrol in Tonnes

$$\text{(Metric Units)} = \frac{720 \times 10990}{1000}$$

$$\text{Weight of Petrol} = 7912.8 \text{ Tonnes}$$

8 If the battery acid specific gravity is 1.3, and this is being filled up into a cylindrical tank. Find out its density.

$$\text{(Density of water} = 1000 \text{ gm/cm}^3)$$

Specific gravity or Relative density

$$= \frac{\text{Density of the substance}}{\text{Density of water at } 4^\circ\text{c}}$$

Now, density of battery acid

$$= \text{Specific gravity} \times \text{Density of water}$$

$$= 1.3 \times 1000 \text{ gm/cm}^3$$

$$= 1300 \text{ gm/cm}^3$$

### Determination of specific gravity of a substance

The specific gravity of a substance may be determined by

1 Archimedes Principle

2 Hydrometer

### Archimedes Principle

Archimedes principle states that when a body is fully or partially immersed in a liquid, the amount of liquid displaced by the body is equal to the loss of weight of the body in the liquid.

Weight of a body in a liquid = total weight of the body

- weight of the liquid displaced by the body

This quantity if it is zero then the body will float. It is negative the body will rise up till the weight of liquid displaced by the immersed portion of the body is equal and equal to the weight of the body. If it is positive the body will sink. Specific gravity of solids soluble in water

Skill India

कोशल भारत - कुशल भुक्त

weight of solid in air

loss of weight of solid in water

specific gravity of solids soluble in water

weight of solid in air x specific gravity of the liquid

loss of weight of solid in which the solid is in solution

specific gravity of a liquid

loss weight of a solid in water

loss of weight of the same solid in liquid

**The solid chosen should be such that it is insoluble in both water and the liquid whose specific gravity is to be determined.**

### Example

1 An iron piece weighs 160 kgf in air and 133 kgf when it is fully immersed in water. Determine the volume and specific gravity of the iron piece.

$$\text{Weight of the solid in air} = 160 \text{ kgf}$$

$$\text{Weight of the solid in water} = 133 \text{ kgf}$$

$$\therefore \text{Loss of weight in water} = 27 \text{ kgf}$$

By Archimedes principle the loss of weight of a solid in water = volume of water displaced.

$$\therefore \text{Volume of water displaced} = 27 \text{ cm}^3$$

$$\therefore \text{Volume of the solid} = 27 \text{ cm}^3$$

$$\text{Density of the iron piece} = \frac{\text{mass of iron}}{\text{volume of the piece}}$$

$$= \frac{160}{160 - 133} = \frac{160}{27} = 5.93$$

$$\text{Specific gravity} = \frac{\text{density of iron}}{\text{density of water}} = \frac{5.93}{1} = 5.93$$

Specific gravity of iron piece = 5.93

- 2 A metal piece weighs 6.5 kgf in air and 3.5 kgf in water. Find its weight when it is fully immersed in a liquid whose specific gravity is 0.8 and also the S.G of the metal.

Weight of metal piece in air = 6.5 kgf

Weight of metal piece in water = 3.5 kgf

$$\therefore \text{Loss of weight in water} = 3.00 \text{ kgf} (6.5 - 3.5)$$

$\therefore$  Specific gravity of metal

$$= \frac{\text{Weight of substance in air}}{\text{Loss of weight in water}} = \frac{6.5 \text{ kgf}}{3 \text{ kgf}} = 2.166$$

By applying the principle of Archimedes the above results are derived.

The weight of the metal piece in the liquid = W

$$\therefore \text{loss of weight of the metal in the liquid} = 6.5 \text{ kgf} - W$$

$$\text{Specific gravity of the liquid} = \frac{\text{loss of weight in liquid}}{\text{loss of weight of water}}$$

$$\therefore 0.8 = \frac{6.5 \text{ kgf} - W}{3 \text{ kgf}}$$

$$\therefore W = 6.5 \text{ kgf} - 3 \text{ kgf} \times 0.8 = 4.1 \text{ kgf}$$

$$\therefore \text{loss of weight of the metal in the liquid} = 4.1 \text{ kgf.}$$

By using a hydrometer, the specific gravity of a liquid is determined. The most common type of hydrometer is the Nicholson's hydrometer which is a variable weight but constant immersion type.

Specific gravity of a liquid

wt. of hydrometer + wt. required to sink the hydrometer in the liquid to a fixed mark

wt. of hydrometer + wt. required to sink the hydrometer in water up to the same mark

- 3 A piece of wood having 80cc volume, when floated on water remains 60cc volume above water. Find the weight of the water displaced.

Water displaced = Immersed volume

Immersed volume = volume of wood - volume of wood above water level

$$= 80 - 60 = 20 \text{ c.c.}$$

Weight of water displaced = volume x density of water

$$= 20 \times 1 = 20 \text{ grams}$$

Sl.No	Substance	Density gm/cc
1	Aluminium	2.7
2	Cast Iron	6.8 - 7.8
3	Copper	8.92
4	Gold	19.32
5	Iron	7.86
6	Lead	11.34
7	Nickel	8.912
8	Silver	10.5
9	Steel	7.75 - 8.05
10	Tin	7.31
11	Zinc	7.14
12	Diamond	3.51
13	Bismuth	9.78
14	Brass	8.47
15	Phosphorus Bronze	8.7 - 8.9
16	Ice	0.93
17	Air	0.0013
18	Mercury	13.56
19	Petrol	0.71
20	Diesel	0.83
21	Kerosene	0.78 - 0.81
22	Water	1.0

# Assignment

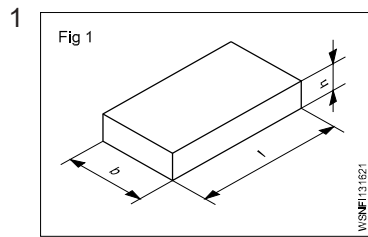

$l = 1800 \text{ mm}$   
 $b = 65 \text{ mm}$   
 $h = 12 \text{ mm}$   
 $\rho = 7.85 \text{ g/cm}^3$   
 $m = \text{_____ kg}$

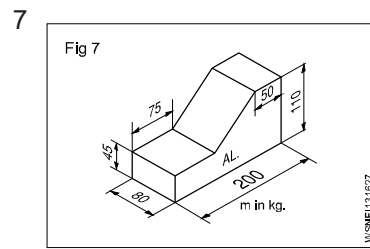

$L = 200 \text{ mm}$   
 $l_1 = 75 \text{ mm}$   
 $l_2 = 50 \text{ mm}$   
 $B = 80 \text{ mm}$   
 $H = 110 \text{ mm}$   
 $h = 45 \text{ mm}$   
 $\rho = 2.7 \text{ g/cm}^3$   
 $m = \text{_____ kg}$

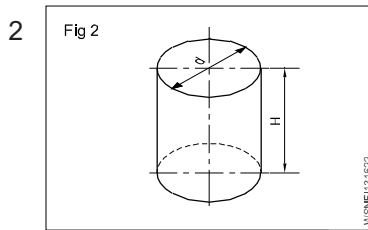

Capacity = 36 litres  
 $d = 32 \text{ cm}$   
 $H = \text{_____ cm}$

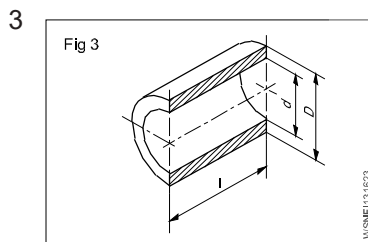

$D = 74 \text{ mm}$   
 $d = 68 \text{ mm}$   
 $l = 115 \text{ mm}$   
 $\rho = 8.6 \text{ g/cm}^3$   
 $m = \text{_____ gms}$

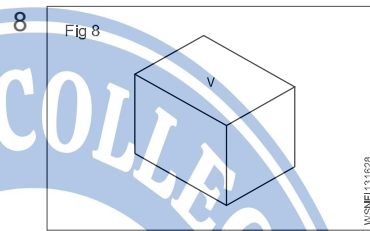

$V = 320 \text{ cm}^3$   
 $\rho = 8.9 \text{ g/cm}^3$   
 $g = 9.80665 \text{ metre/ sec}^2$   
 $m = \text{_____ kg}$   
 $FG = \text{_____ N}$

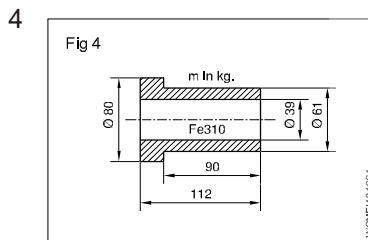

$D_1 = 80 \text{ mm}$   
 $D_2 = 61 \text{ mm}$   
 $d = 39 \text{ mm}$   
 $L = 112 \text{ mm}$   
 $l = 90 \text{ mm}$   
 $\rho = 7.85 \text{ g/cm}^3$   
 $m = \text{_____ kg}$

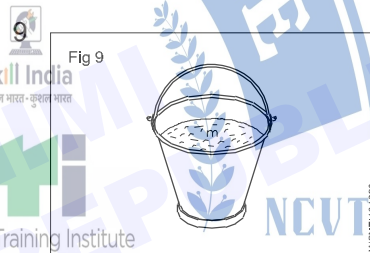

Capacity = 35 litres  
 $g = 10 \text{ metres/sec}^2$   
 $FG = \text{_____ N}$

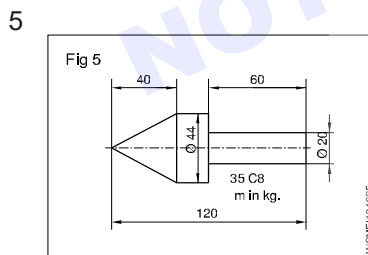

$D = 44 \text{ mm}$   
 $d = 20 \text{ mm}$   
 $L = 120 \text{ mm}$   
 $l_1 = 60 \text{ mm}$   
 $l_2 = 40 \text{ mm}$   
 $\rho = 7.85 \text{ g/cm}^3$   
 $m = \text{_____ kg}$

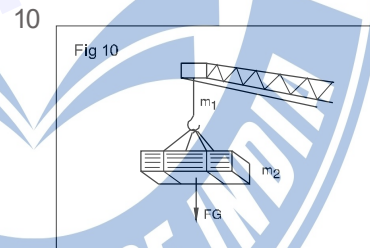

$(m_1)$  mass of chain = 150 kg  
 Total FG = 8 KN  
 Load = \_\_\_\_\_ N  
 mass  $m_2 = \text{_____ kg}$

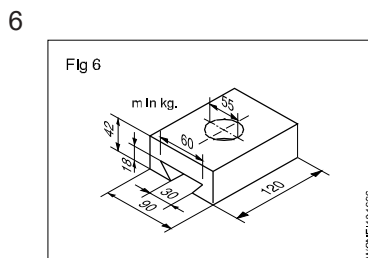

$L = 120 \text{ mm}$   
 $B = 90 \text{ mm}$   
 $b_1 = 60 \text{ mm}$   
 $b_2 = 30 \text{ mm}$   
 $d = 55 \text{ mm}$   
 $H = 42 \text{ mm}$   
 $h = 18 \text{ mm}$   
 $\rho = 7.85 \text{ g/cm}^3$   
 $m = \text{_____ kg}$

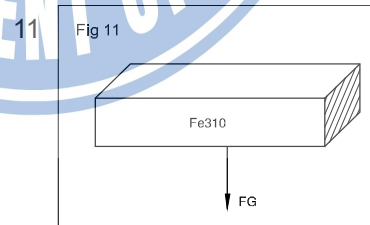

$W (FG) = 22.5 \text{ N}$   
 $V (\text{volume}) = \text{_____}$

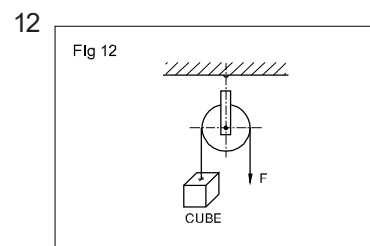

$F = 250 \text{ d N}$   
 side of cube = \_\_\_\_\_ mm  
 (cubical counter weight balances 'F')