

Identify parts and terminals of different types of single phase AC motors

Objectives: At the end of this exercise you shall be able to

- read and interpret the name plate details of the given single phase AC motors
- identify their parts and write their names
- identify the pairs of two windings of 3 terminals & four terminals of single phase motor
- measure the resistance of each winding by an ohmmeter.

Requirements	
Tools/Instruments	
• Trainee's tool kit	- 1 No.
• ohmmeter/multimeter	- 1 No.
Equipments/Machines	
• Induction start induction run motor 1/2 HP, 240V, 50Hz	- 1 No.
• Single phase capacitor start induction run motor 1HP, 240V, 50Hz	- 1 No.
• Universal motor 240V, 50Hz, 0.5HP	- 1 No.

PROCEDURE

TASK 1 : Identify the parts of single phase induction start motor / split phase motor

1. Read and interpret the name plate details of the single phase induction start induction run motor and note down in Table 1.

Table 1
Name-plate details

Manufacturer, Trade mark	Rated frequency
Type, model or serial number	Rated power
Type of current	Rating class
Function	Insulation class
	Rated currentamp
	Rated speedr.p.m
Rated VoltageVolts	Protection class

- 2 Identify the parts of single phase induction start induction run motor from the real objects or from the exploded view chart. (Fig 1).
- 4 Write the name of the parts of each labelled numbers tag in Table 2.

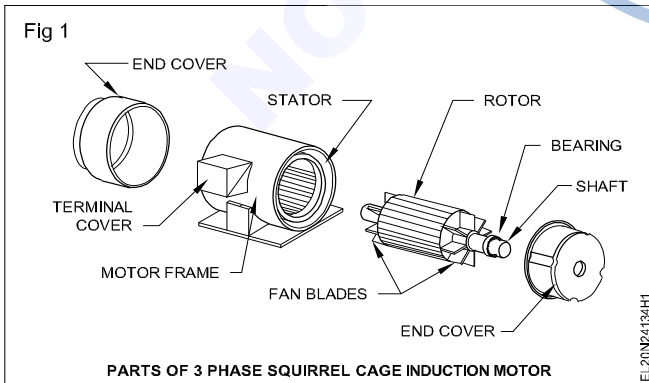

- 3 Label the each identified parts with number tags.

Table 2

SI No.	Label No.	Name of the parts
1		
2		
3		
4		
5		
6		
7		
8		

TASK 2 : Identify the parts of capacitor start induction run motor

- 1 Read and interpret the name details of the capacitor start, induction run motor
- 2 Identify the parts of the capacitor start, induction run motor from the real objects (or) from the exploded view Fig 1&2 and note down each labelled number in Table 1.

Table 1

SI No.	Label No.	Name of the parts
1		
2		
3		
4		
5		
6		
7		
8		

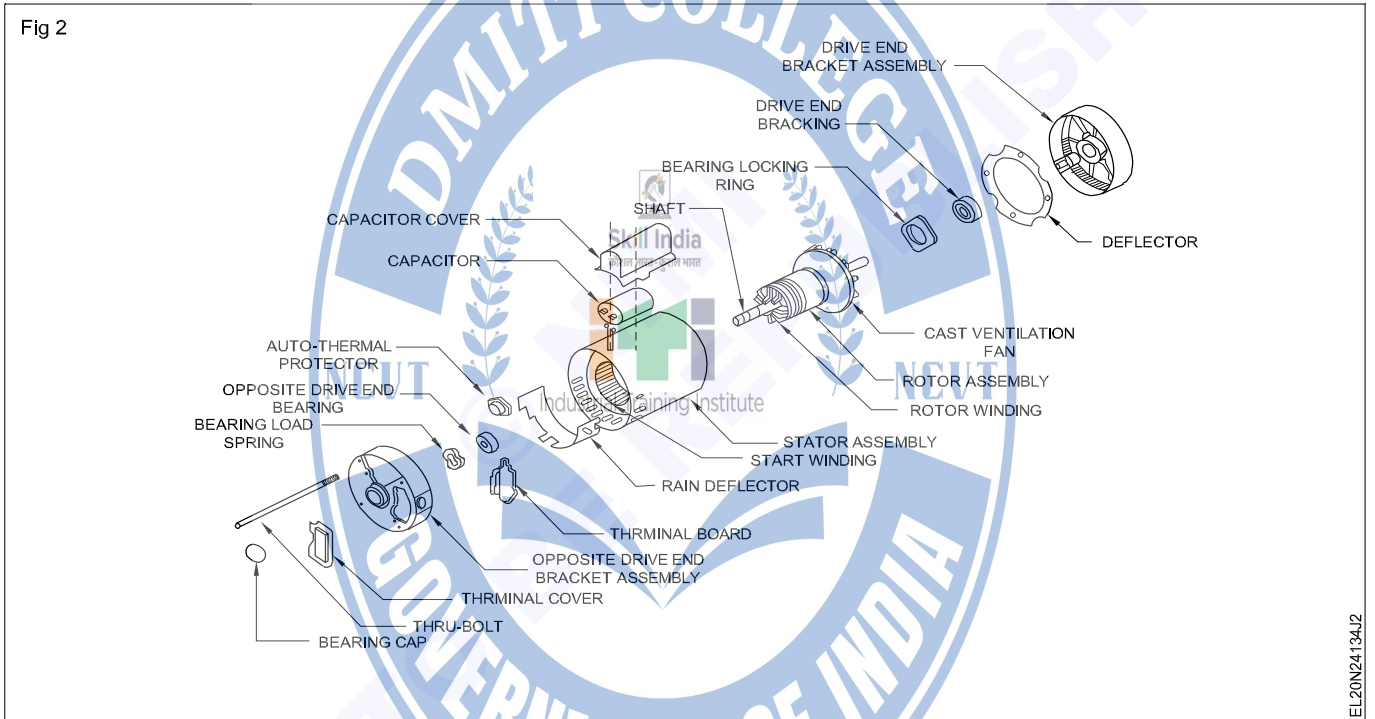
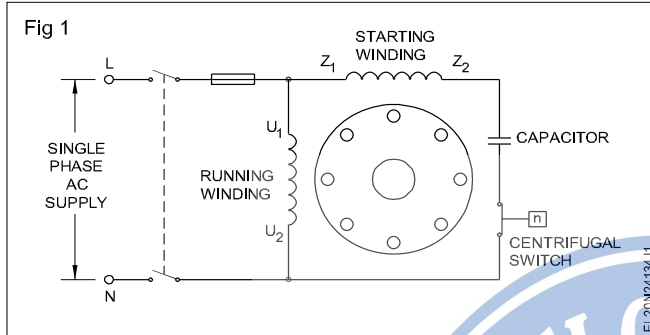

TASK 3 : Identify the parts of single phase capacitor start capacitor run motor/permanent capacitor motor

- 1 Read and interpret the name plate details of permanent capacitor motor.
- 2 Identify the parts of the permanent capacitor motor from the real objects (or) from the exploded view of Fig 1a and 1b and note down each labelled number in Table 1.
- 3 Get it checked with your instructor.

Table 1

SI No.	Label No.	Name of the parts
1		
2		
3		
4		
5		
6		
7		
8		

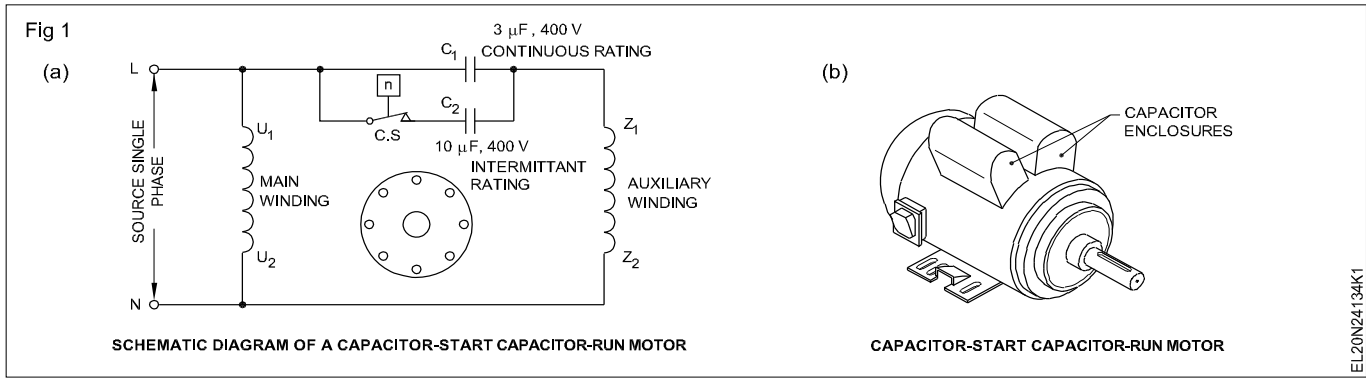

TASK 4 : Identify the parts of universal motor

- 1 Read and interpret the name plate details of the universal motor.
- 2 Identify the parts of the universal motor from the real objects (or) from the exploded view.(Fig 1)
- 3 Label the each identified parts with number tags.
- 4 Write the name of the parts of each labelled number tags in Table 1.

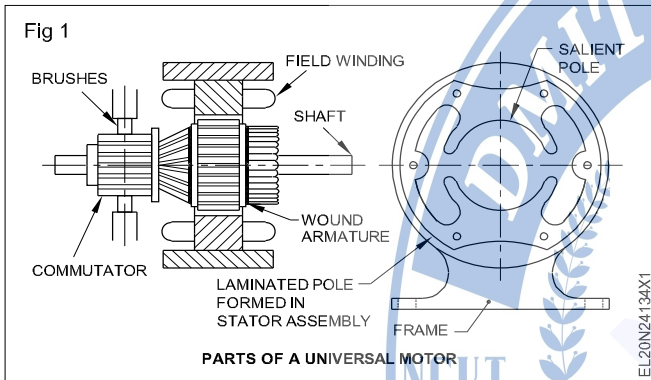

Table 1

Sl No.	Label No.	Name of the parts
1		
2		
3		
4		
5		
6		
7		
8		

5 Get it checked with your instructor.

TASK 5 : Identify 3 terminals of the pair of two windings of single-phase split phase induction motor

- 1 Remove the terminal cover. Make connection using a piece of cable and short circuit two terminals at a time to discharge the capacitor.
- 2 Remove the capacitor if any and test the capacitor for insulation and leakage.
- 3 Measure the resistance in between pairs of terminals by an ohmmeter. (Fig 1)
- 4 Mark the terminals between which you get maximum reading as 1 and 3. Mark the unmarked terminal as 2.
- 5 Record the resistance values in Table 1 according to your terminal marking made.

The reading between the pair of terminals 1 & 2 and 1 & 3, whichever is greater is considered as the terminals of starting winding and the other is considered as terminal of running winding.

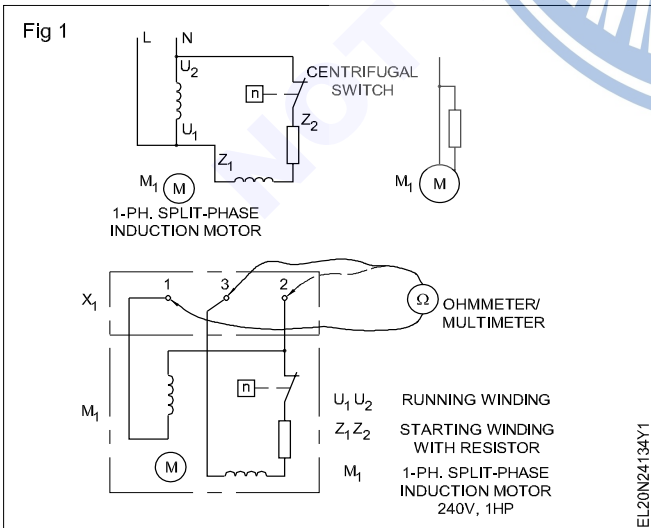

Table 1

Resistance between 1 & 2	Resistance between 2 & 3	Resistance between 1 & 3

TASK 6 : Identify 4 terminals of the pair of two windings of single phase split phase induction motor

- 1 Repeat the steps 1 and 2 of Task 5.
- 2 Find out the pairs of terminals and number one pair of terminals as 1 and 2. The other pair is numbered as 3 and 4 (Fig 1)
- 3 Measure the resistance between U1 and U2 and Z1 and Z2..

Conclusion

- 1 Higher resistance is between _____ terminals.
- 2 Lower resistance is between the terminals marked as _____

Therefore the starting winding is connected between _____

Resistance between 1 & 2 = _____ ohms

Resistance between 3 & 4 = _____ ohms

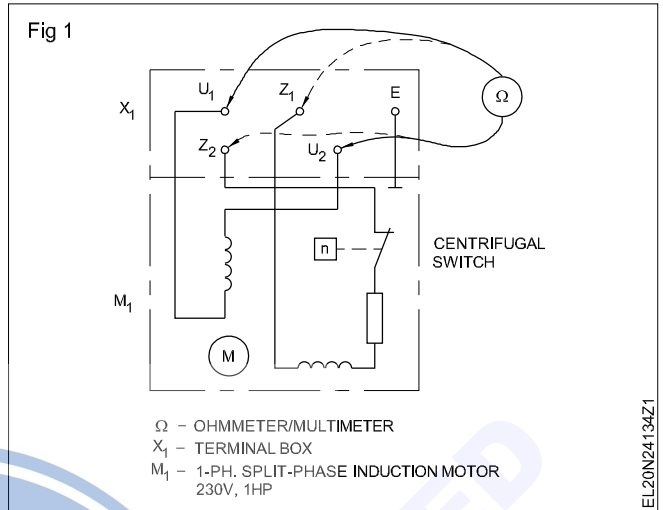

Install connect and determine performance of single phase AC motor

Objectives: At the end of this exercise you shall be able to

- read the manufacturer’s installation instruction and follow the same
- transfer the template measurements to the mounting base
- make the template of the base (mounting) of the given motor
 - frame (wooden)making
 - marking
 - drilling
 - selecting hole size.

Requirements	
Tools/Instruments <ul style="list-style-type: none"> • Masonry tools like travel spirit level etc- 1 Set • Drilling machine Electric 12.7 mm capacity with drills - 1 No. • Measuring tape 3 meters - 1 No. • Electrician hand tool kit - 1 Set • Spanner set 5 mm to 30 mm - 1 Set • Ball pein hammer 500 g - 1 No. 	Equipments/Machines <ul style="list-style-type: none"> • A.C Single phase motor 0.5 HP 240V - 1 No. Materials <ul style="list-style-type: none"> • Connecting cables - as reqd. • Plywood 8 mm thick 40 x 30 cm - 1 No. • Nuts, grouting bolts - as reqd. • GI wire 14 SWG - 6 m

PROCEDURE

TASK 1: Installation of single phase AC Motors

- 1 Read the name plate details and record in the motor maintenance card (Table 1)

Table 1

Name-plate details

Voltage _____	Phase _____	Type _____
Rating _____	Speed _____	
Power factor _____	Current _____	
SL No. _____		

- 2 Make necessary arrangements at the place where the motor is to be installed as per manufacturer’s nuts and bolts or / and R.C.C. foundation etc.
- 3 Determine the size of the connecting cable and fuse from the rating of the motor. (Table 2)

Fuse current rating will be 3 or 2 times more than running current. If it has the dual function of overload protection also, the rating should be as recommended by the manufacturer or as per I.S recommendations.

- 4 Cut two straight pieces and two cross pieces of plywood as shown in Fig 1 and mark the holes accordingly to the size of the holes of the base of the motor on the wooden frame planks (Fig 1)



Table 2

Calculating fuse ratings of motors

Motor type	Multiply the running current of the motor by
Single phase Squirrel-cage, full voltage start	3
Squirrel-cage, reduced voltage start or high-reactance type (if motor is rated at 30 ampere's or less)	3

- 5 Select the size of the drill according to the size of the mounting bolt as recommended by the manufacturer.
- 6 Drill the holes according to the size mentioned.
- 7 Make use of the template measurements on the mounting base and get the base mounting ready for installing the motor. (Fig 2)
 - a) Fix the planks with a grouting bolt.
 - b) Check for level using the spirit level.
 - c) Fill the space around the bolts with thin coarse cement mortar.

Fig 1

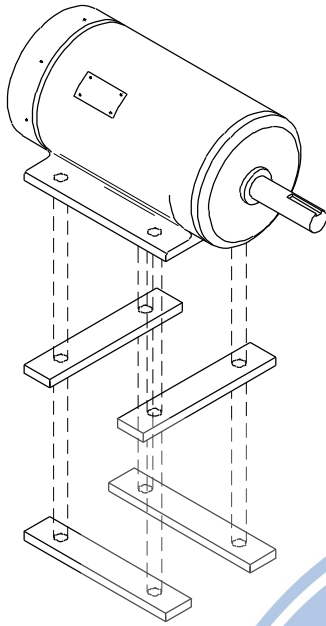

EL20N24135H1

In the training institute use clay mortar instead of cement to facilitate repetition easily by every trainee in a batch.

- d) Allow it to settle down for 8 to 12 hours, then remove the template planks.
- e) Cure the cement mortar with water for a minimum of 2 days
- f) Finish the surface by plastering neatly.

Include vibration arresting devices as per the manufacture's instructions such as spring washers etc.

- 8 Install the motor and fix it with nuts (Fig 3)
- 9 Make double earthing in accordance with I.E. regulations and I.S. recommendation.

Fig 2

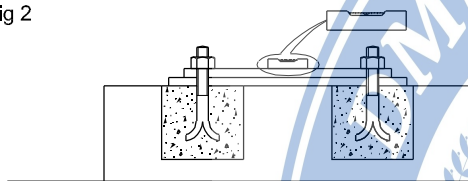

SECTION AT AA

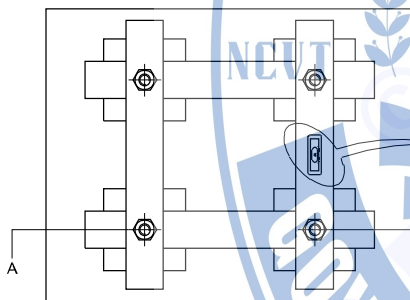

PLAN



Skill India
कौशल भारत कुरुल भारत

Industrial Training Institute

EL20N24135H2

Fig 3

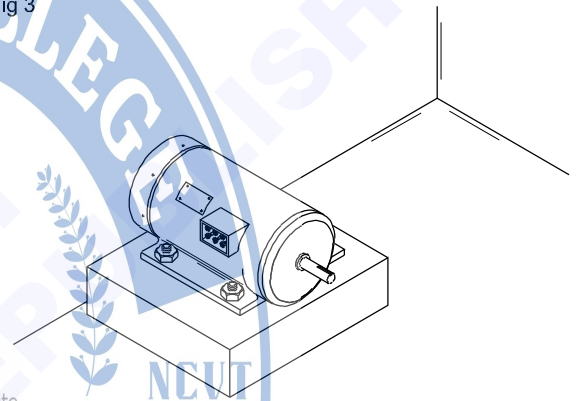

EL20N24135H3

- 10 Start the motor and observe any mechanical vibrations are there or not.
- 11 If any mechanical vibrations is there, then stop the motor and tighten nuts properly.

Start run and reverse the direction of rotation of single phase AC motors

Objectives: At the end of this exercise you shall be able to

- start run and reverse the D.O.R of induction start, induction run motors through DOL starter
- start run and reverse the D.O.R of capacitor-start, induction run motors
- start run and reverse the D.O.R of capacitors start, capacitor - run motor.

Requirements

Tools/Instruments

- Trainee's tool kit - 1 No.
- Pulley puller 15 cm - 1 No.
- MI Voltmeter 0-300V - 1 No.
- MI Ammeter 0-10 A - 1 No.
- Megger 500 V - 1 No.
- Ohmmeter - 1 No.

Equipment/Machines

- Single phase induction start, induction run motor 1/2HP, 250V, 50Hz - 1 No.
- D.O.L starter for single-phase motor 10A, 250V - 1 No.

- Capacitor start , induction run motor 250v, 50Hz, 1Hp - 1 No.
- Capacitor start, capacitor run motor 250V, 0.5 HP, 50Hz - 1 No.
- Regulated power supply (0.30v) - 1 No.

Materials

- GI wire 14 SWG - 6 m
- 2.5 sq. mm. PVC copper wire 250 V grade - as reqd.
- I.C.D.P. switch 16 A, 250V - 1 No.
- Fuse wire 10A - 10 gm



PROCEDURE

TASK 1 : Start , run and reverse the D.O.R of Induction start induction run motor through D.O.L Starter

1 Draw the complete connection diagram of the given motor, starter and I.C.D.P. (Fig 1)

- 2 Get the diagram approved by your instructor.
- 3 Connect the motor through the I.C.D.P. switch and starter as per the approved diagram across the AC rated voltage supply. Provide earth connection to the motor, the starter and the switch.
- 4 Replace with a fuse of proper capacity according to the motor rating and set the overload relay of the D.O.L. starter to the current rating of the motor.
- 5 Switch on the I.C.D.P. switch and press the start-button of the starter.
- 6 Check the direction of rotation and record it below. The direction of rotation is
- 7 Stop the motor by pressing the stop-button; switch off the I.C.D.P and remove the fuses.

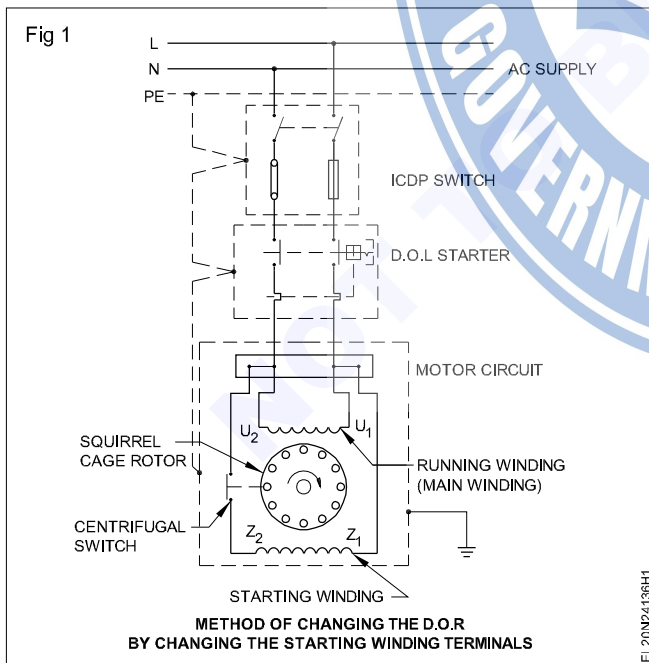

The I.C.D.P. switch must be switched off and the fuses removed before any modification in the circuit is carried out.

For changing the direction of rotation

8 Change the connection of the starting winding (Fig 2) and record it below. Direction of rotation is

9 Stop the motor and interchange the connection of the main field winding.

The D.O.R is

10 Stop the motor and switch off the supply.

Conclusion

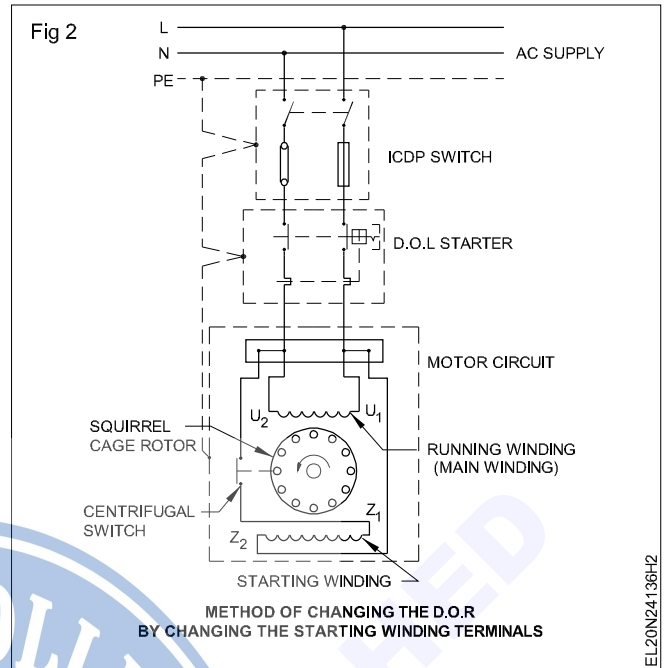

TASK 2 : Start run and reverse the D.O.R of single phase capacitor start induction run motor

1 Make the connection as per the circuit diagram. (Fig 1) Earthing the I.C.D.P. switch, starter and motor is most essential.

2 Provide fuse-wire, according to the rating of the motor, in the I.C.D.P. switch and set the overload relay ampere in the D.O.L. starter to the rated value of the motor.

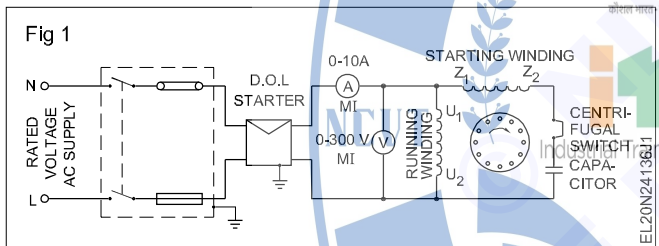

3 Switch 'ON' the I.C.D.P.

4 Start the motor with the help of the starter and note the starting current, normal running current and the direction of rotation, and enter the details in Table 1.

Table 1

Sl.No.	Reference circuit diagram	Starting current	Running current	Direction of rotation
1				
2				
3				

For changing the direction of rotation

5 Stop the motor by the starter and switch 'off' the I.C.D.P., and remove the fuse-carrier.

(Fig 2). Switch 'ON' the motor. Check the effect on the direction of rotation and record the result in Table 2.

6 Interchange either the starting winding or the running winding terminals for changing the direction of rotation. Fig 4 illustrates the changing of the starting winding.

7 Replace the fuse-carrier, and then switch on and start the motor. Note down the direction of rotation in Table 1.

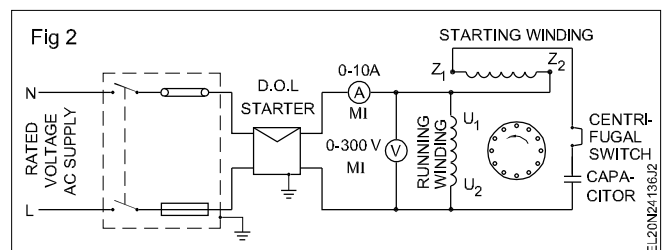

Effect of changing the supply leads

8 Switch off the motor and reconnect the winding. (Fig 1) Interchange the supply terminals as per circuit diagram.

The D.O.R changed / did not change with respect to the condition as per circuit (Fig 3).
(Strike out that part of the sentence which is not applicable).

Conclusion

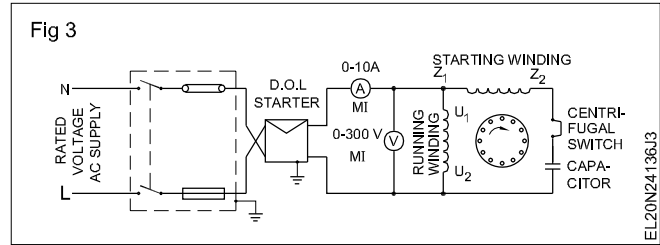

Table 2

SI.No.	Reference circuit diagram	Starting current	Running current	Direction of rotation
1				
2				
3				

TASK 3 : Start, run and reverse the direction of rotation of capacitor start capacitor run motors

- 1 Identify the starting and running condensers and check their condition and data. Enter them in Table 3. Compare and analyse the data also relating to the starting and running condensers.
- 2 Show the readings to your instructor and get his approval.
- 3 Check the condition of the centrifugal switch, and ensure it is working.

Table 3

SI.No.	Component part	Type	Value in micro-farad	Voltage		Duty Cycle	Condition
				Working	maximum		
1	Running capacitor						
2	Starting capacitor						

- 4 Connect the motor to the 240V AC supply through the switch and starter as per the circuit diagram. (Fig 1)
- 5 Insert a suitable size of fuse in the I.C.D.P switch and set the overload relay according to the rating of the motor.
- 6 Get the approval of your instructor for starting. Switch on the I.C.D.P and start the motor by pressing the start- button of the starter.
- 7 Check the direction of rotation and record the D.O.R below. Direction of rotation - clockwise/anticlockwise.

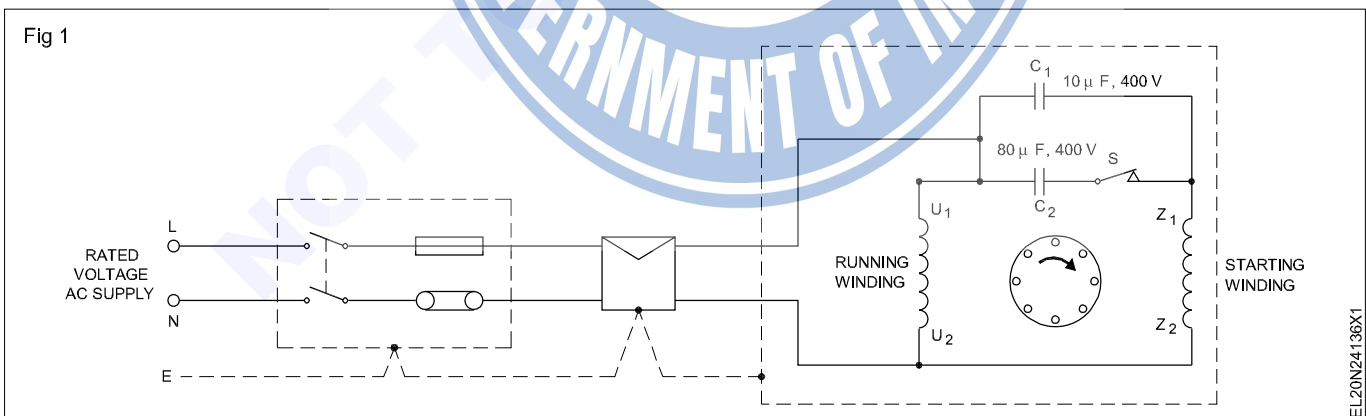

Change the direction of rotation of an AC single -phase capacitor, start capacitor-run motor.

For changing the direction of rotation

- 8 Stop the motor, switch off the I.C.D.P. Remove the fuse and interchange the running winding terminals. (Fig 2)

Fig 2

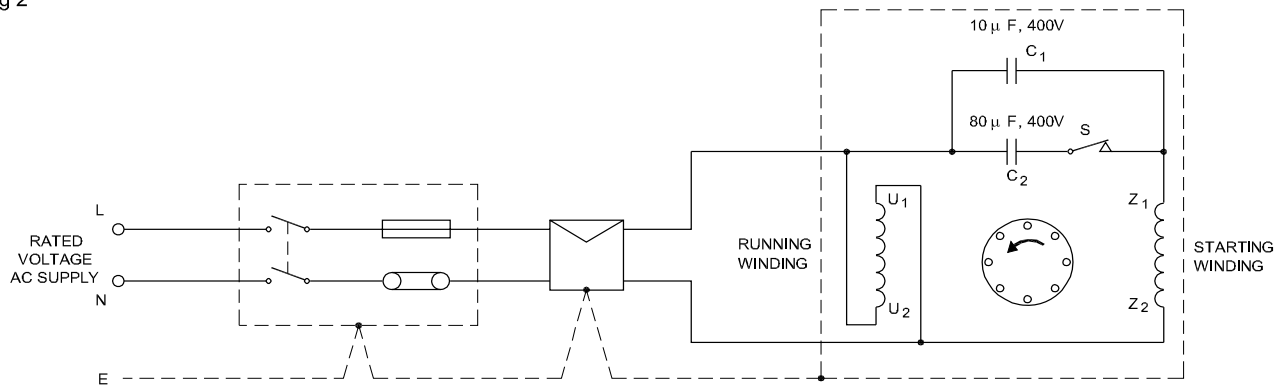

EL20N24136X2

9 Repeat the steps 6 and 7 of task 3.

The direction of rotation could be changed either by changing the running winding terminal connections or by changing the starting winding terminal connections whichever is easier. The schematic diagram shown in Fig 8 is for a four terminal machine. For a ten terminal machine only the terminal U_1 and U_2 can be changed easily.

10 Stop the motor, interchange the starting winding terminal connections as shown in Fig 3. Keeping the running winding connection as in Fig 1 and repeat the steps 5 to 6 of task 1.

11 Check the D.O.R is clockwise/ anticlockwise.

12 Stop the motor, reconnect the starting and running winding as in Fig 1. Only interchange the supply terminal connections at the starter outgoing side as shown in Fig 4 and repeat the steps 8 and 9 of Task 1.

13 The D.O.R. is clockwise /anticlockwise.

14 Stop the motor. Switch off the ICDDP. Remove the fuses. Disconnect the cables. Write your observation regarding the method of changing the direction of rotation and show to your instructor.

Conclusion

Fig 3

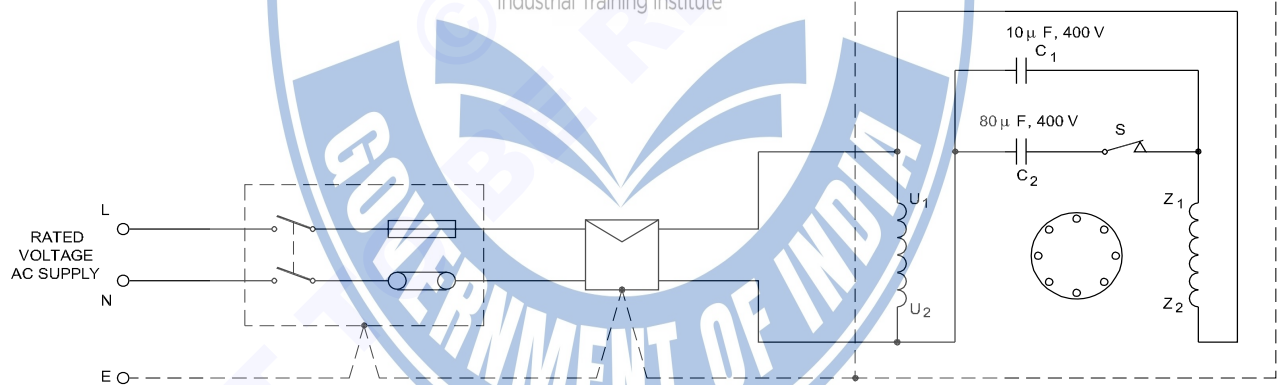

EL20N24136X3

Fig 4

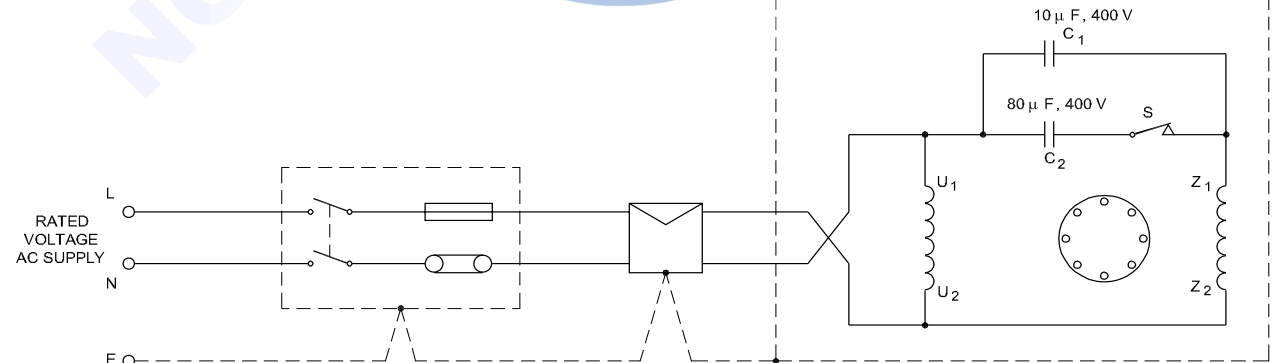

EL20N24136X4

Practice on speed control of a single phase AC motors

Objectives: At the end of this exercise you shall be able to

- interpret the name-plate details of an ac series motor and determine full load current
- select a suitable variable resistor
- connect, run and measure the speed for different settings of the resistor.

Requirements			
Tools/Instruments			
• Electrician tool Kit	- 1 No.	• Rotary switch 6A, 250.4 position	- 1 No.
• Voltmeter 0-300 V	- 2 Nos.		
• Ammeter 0 - 5A	- 1 No.	Materials	
• Tachometer 3000 rpm	- 1 No.	• Connecting cable	- as reqd.
		• ICDP switch 16A 250V	- 1 No.
		• Wire wound enamel insulated resistor 10 ohms 100 W	- 2 Nos.
Equipments/Machines			
• AC series motor 240V 1/2 HP	- 1 No.		

PROCEDURE

TASK 1 : Connect, run and control speed at a AC single phase motors

- 1 Read the name-plate details and record in Table 1.
- 2 Determine the load current from the name plate

To drop 80 V at position 1 and to drop 40 V at position 2. Calculate the required series resistors R_1 and R_2 and also determine their wattage (see example given)

- 3 Make the connections as per diagram (Fig 1) and make necessary arrangements to load the motor through prony brake.

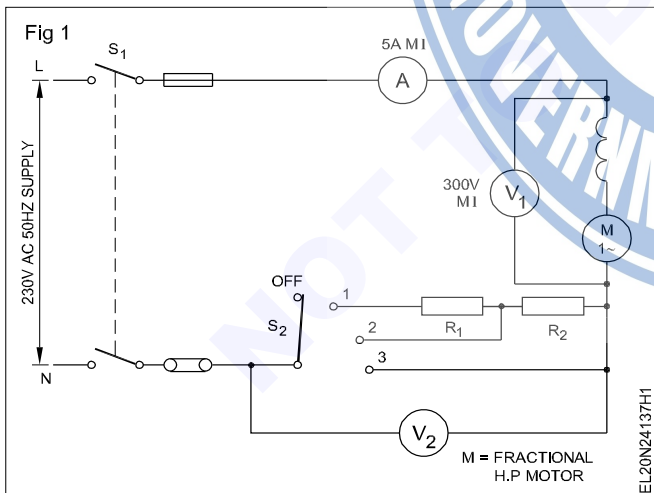

- 4 Close the switch S_1 .
- 5 Set the switch S_2 in position 1 and observe the starting of the motor.
- 6 Measure the current, voltages V_1 & V_2 and the speed. Record the values in Table 2.

- 7 Set the switch S_2 in position 2 and repeat the step 6.
- 8 Set the switch in position 3 and repeat the step 6.

Table 1

Manufacturer's name	
HP/KW	R.P.M.
Current	Voltage
Type	
SI.No.	Insulation

Table 2

Switch S_2 Position	Current	V_1	V_2	Speed

Compare starting and running winding currents of a capacitor run motor at various loads and measure the speed

Objectives: At the end of this exercise you shall be able to

- measure the current in each winding at a given load condition
- load the motor to a specified load.

Requirements		
Tools/Instruments		Materials
<ul style="list-style-type: none"> • MI Ammeter 0-5 A type • Tachometer 3000 rpm 	<ul style="list-style-type: none"> - 3 Nos. - 1 No. 	<ul style="list-style-type: none"> • Single pole knife switches 16A • I.C.D.P. Switch 16 A 250V • Connecting cable
Equipment/Machines		
<ul style="list-style-type: none"> • F.H.P. capacitor run motor 240V • Brake load arrangement 	<ul style="list-style-type: none"> - 1 No. 	

PROCEDURE

TASK 1 : Connect, run and measure starting and running current, speed of AC single phase capacitor run motor

- 1 Identify the terminals of starting winding and running winding.
- 2 Select the ammeter range suitable to the motor under test. Connect the circuit (Fig-1) with brake load arrangement.
- 3 Connect the single pole knife switches S_2 , S_3 and S_4 . (Fig 2)
- 4 Start the motor on no load and open the switch S_2 after the motor attains the rated speed.
- 5 Read and record ammeter readings in Table 1. Measure the speed and record in Table 1.
- 6 Adjust load until A_3 reads 1/2 full load current. Record the currents in each winding in Table 1.
- 7 Repeat the above step for full load.

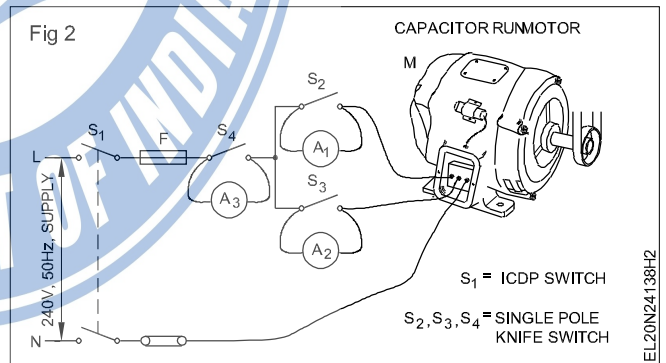
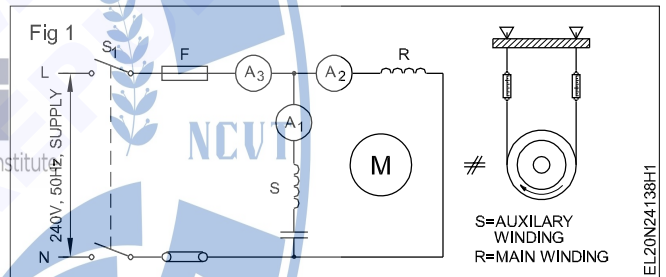

Table 1

Load	Speed	Ammeter reading		
		A_1	A_2	A_3
No load				
Half load				
Full load				

Carry out maintenance service and repair of AC single phase motors

Objectives: At the end of this exercise you shall be able to

- follow general maintenance and service procedure
- identify the general causes of failure and trouble shoot them.

Requirements	
<p>Tools/Instruments</p> <ul style="list-style-type: none"> • Electrician kit - 1 No. • Set of D.E. spanners 8 to 22 mm - 1 Set • Pulley puller 100 mm and 150 mm - 1 No. each • Nylon hammer 1/4 kg - 1 No. • Ohmmeter 0 - 1 kilo ohms - 1 No. • Industrial, thermometer, metric, 0 to 300° - 1 No. • Megger 0-500 V - 1 No. • Voltmeter M.I. type 0-300 V - 1 No. • Ammeter M.I. type 0-5 amps - 1 No. <p>Equipments/Machines</p> <ul style="list-style-type: none"> • Fraction horse power AC single phase (split phase) motor - 1 No. 	<p>Materials</p> <ul style="list-style-type: none"> • ICDP switch 16A 250V - 1 No. • Test lamp - 1 No. • Test prods 500V - 1 Set • PVC insulated copper cable 2.5 sq mm 250 V grade - 10 m • Fuse wire 5 amps capacity - as reqd. • PVC insulation tape 20 mm size - as reqd. • Bearing - Grease - 200 gms. • Kerosene oil - 1 litre. • Cotton waste - 100 gms • Shellac varnish - 1/4 litre • Sandpaper 'O' - as reqd.

PROCEDURE

TASK 1: Perform maintenance and service as per the following procedure

- 1 Read the name-plate details of the motor and record in Table 1.
- Table 1

Name-plate details of the motor

Make. _____	Frame _____	No. _____	Model _____
Type _____	HP _____	Volts _____	
Amperes _____	Phase _____	Cycles _____	
- 2 Switch 'OFF' the respective I.C.D.P. main switch.
 - 3 Remove the fuses and keep in safe custody.
- Remove the sub-circuit fuses which supplies power to the ICDP.**
- 4 Clean the main switch with a brush.
 - 5 Check the incoming and outgoing leads of the I.C.D.P. main switch for discolouring.
- Discolouring normally indicates loose terminal connection.**
- 6 Check the cable terminal connection screws and tighten them with the help of a screw driver.
- 7 Open the starter cover and clean the parts with a brush.
- 8 Check the leads and the terminal screws. Tighten the screws, if found loose.
- 9 Check the overload setting and if necessary, set it to the rated current of the motor.
- 10 Check the contact points of the starter for pitting.
- If the contact points are lightly pitted, use a sandpaper to clean them. Badly pitted or damaged contacts need to be replaced.**
- 11 Clean the external surface of the single phase motor using brush, a piece of the cloth and a blower.
 - 12 Open the terminal cover.
 - 13 Note the incoming, starting winding, running winding, capacitor and centrifugal switch connections and draw a diagram in your record. Indicate the colour of cables in the diagram.
- Normally some letter markings are found in the terminal plate. Some manufacturers give the schematic diagram on the back side of the cover. In case no diagram or marking were there wire clearly the colour of the cables**

connected to the terminal plate. Fig 1 is the schematic diagram of a particular single phase motor and Fig 2 shows the terminal connections with the simplified internal connections. These diagrams are given for your guidance. Draw the required diagrams to show the connections of the motor for which maintenance is required.

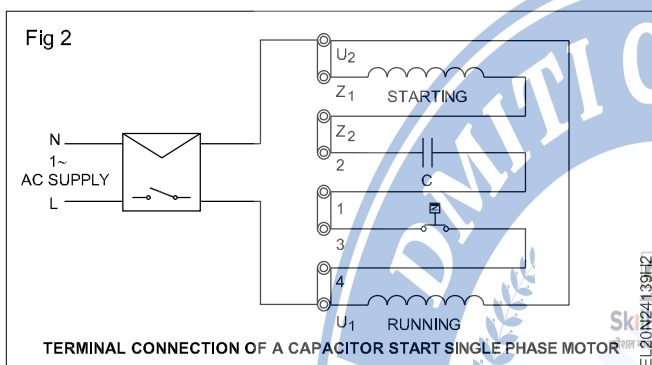
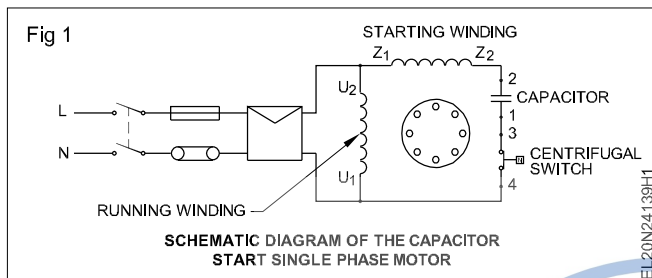

- 14 Open the shorting loops and incoming connections.
- 15 Check the continuity a) main winding b) starting winding c) centrifugal switch.
- 16 Measure the resistance value of the windings and contact resistance value of the centrifugal switch with an ohmmeter.
- 17 Check the capacitor and the centrifugal switch for its condition with an ohmmeter.

A capacitor when tested with a Megger or multimeter, the meter needle will show short indicating the capacitor is charged. When the capacitor terminals are shorted by a cable, a spark will be noticed indicating the capacitor is discharged and in good condition. However whether the capacity is charged or the capacitor able to hold the charge for a specified time cannot be checked by this test.

- 18 Check the insulation value of the windings with the help of a Megger.
- 19 Dismantle the motor following the procedural steps.

- 20 Clean the stator and rotor with a brush and blower.
- 21 Clean the bearings and grease cups with kerosene and check the bearing.
- 22 Identify the bearing which is found worn out replace it with a similar type.
- 23 Check the internal connections and lead insulations.

If necessary reinsulate the leads.

- 24 Check the rotor bars.

If any loose bar is found, it has to be brazed.

- 25 Check the rotor and stator surface for rubbing marks.

Rubbing marks indicate either worn out bearing or wrong alignment in assembly. Correct them.

- 26 Check the centrifugal switch for its tension and perfect contact between the points of contact.

If the switch is in a bad shape it should be replaced with a similar switch. Dressing of contact could be done with the help of sandpaper.

- 27 Identify the insulation resistance value measured earlier. If found to be less than 1 megohm, dry the winding in an oven or with incandescent lamps and varnish it.

- 28 Assemble the motor following procedural steps.

The test result should not vary too much. Rather it should show improvement. Discuss with your instructor regarding the test results.

- 29 Connect the shorting loops and incoming leads as per your diagram.
- 30 Replace the fuses of correct value in the fuse grip and replace the carrier in the holder of the I.C.D.P. mains.
- 31 Check the earth connections to the motor starter and switch correct them if necessary.
- 32 Start the motor and test run for about 30 minutes.
- 33 Check the frame temperature of the motor and satisfy yourself that the temperature is within the reasonable limits.
- 34 Check for any undue noise or vibrations.
- 35 Stop the motor and write your observations in the maintenance card.

If any undue noise or vibrations is found stop the motor and recheck the tightness of the end plate bolts and frame bolts.

TASK 2 : Trouble shooting procedure

- 1 Follow the troubleshooting charts No.1 to 5 to identify the symptom and rectify the fault.

Practice on single /double layer and concentric winding for AC motors, testing and assembling

Objectives: At the end of this exercise you shall be able to

- record the name plate details of the given single phase having single layer/double layer concentric type winding
- dismantle the motor
- collect the winding data
- draw the connection and developed diagrams
- strip the winding and clean the slots
- prepare the slot liners and insulate the slots
- prepare the stepped former and wind the concentric group of coils
- lay the coil groups in the stator slots
- connect the coil groups and phase leads
- shape the overhang
- test the winding
- varnish the motor
- test and run the newly wound motor.

Requirements			
Tools/Instruments		Equipment/Machines	
• Electrician tool kit	- 1 Set.	AC split phase motor FHP 250V	- 1 No.
• Scissors 250mm	- 1 No.		
• Nylon hammer 80 mm dia, 120mm long head	- 1 No.	Materials	
• Soldering iron 125W, 240V	- 1 No.	• Super-enamelled copper wire	- as reqd.
• Scale and weight 1 to 450 gms	- 1 Set.	• Millinex (or triplex paper) 10 Milli	- as reqd.
• Cold Chisel 100mm dia, 200mm long	- 1 No.	• Empire sleeve 1 mm, 2mm, 3mm, 4mm & 5mm	-1m.each
• Multimeter	- 1 No.	• Cotton tape 20mm roll of 25 m	-1 Roll
• Centre punch 100mm	- 1 No.	• Bamboo wedge	- as reqd.
• Steel rule 300mm	- 1 No.	• Resin Core solder 60:40	- as reqd.
• Wood rasp file, half round 200mm	- 1 No.	• Varnish (air dry)	- as reqd.
• Tray 200mm x 200mm x 50mm	- 1 No.	• Brush 25 mm	- 1 No.
• Megger 500 V	- 1 No.	• Fibre sheet	- as reqd.
• DE spanner 5 to 22 mm	- 1 Set	• PVC insulated copper wire 21/0.2 mm	- 3 m
• Outside Micro meter 0 - 25 mm	- 1 No.		

PROCEDURE

TASK 1: Rewind a single phase split phase motor (concentric coil winding)

Collection of data

- 1 Collect and record the machine data in Table 1.
- 2 Remove the pulley by using a pulley puller. Remove the fan cover and then remove the cooling fan blade assembly.

- 3 Mark both the end covers with distinguished markings with a centre punch, and correspondingly mark the body also.

Table 1

Name-plate details

Manufacturer's Name	Serial Number.....
Output.....KW/HP.	VoltageV CurrentAmps
FrequencyHz	Speed r.p.m. Cycle
Insulation	Frame No.Starting capacitor Mfd

Table 2

Winding data

1 Terminal marking with colour of the lead cables				
2 Connection end of the winding with respect to the terminal box				
3 No. of slots		No. of poles		Type of winding
4 Wedge material		size		Binding material
5 Overhang dimension		Non-connection end		Connection end
Outer dia.	 mm	 mm
Inner dia.	 mm	 mm
Length from core	 mm	 mm
6 Slot insulation materials		1		Size
		2		Size
7. Type of winding		Kind of wire end		No. of coils
1 Running			Coils/group
2 Starting	
8 Shaft side rotation		CW/ACW		
9 Coil size from outer coil		Starting winding		Running winding
		Length		Length
		Breadth		Breadth
10 Weight of running coils (Total)	 kg		
11 Weight of starting coils (Total)	 kg		
12 Lead wire : Type		Size		
		Front bearing No.		
		Rear bearing No.		
13 Core length				
14 Coil group connection diagram				
15 Any other information				
<i>Example:</i> Single phase capacitor motor				
No. of poles - 4				
No. of slots - 24				
No. of coils - 20 (12 for main and 8 for starting winding).				

4 Mark and remove the connection leads from the terminal box. Enter the details in Table 2.

5 Loosen the screw bolt/tie rod on both the end shield covers, and also remove the centrifugal switch connections.

- Remove the rotor from the stator.
- Inspect the rotor for any defect, and the bearing for its condition.

If any of the rotor bar is open correct the defect by brazing. If bearing is worn out replace it with a new one.

- Take the possible data before removing the coil and record it in Table 2.
- Mark the stator for indicating connection lead side with respect to the terminal box. Enter the details in Table 2.
- Apply a thinner in the connection lead side to loosen the varnish and locate the end connection. Draw the group connection diagram and also prepare the developed diagram in a separate sheet of paper and attach with these sheets.

To avoid imaginary terms while writing the procedure, an example for a single phase capacitor motor having concentric coil winding is given below.

Certain procedural steps are specifically written for the motor given in this example. However, you have to follow the data taken strictly from the given motor, to get the required performance.

Information from collected data

- Coil pitches - Main winding 5,3,1
Starting winding 5,3
- Coil throw - Main winding 1-6,2-5,3-4
Starting winding 1-6, 2-5

This is the whole coil connection as the end of the 1st coil is connected to the end of the 2nd coil and the starting of the 2nd coil is connected to the starting of 3rd coil etc.

For your guidance, the group connection diagram is given in Fig 1 and the developed diagram is given in Fig 2.

- Measure the overhang at both sides of the winding. Record it in Table 2 and prepare the template.
- Collect the possible data like, number of slots, coil pitch etc. and record in Table 2.

TASK 2 : Test the winding

- Check the winding for short circuit, open circuit and insulation resistance by a multimeter and Megger respectively.
- Check the condition of the capacitor and centrifugal switch. If there is any fault replace them by new ones.
- Connect the lead connections, capacitor and centrifugal switch according to the connection diagram and terminate them in the terminal box.
- Assemble the motor and then run the motor for 15 minutes.

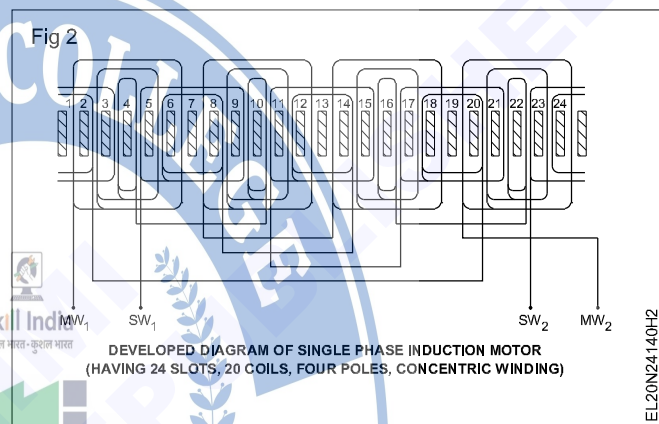
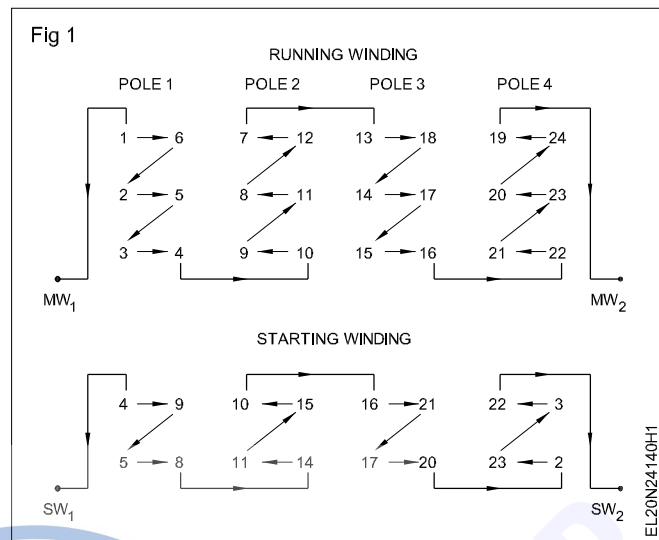

- Cut the coils except one set of coils each in the starting and main winding with the help of a cold chisel at the non-connection end (i.e. normally load side).

- Strip the old winding from the stator slot. If it is hard use a blowlamp to heat the winding and pull out the coils.
- Remove the left out coils in their original shape.

Use a thinner to loosen the coils. Once a thinner is used never use the blowlamp as the coils will catch fire.

- Measure the size of the wire, size of the coil and collect other details as required and record them in Table 2.

Connect, start, run and reverse the direction of rotation of universal motor

Objectives: At the end of this exercise you shall be able to

- connect a universal motor to the supply through a D.O.L. starter and start the motor
- reverse the direction of rotation of a universal motor.

Requirements	
Tools/Instruments <ul style="list-style-type: none"> • Insulated cutting pliers 150 mm - 1 No. • Screwdriver 150 mm - 1 No. • D.E. spanner set 5mm to 20 mm - 1 Set • Megger 500 V - 1 No. • Test lamp 100W/240V - 1 No. • Ohmmeter/multimeter - 1 No. • Tachometer 1500-15000 r.p.m. - 1 No. 	Equipments/Machines <ul style="list-style-type: none"> • Universal motor 250V, 50 Hz, 0.5 HP - 1 No. Materials <ul style="list-style-type: none"> • 2.5 mm multi-strand PVC copper cable - 10 mts. • Bare copper wire 14 SWG - 05 mts. • 250 V 16A, I.C.D.P. switch - 1 No. • D.O.L. starter 250V suitable for 0.5 HP single phase motor - 1 No.

PROCEDURE

- 1 Arrange and adjust a suitable load for the given universal motor.
- 4 Connect the motor as per circuit diagram (Fig 1) with proper frame earth connections.

A universal motor has high starting torque. Without load, the motor reaches a dangerously high speed resulting in damage. Normally do not arrange loading through the flat belts which may slip during running. Arrange direct drives or 'V' belt drives as load.

Check for the correct load arrangement before starting the motor.

- 2 Select the proper rating of I.C.D.P. switch, cables, fuse and starter, according to the rating of the given universal motor.
- 3 Open the starter cover, trace out the connection and set the overload relay to the motor current rating.
- 5 Switch on the I.C.D.P. and push the 'ON' button of the starter.
- 6 Observe the D.O.R. and record it below.
The D.O.R. is _____
- 7 Measure the speed with a tachometer and record it below. The speed is _____ r.p.m.

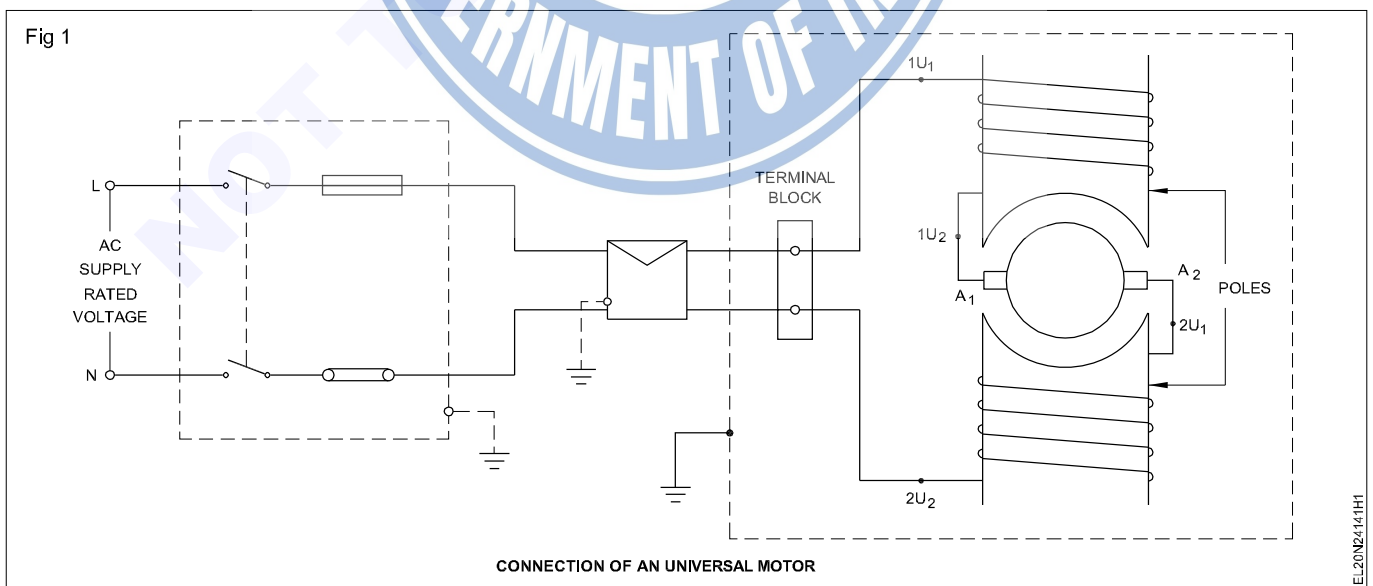
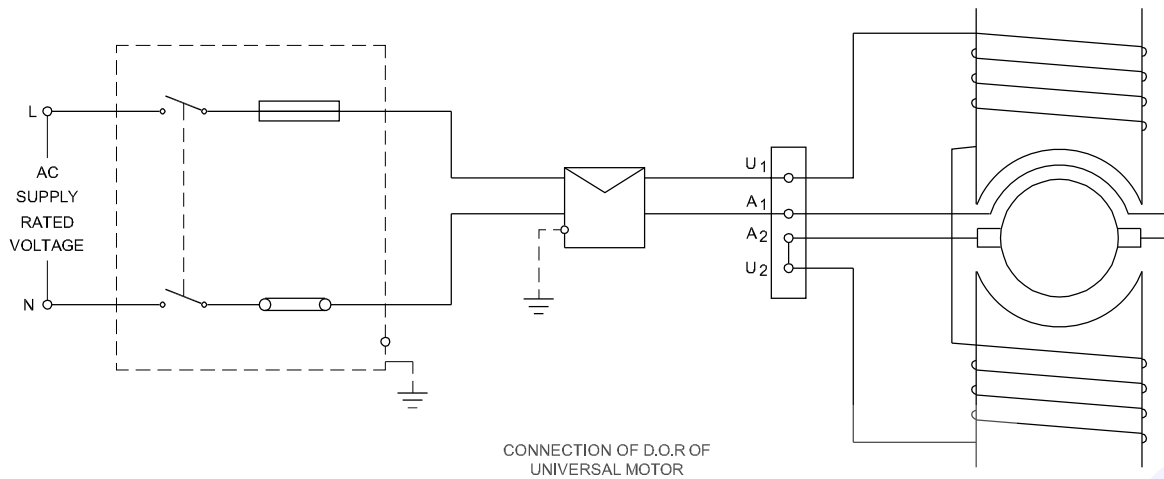

Fig 2



EL20N24141H2

The speed of a universal motor depends upon the load. While setting the range of the tachometer, first set at a high range and then step down the range to a suitable measurable value.

In case reversing the direction of rotation of the motor is necessary, change either field or armature terminals. While changing the armature terminals of compensated universal motor, change the compensating winding terminals also.

- 8 Stop the motor by the stop-bottom of the starter. Switch off the I.C.D.P. and remove the fuse.

- 9 Discuss with your instructor the possibility of alternate connections to the one. (Fig 2)

Change the direction of rotation

- 10 Change either the field or the armature terminals.

Generally the D.O.R of the universal motor is designed in one direction by the manufacturer. Changing the direction of rotation in such cases will result in high sparking, increased heating and failure of the machine.

- 11 Follow the procedural steps 5 to 8 and record the direction of rotation and speed in the space given below:

The D.O.R. is _____
The speed is _____

Carry out maintenance and servicing of universal motor

- Objectives:** At the end of this exercise you shall be able to
- read and interpret the name-plate details of the motor
 - inspect and ascertain the conditions of the motor
 - dismantle the universal motor
 - test and rectify the faults
 - assemble and test the universal motor
 - troubleshoot the universal motor.

Requirements	
<p>Tools/Instruments</p> <ul style="list-style-type: none"> • Electrician tool kit - 1 Set • Philips screwdriver 200mm - 1 No. • Cold chisel 200 mm - 1 No. • Spanner set double ended set of 8 Nos. 6mm to 25 mm - 1 Set • Mallet (wooden) 7.5 cm dia - 1 No. • Bearing puller - 1 No. • Megger 500 V - 1 No. • Ohmmeter 0 to 1 kilo ohm - 1 No. • External and internal growler - 1 Set <p>Equipments/Machines</p> <ul style="list-style-type: none"> • Universal motor as available - 1 No. 	<p>Materials</p> <ul style="list-style-type: none"> • Test lamp 60W 250V - 1 No. • Cotton waste - as reqd. • Bearing grease quality and quantity - as reqd. • Sandpaper smooth sheet of 300 mm square - as reqd. • Kerosene oil - 1/2 litre. • Empire cloth 1 mm - as reqd. • Carbon tetrachloride - as reqd. • Empire sleeves 3 mm to 6 mm - as reqd. • Carbon brushes of suitable grade and size - 2 Nos. • Lead and tin solder (Resin cored) -20 grams.

PROCEDURE

TASK 1 : General maintenance and servicing procedure

1 Note the name-plate details of the motor and enter in complaint card shown in Table 1.

Table 1

Complaint card

Customer _____	Date _____	Job No. _____	Make _____
Frame No. _____	Model _____	Type _____	HP _____
Volts _____ Ampere _____ Phase _____ Cycles _____			
Serial No. _____			
Suggestion/Complaint : _____			
Signature of Section in-charge _____			

Table 2

Results of visual inspection

Sl.No.	Description of visual inspection	Result of visual inspection

- 2 Inspect the motor visually and record the defects in Table 2.
- 3 Read the complaint card and ascertain the area of trouble.
- 4 Conduct, continuity, open circuit and insulation resistance tests and enter the values in Table 3.

- 5 Mark the exact position of the end plates with yoke.
- 6 Dismantle the machine.
- 7 Clean the internal parts of the motor.
- 8 Check the following.
 - a) Test the shorting between commutator segments. (Fig 1)
 - b) Clean the commutator with carbon tetra chloride.
 - c) Check the mica insulation; if found raised beyond the commutator surface undercut the mica.(Fig 2)

Table 3
Test results

Sl. No.	Description	Continuity Test		Insulation resistance		Resistance Test		Remarks
		Before Dismantling	After Assembling	Before Dismantling	After Assembling	Before Dismantling	After Assembling	
1	Field winding							
2	Armature winding							

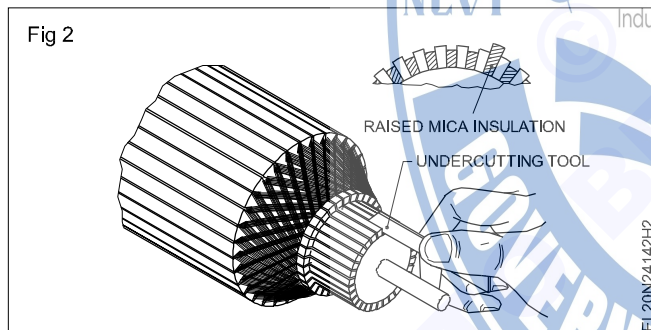
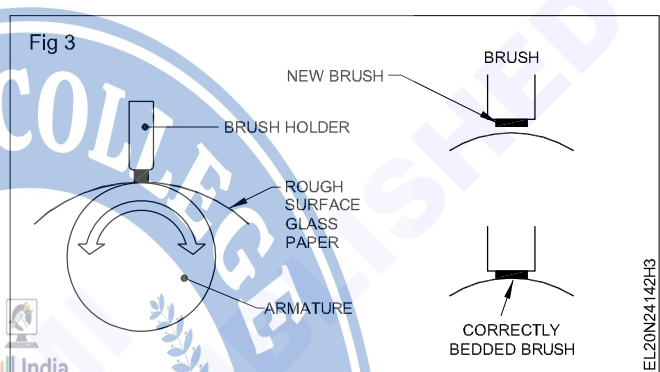
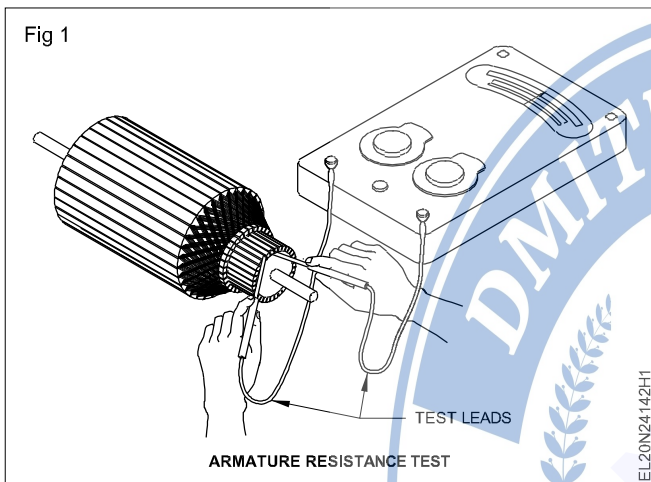

- d) Check the commutator surface for pitting. If necessary use sandpaper to remove the pitting.
- e) Check for overheated spot at raiser and resolder the wires if necessary.
- f) Check the length of brushes. If found short, replace them with the same grade of correct size brushes.
- g) Check the brushes for proper bedding. If necessary bed the brushes. Refer Fig 3.

- h) Check the bearing for ply or damage.
- i) Replace the damaged or defective bearing with the new one having same specification.

If the old bearing is good, then clean the bearing and repack the bearing with grease approved by the manufacturer.

- j) Assemble the motor.
- k) Check whether the rotor shaft is free to rotate.

In case, the rotor shaft is hard to move or too tight, loosen the end covers and retighten them in a sequence till the rotor is free to rotate.

- l) Check the brush tensions and if necessary adjust it.
- m) Perform the earlier tests and enter the results in Table 3.

The present test results should be better than earlier ones. If not try to investigate the problem area and rectify.

- n) Check the earth connections of the motor, starter and switch and correct them if necessary.
- o) Start the motor with partial load and check its performance.
- p) Check for undue raise in motor temperature, noise and vibrations.
- q) Verify the defect following the trouble shooting chart if necessary.

Insert the new brush and shape the end to the curve of the commutator using glass paper wrapped around the commutator and light pressure on the brush.