

**Identify parts and terminals of three phase AC motors**

**Objectives:** At the end of this exercise you shall be able to

- read and interpret the name plate details of the given 3 phase squirrel cage induction motor and slip ring induction motor
- identify their parts and write their names
- test the 3 phase squirrel cage induction motor for continuity test
- identify the terminals of 3-phase squirrel cage and slip ring induction motors.

Requirements	
<p><b>Tools/Instruments</b></p> <ul style="list-style-type: none"> <li>• Insulated combination plier 200mm - 1 No.</li> <li>• Insulated screw driver 200mm with 4mm blade - 1 No.</li> <li>• DE spanner set 5 mm to 20mm - 1 Set</li> <li>• MI volt meter 0-300 V - 1 No.</li> <li>• MI volt meter 0-500 V - 1 No.</li> <li>• Test lamp 240V, 60 Watts - 2 Nos.</li> </ul>	<p><b>Equipments/Machinery</b></p> <ul style="list-style-type: none"> <li>• AC 3 phase squirrel cage induction motor - 5HP, 3-Phase, 415V, 50Hz - 1 No.</li> <li>• AC 3 phase slip ring induction motor - 5HP, 3-Phase, 415V, 50Hz - 1 No.</li> </ul> <p><b>Materials</b></p> <ul style="list-style-type: none"> <li>• PVC Insulated copper cable 1.5 sq mm - 4 m</li> <li>• Pendant lamp-holder 240V 6A - 2 No.</li> </ul>

**PROCEDURE**

**TASK 1: Identify the parts of 3 phase squirrel cage induction motor**

- 1 Read and interpret the name plate details of the 3 phase squirrel cage induction motor.
- 2 Identify the parts of the AC squirrel cage induction motor from the real objects or from the exploded view chart (Fig 1)
- 3 Label the each identified parts with number tags.
- 4 Write the name of the parts of each labelled number tag in Table 1.

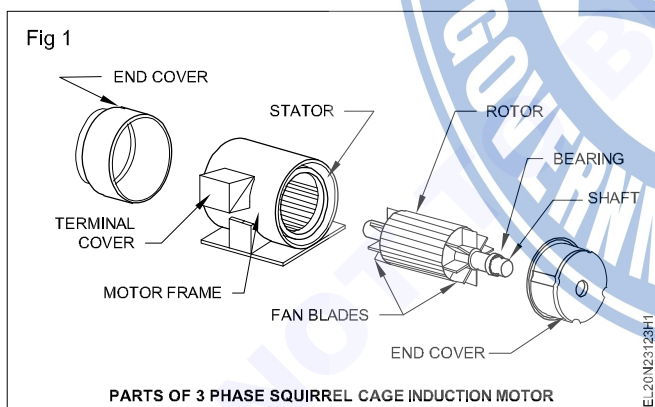

Table 1

S. No.	Label Number	Name of the parts of squirrel cage induction motor
1		
2		
3		
4		
5		
6		
7		

- 5 Get it checked with your instructor.

**TASK 2: Identify the parts of AC 3 Phase slip ring induction motor**

- 1 Read and interpret the name plate details of the 3 Phase slip ring induction motor.
- 2 Identify the parts of the AC 3 Phase slip ring induction motor from the real objects (or) from the exploded view chart (Fig 1).
- 3 Label the each identified parts with number tags
- 4 Write the name of the parts of each labelled number tags in Table 1.

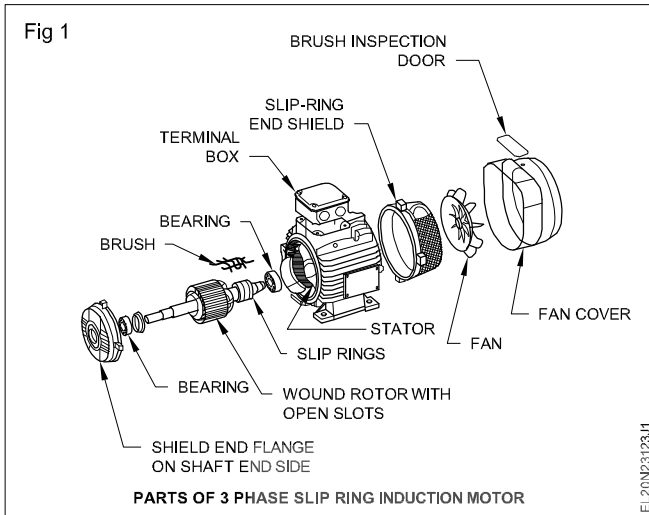

Table 1

S. No.	Label No.	Name of the part
1		
2		
3		
4		
5		
6		
7		
8		
9		
10		
11		
12		

5 Get it checked with your instructor.

**TASK 3: Identify the terminal of a 3 phase squirrel cage induction motor**

**METHOD 1:** Identifying the terminals of a 3-phase induction motor with the help of two lamps in series

and V as shown in Fig 3a and give 250 AC voltage across  $U_1$  and  $U_2$ .

**Lamps should be equally rated both in voltage and wattage. (Fig 1)**

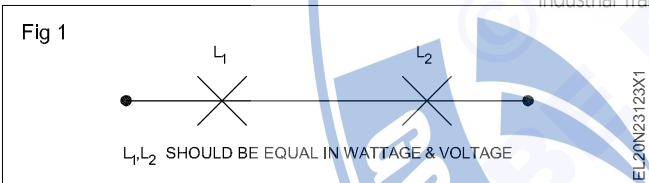

2 Test for continuity with the help of a test lamp and find the 3 pairs out of six terminals of the induction motor. (Fig 2)

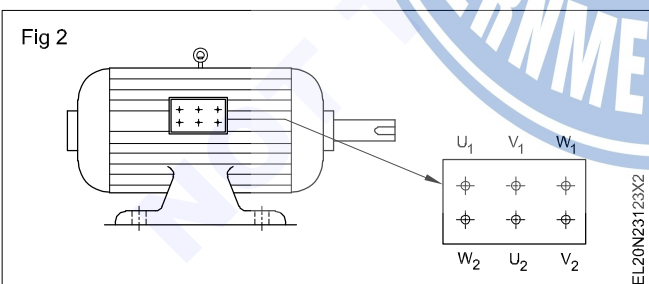

3 Identify the 3 pairs of terminals, name them as 'U' coil, 'V' coil and 'W' coil.

4 Tag  $U_1$  and  $U_2$  for 'U' coil only. For other coils tag  $V_1$  and  $V_2$  for 'V' coil and  $W_1$  and  $W_2$  for 'W' coil as shown in Fig 1.

5 Connect the terminals  $U_1$  to V and then connect the series combination of the lamps to the winding ends  $U_2$

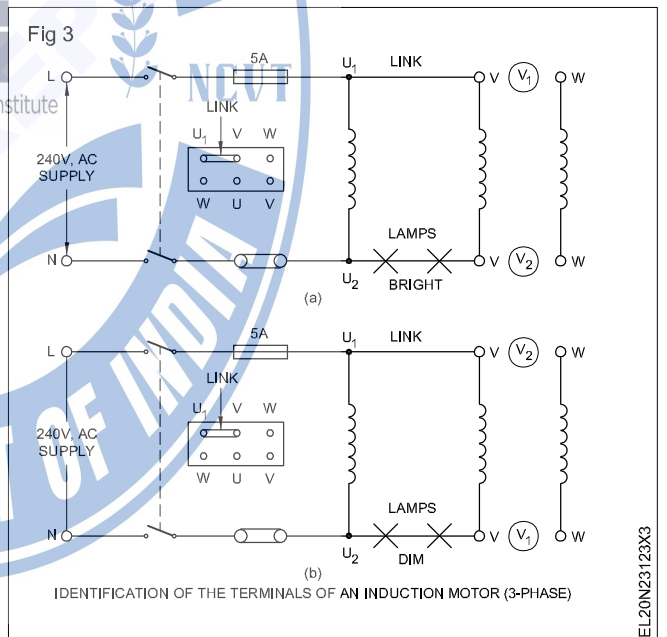

**If the lamps glow bright as shown in Fig 3a then the linked ends are similar ends. For example, the linked ends are  $U_1$  and  $V_1$ .**

**If the lamps glows dim as shown in Fig 3b, then the linked ends are dissimilar ends. For example, the linked ends are  $U_1$  and  $V_2$ .**

6 Check to the test result in step 6 or 7, mark the name of V coil terminals as  $V_1$  and  $V_2$ .

**When the current flows through the coils they produce magnetic fields. If similar ends are connected, the magnetic fields help each other and produce high voltage across the lamp terminals making them to glow bright. In the case of dissimilar connections the voltage at lamp terminals will be low and the lamps will give dim light.**

- 7 Test in the same way for the remaining terminals of coil 'W' and mark them as  $W_1W_2$ .

**METHOD 2:** Identifying the terminals of a 3-phase induction motor with the help of a voltmeter

- 1 Repeat the steps 1 to 4 of Method 1.
- 2 Connect the terminals  $U_1$  and V with a link, connect a voltmeter  $V_L$  of 500V range between  $U_2$  and V and a voltmeter  $V_P$  of 300V range between  $U_1$  and  $U_2$  as shown in Fig 4.

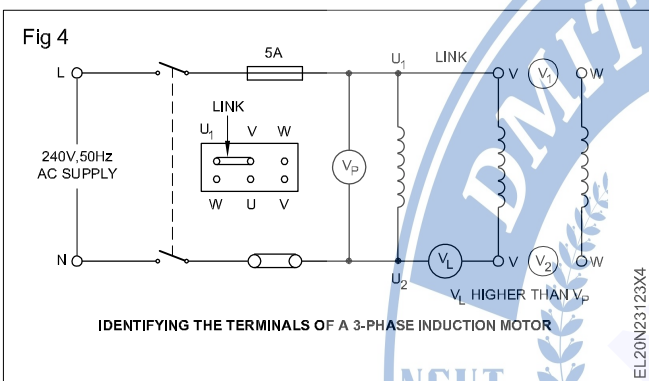

- 3 Switch 'on' the supply, if the voltmeter  $V_L$  reads more than  $V_P$ , then the linked terminals are similar as shown in Fig 2 (i.e  $U_1V_1$ ).
- 4 Check the voltmeter  $V_L$  reads less than  $V_P$ , then the linked terminals are dissimilar (i.e  $U_1V_2$ ). Mark them as  $U_1V_2$ .
- 5 Test in the same way the remaining terminals of coil 'W' and mark them as  $W_1$  and  $W_2$ .

**METHOD 3:** Identifying the terminals of a 3-phase induction motor with the help of single lamp method

- 1 Connect the terminals as shown in Fig 5a. Connect it to a 240V AC supply and switch on the supply.
- 2 Check the lamp glows, the linked terminals are dissimilar. i.e  $U_2V_1$ . Mark them as  $U_2V_1$ .

**If the lamp does not glow, the linked terminals are similar (i.e  $U_2V_2$ ). (Fig 5b) Mark them as  $U_2$  and  $V_2$ .**

**When current flows through the coils they produce magnetic fields. If dissimilar ends are shorted (linked) they assist each other and voltage induces in the third coil and the lamp glows. If similar ends are linked, the magnetic fields oppose each other and no voltage will be induced in the third coil. Hence the lamp does not glow.**

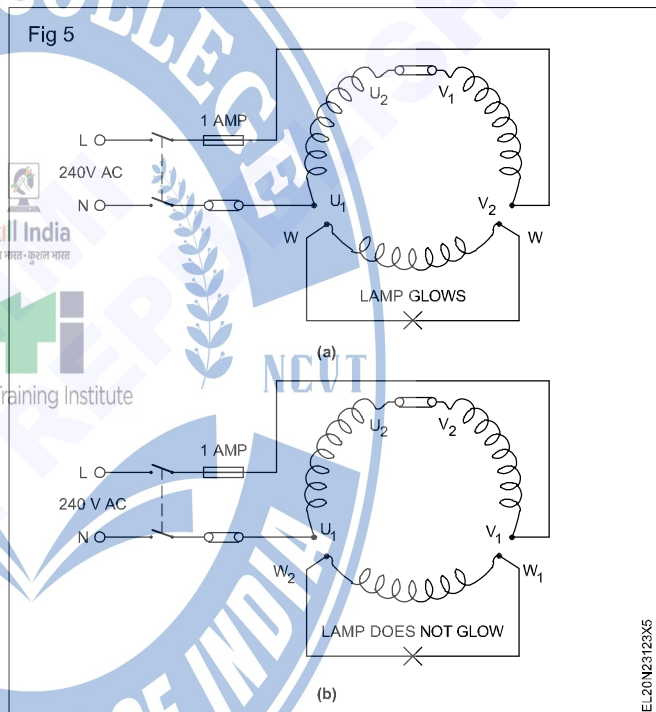

#### TASK 4: Identify the terminal of a slip ring induction motor

- 1 Remove the terminal box cover and sketch the layout of the terminals. (Fig 1)

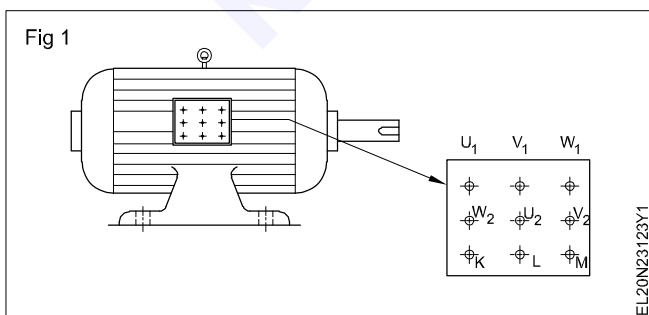

- 2 Test for continuity with the help of a test lamp and find out rotor's three terminals out of nine terminals of the slip ring induction motor
- 3 Connect probe - 1 to any one of the 3 slip rings or brush
- 4 Touch probe - 2 to terminals of motor one by one.
- 5 Check the test lamp burns then that terminals are rotor terminal.
- 6 Put name them as KLM and remaining six terminals are stator terminals.

**The above test will not be valid until and unless the following conditions are observed.**

**Condition 1:** Check and ensure that the earth continuity conductor (E.C.C) connected to them main earth electrode is in perfect continuity, having a resistance of less than 1 Ohm.

**Condition 2:** The resistance of the earth electrode should be less than 5 ohms unless otherwise stated.

8 Draw connection diagram for the 3 phase slip ring induction motor (Fig 2).

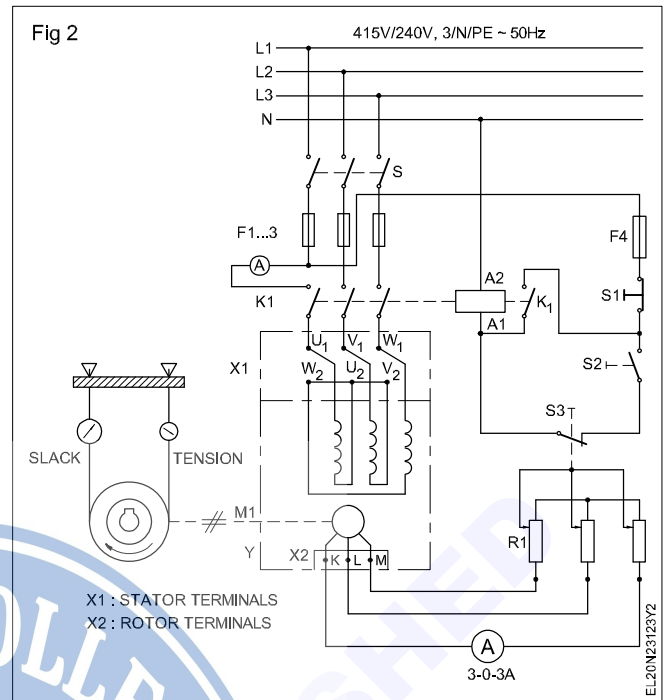

**Make an internal connection of automatic star-delta starter with three contactors**

- Objectives :** At the end of this exercise you shall be able to
- identify the major parts of automatic star delta starter
  - read and trace the internal circuit diagram of the starter.

Requirements	
<b>Tools/Instruments</b>	<b>Materials</b>
<ul style="list-style-type: none"> <li>• Connector/Screw driver 100 mm - 1 No.</li> <li>• Spanner Set (6mm -25mm ) - 1 Set</li> <li>• Multimeter - 1 No.</li> </ul>	<ul style="list-style-type: none"> <li>• PVC insulated copper wire - as reqd.</li> <li>• 2.5 sq mm, 250V grade</li> <li>• Cleaning brush 3 cm dia - 1 No.</li> <li>• Carbon tetra chloride (CTC) - 5 0 ml.</li> <li>• Grease type and quantity - as reqd.</li> <li>• Kerosene - 1 litre</li> <li>• Lubrication oil type and quantity - as reqd.</li> <li>• Cotton cloth - as reqd.</li> <li>• Sand paper/sand cloth-grade and quantity - as reqd.</li> <li>• Solder 60/40 - as reqd.</li> <li>• Soldering flux - as reqd.</li> </ul>
<b>Equipment/Machines</b>	
<ul style="list-style-type: none"> <li>• Semi automatic star-delta starter 10A 415v,50Hz - 1 No.</li> <li>• Automatic star-delta starter 10 A 415v to 50 Hz - 1 No.</li> <li>• 3 Phase 415V 3 Hp/5 Hp squirrel cage induction motor with 6 terminals - 1 No.</li> </ul>	

**PROCEDURE**

**TASK 1 : Make internal connections of automatic star-delta starter with three contactors**

- 1 Collect the automatic star-delta starter without internal connections from the instructor.
- 2 Name the external parts indicated by the numbers in Fig 1.
- 3 Name the internal parts of an automatic star-delta starter indicated in Fig 2.
- 4 Read the power and control diagrams (schematic) in Fig 3.
- 5 Draw and complete the connections for power circuit only conforming to Fig 3 (i.e connection between supply, contactors, overload relay and motor terminals).
- 6 Draw the connections of the control circuit on the diagram for automatic star-delta operation. Observe the sequence indicated in the schematic diagram. (Fig 3)
- 7 Open the cover of the automatic starter and read the circuit diagram given with it.
- 8 Check the working of the contactors with a multimeter by manually actuating the contactor.
- 9 Mount the contactors, overload relay, stop and start push-buttons on the T.W board.
- 10 Wire up the control circuit with the help of connecting wires.

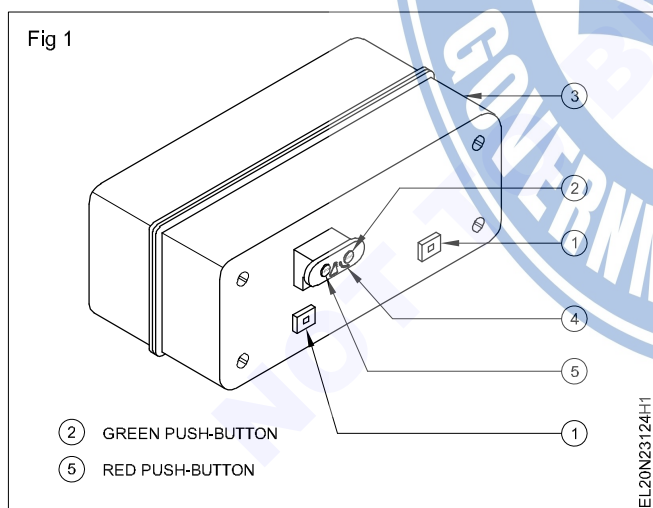

- 11 When separate contactors and other parts for an automatic star-delta starter are not available, remove the contactors, overload relay and the timer with the starter and mount on a plain vertical board for easy interconnections.
- 12 Label the contactors, star, delta and main.
- 13 Give supply control circuit and check for the logical sequence of closing and opening contactors.

**Use single strand conductors only. Make proper termination.**

**The space available within the starter is very limited and making connection consumes more time, and is a special skill of panel wiring.**

Fig 2

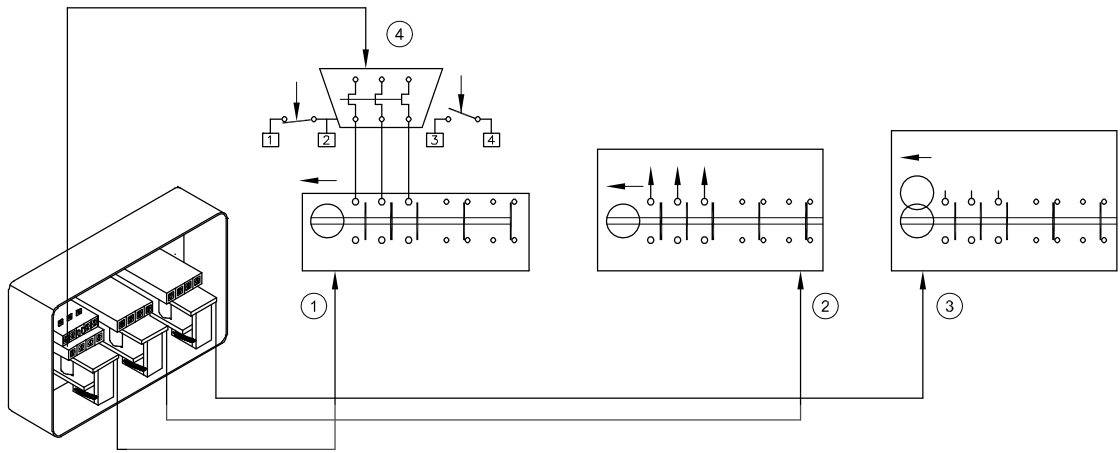

EL20N23124H2

Fig 3

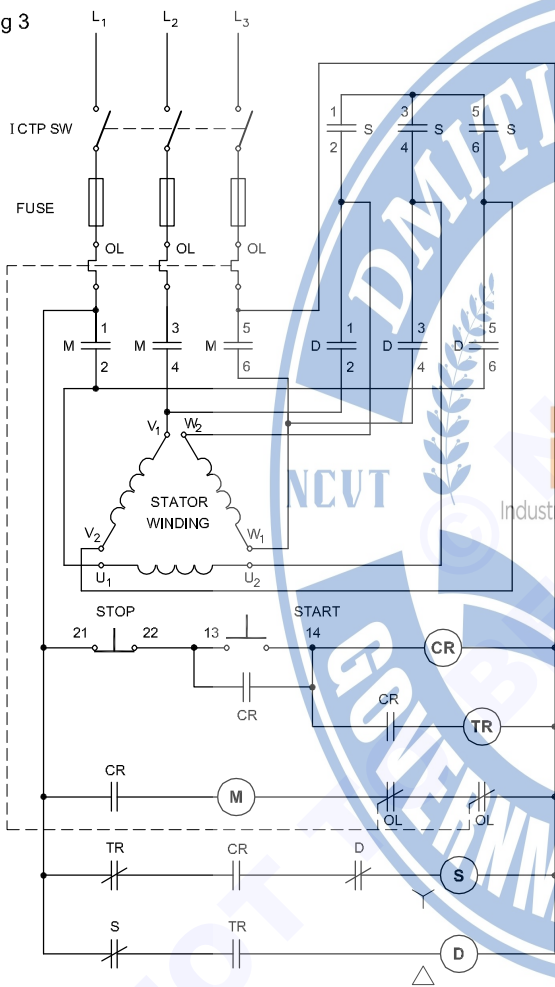

Industrial Training Institute

EL20N23124H3

14 Call the instructor and get his approval to make the power circuit connections of the star-delta starter.

15 Wire up the power circuit on the star-delta starter according to the circuit diagram.

16 Read the name-plate details of the motor. Check the suitability of the fuse for the motor to be connected.

17 Connect the motor to the 3-phase supply through the starter.

18 Start the motor and observe the starting. Check what speed the starter switches over from the star to delta.

19 Answer the statement.

At what speed the switching over from star-y connection to Delta connection happens?

- a) above 70% of normal speed
- b) below 70% of normal speed

**The turning of the set screw increases or decreases the gap between normal strip of timer relay causing more or less time to actuate contact mechanism.**

20 Press the start-button again and check. There should not be any effect in the motor running.

21 Disconnect the motor from the supply after opening the ICTP isolating switch.

## Electrician - AC Three Phase Motor

## Connect, start and run three phase induction motor by using DOL, star-delta and auto transformer starters

**Objectives:** At the end of this exercise you shall be able to

- identify and collect the parts of a DOL starter
- assemble the DOL starter and make control circuit connection
- connect ICTP switch and DOL starter with 3 phase motor
- set the overload relay and replace correct capacity fuse
- start and stop the 3 phase motor through DOL starter
- Identify the parts of a manual star-delta starter and trace the connection
- connect the manual star delta starter with 3 phase squirrel cage motor
- adjust the over load relay according to the motor current rating
- start and stop the motor through the star delta starter
- reverse the direction of rotation of the motor
- connect a 3 phase induction motor with an auto transformer and contactor as starter
- start and run a 3 phase induction motor using auto transformer and contactor.

Requirements	
<b>Tools/Instruments</b>	
• Combination pliers 200 mm	-1 No.
• Screw driver 200 mm, 300 mm	- 2 Nos.
• Connector screw driver 100 mm	- 1 No.
• Wire stripper 150 mm	-1 No.
• MI Ammeter 20A, 10A	-2 Nos.
• MI Volt meter 0-500V	-1 No.
• Tachometer 0-3000rpm	-1 No.
<b>Equipment/Machines</b>	
• Contactors 415V AC with 240V operating coil having 16A - 3 power circuit contacts 2A - 4 auxiliary change over contacts	- 4 Nos.
• Delay time relay, 24V AC operating coil with 1 or 2 normally open contacts	- 3 No.
• 3-phase Squirrel cage motor 415V, 50 Hz, 3HP, 5 HP	- 2 Nos.
• DOL starter 10 Amp 415V	- 1 No.
• Manual star-delta starter 16A, 415V	- 1 No.
• TPIC switch 16A 415V	- 1 No.
<b>Materials</b>	
• PVC Insulated single strand copper cable 16 SWG, 18 SWG	- 0.5 m
• Machine screw 2BA.30mm long with two washers and one nut	- as reqd.
• Power cable single strand 2.5 mm <sup>2</sup>	- as reqd.
• GI wire 145WG	- 8 m

## PROCEDURE

## TASK 1: Identify the parts of a DOL starter connect, start and run the 3 phase induction motor

- 1 Collect the contactor unit, overload relay unit, start/stop push-button unit, the necessary fixing screws, hookup cables, I.C.T.P switch and D.O.L starter base and cover.
- 2 Record the name plate details of the contactor and overload relay in your record respectively.
- 3 Identify the connecting terminals for interconnecting no-volt coil, main supply to control circuit, normally open auxiliary contacts.

## Refer and recapitulate the connection diagram

- 4 Draw the complete circuit diagram for the given D.O.L starter with overload relay, no-volt coil, 'ON' and 'OFF' push-buttons.

For your guidance following diagrams are given for a starter of a particular make.

Fig 1 shows Overload relay package with push-button strips in the foreground which will get actuated when the push-buttons are pushed.

Fig 2 shows Contactor with no-volt coil.

5 Get the approval instructor for diagram.

6 Mount the accessories in the starter base box with the help of mounting screws.

Do not tighten the screws more than necessary as too much tightening of screws will break the PVC casing of the contactor and OL relay.

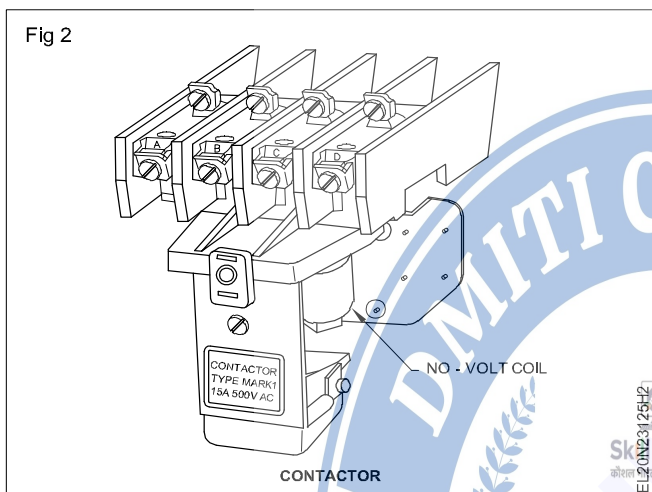
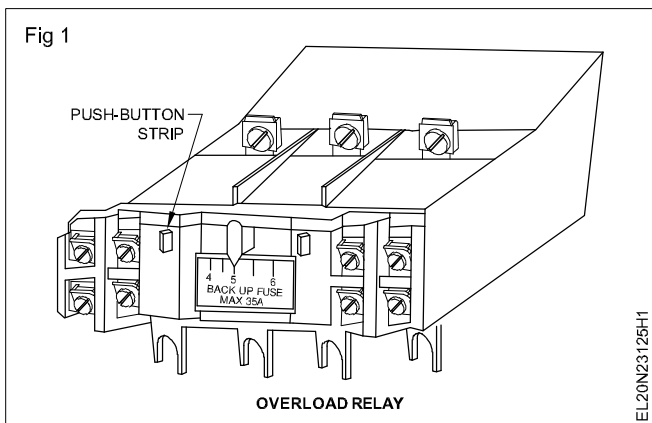

- 14 Connect the protective earthing continuity conductors (two separate PE connections) to the motor and starter case, ICTP switch, and connect securely the PE continuity conductors to the main earth. (Fig 1)

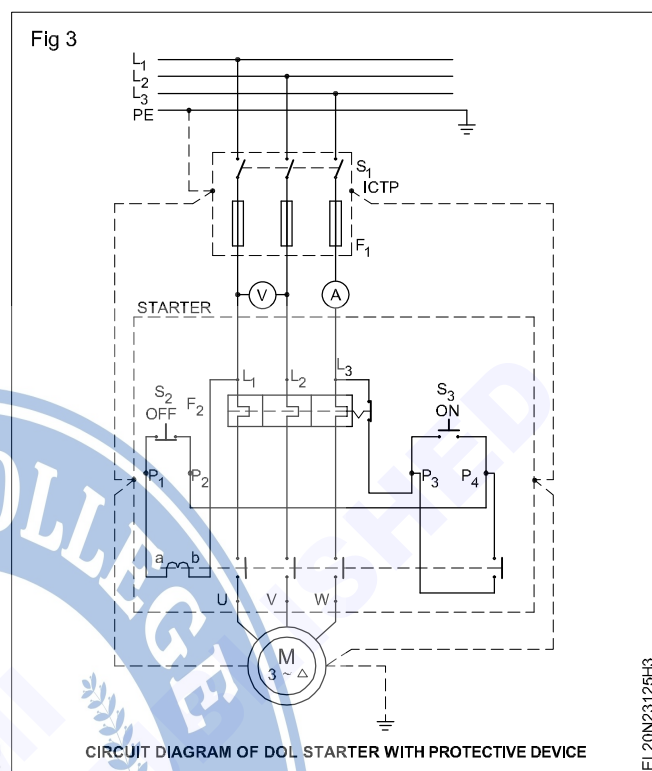

- 7 Connect the hook-up cables according to the approved diagram.
- 8 Check up once again the complete connection of the D.O.L starter internal wiring.
- 9 Get the wiring approved by your instructor.
- 10 Identify the holes in the starter base box for mounting the starter on the wall/frame.
- 11 Mount the starter vertically on the wall/frame.
- 12 Connect the main supply to the starter incoming terminals through the I.C.T.P switch. (Fig 3)
- 13 Connect the starter outgoing terminals to the 3-phase squirrel cage induction motor along with the ammeter and voltmeter. (Fig 1)
- 14 Connect the protective earthing continuity conductors (two separate PE connections) to the motor and starter case, ICTP switch, and connect securely the PE continuity conductors to the main earth. (Fig 1)
- 15 Investigate the full load current of the motor and set the overload relay of the starter to that rating.
- 16 Provide a backup fuse as recommended by the manufacturer of the starter considering the horsepower rating of the motor.
- 17 Get the main connections, earth connections, overload setting and the backup fuse rating approved by your instructor.
- 18 Switch on the ICTP.
- 19 Start the motor by the start ( $S_3$ ) button of the starter.
- 20 Read the ammeter for the starting current at the time of starting.
- 21 Read the voltmeter and ammeter values when the motor shows normal running.
- 22 Measure the actual speed of the rotor with the help of a tachometer.
- 23 Switch OFF the motor using stop ( $S_2$ ) button of the starter.
- 24 Show the readings to your instructor.

**The position of the starter should be such that the no-volt coil mechanism works properly, taking advantage of the gravitational pull while disengaging.**

**Use a plumb bob or spirit level to check the verticality.**

**Before connecting the 3-phase squirrel cage motor, test it for continuity and insulation.**

**TASK 2 : Start, run and reverse a AC 3 phase squirrel cage induction motor by manual star/delta starter**

- 1 Read and interpret the name-plate details of the starter.
- 2 Identify the parts of the given star-delta starter, trace the connections and verify its operation. Draw the traced out circuit and get it approved by the instructor. (Fig 2)

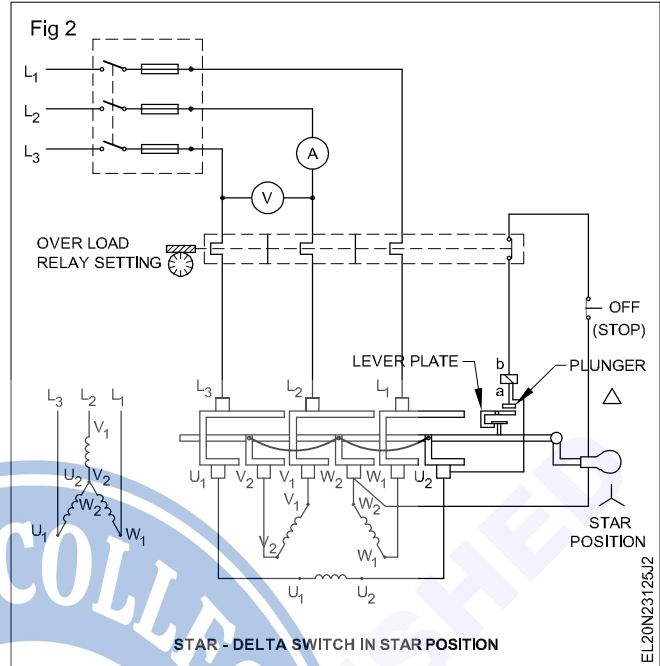
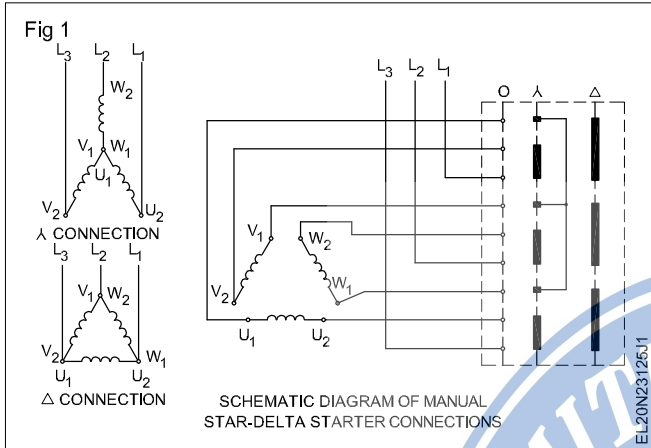

- 3 Make the connections of the motor, starter and the ICTP switch as per the approved diagram.
- 4 Connect three cables from supply  $L_1, L_2$  &  $L_3$  to the main switch. (Fig 3)
- 5 Insert the ammeter in series with one of the line cables from the main switch and a voltmeter across two line cables. (Fig 3)

- 6 Wire the proper fuse element according to the given motor rating in the fuse-carrier and insert the carriers in the main switch.
- 7 Set the overload relay according to the full load current rating of the motor.
- 8 Provide double earth to the metal body of the main switch, starter and the motor frame.

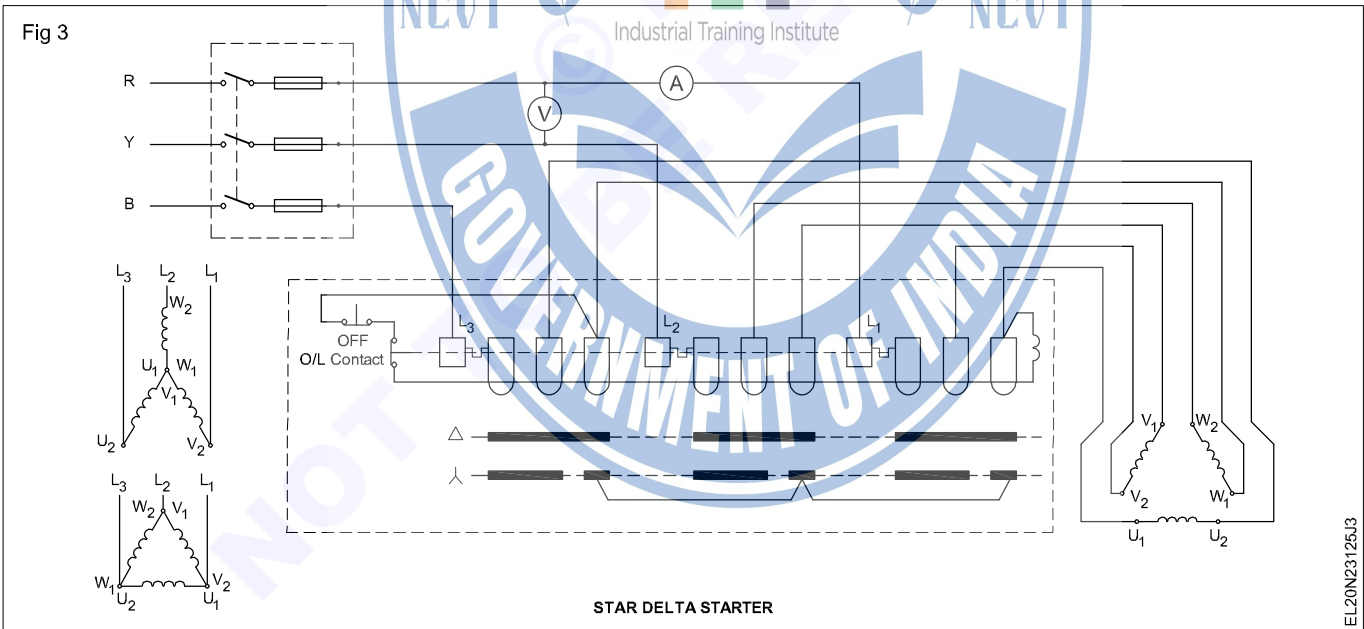

**ASSUMPTION : Check the connections for correctness and tightness. Get it approved by the instructor.**

- 9 Switch 'on' the main, observe the voltmeter reading and move the handle to the star position positively and at the same time observe the starting current and enter it in Table 1.

- 10 Allow the motor to start, race initially and let the sound of the rotating shaft come to a steady state; then move the handle to the delta position positively.
- 11 Note down the direction of rotation and enter it in Table 1.

Table 1

Sl. No.	Description	1st Start	2nd Start	3rd Start	Unit
1	Supply voltage				Volts
2	Starting current (Star position)				Amps
3	Running current (Delta position)				Amps

12 Note down the current taken by the motor in running condition and enter the value of the current in Table 2.

Table 2

S.No.	Description	Direction of rotation
1	1st start Connection R to L <sub>1</sub> Y to L <sub>2</sub> B to L <sub>3</sub>	
2	2nd start Connection R to L <sub>2</sub> Y to L <sub>1</sub> B to L <sub>3</sub>	
3	3rd start Connection R to L <sub>2</sub> Y to L <sub>3</sub> B to L <sub>1</sub>	

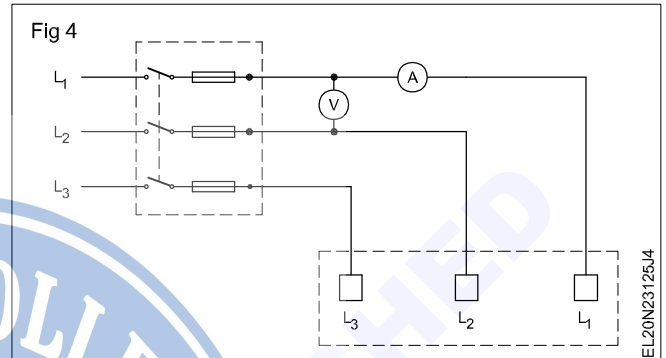

13 Stop the motor by pressing the stop-button of the starter.

14 Switch 'OFF' the main switch and remove the fuses.

15 Interchange the two line cables 'R' and 'Y' to terminals L<sub>2</sub> and L<sub>1</sub> respectively as shown in Fig 1.

16 Insert the fuse-carriers in the main switch.

17 Repeat steps No.9 to 12 and record the information in Tables 1 and 2.

18 Stop the motor, switch off the supply and remove the fuse; then interchange the line cables 'Y' and 'B' terminals L<sub>3</sub> and L<sub>1</sub> respectively. (Fig 2)

19 Insert the fuse-carriers in the main switch.

20 Repeat steps Nos.13 to 16 and record the information in your notebook.

21 Stop the motor and write your observations about the method of changing the direction of rotation.

\_\_\_\_\_

\_\_\_\_\_

22 Switch 'off' the mains, remove the fuse-carriers and remove all connections.

### TASK 3 : Connect and run 3-phase induction motor through auto-transformer starter operated by contactors

1 Check the insulation and continuity of three-phase induction motor.

2 Check the earthing connection for its effectiveness.

3 Examine the diagrams. (Fig 1 and 2) What the following symbols in the diagram indicate? Write your response in the space provided).

4 Draw the power lines connecting the contactors, auto-transformer and motor for sequential operation.

5 Mark the different terminals of contactors corresponding to the actual panel provided.

6 Draw the control circuit connections including timer and overload trip for sequential operation.

**Get the circuit checked by the instructor before proceeding.**

7 Make connections as per diagram.

8 Switch on S1. Switch on the contactor.

9 Check when the full voltage to the induction motor is given by the auto-transformer.

10 Measure rpm of the induction motor.

11 Switch 'OFF' the contactor and then the S<sub>1</sub>.

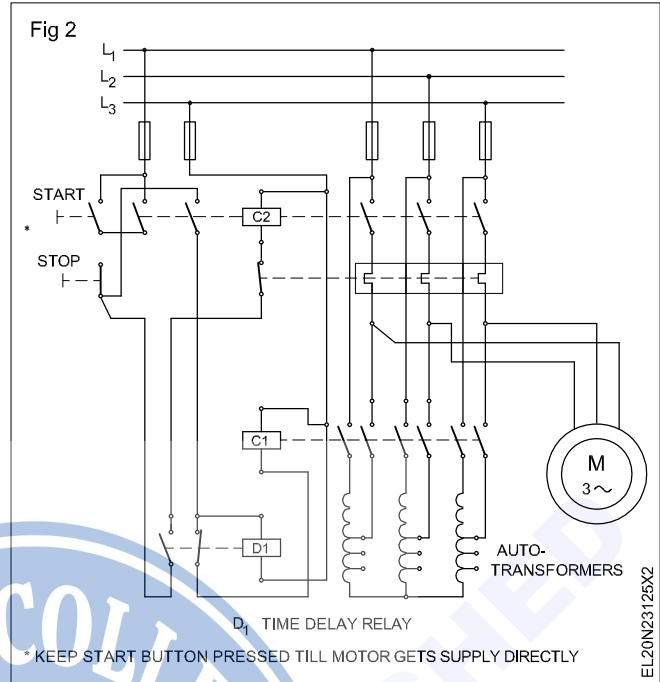
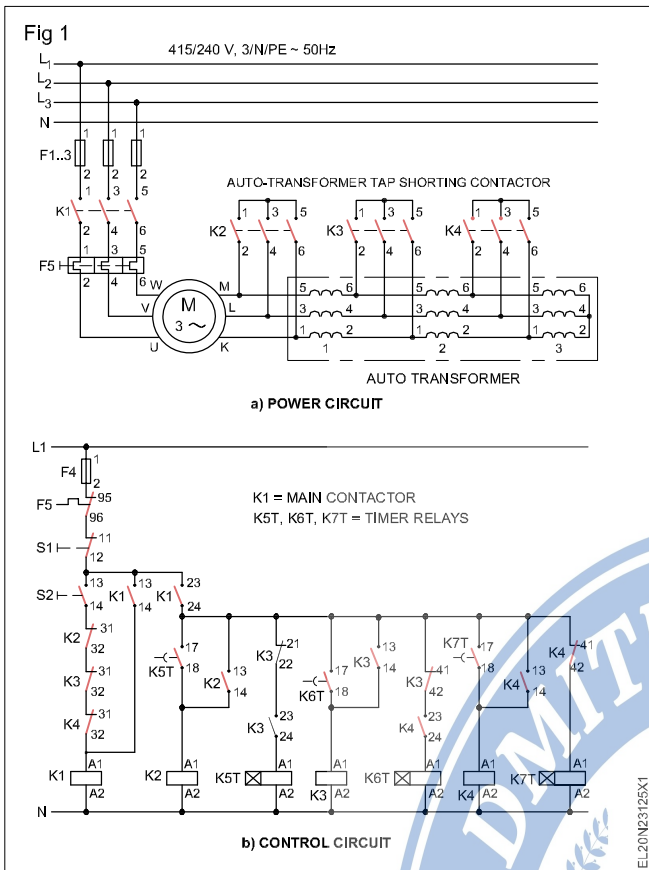

A New type of starter s given below for trainees reference.

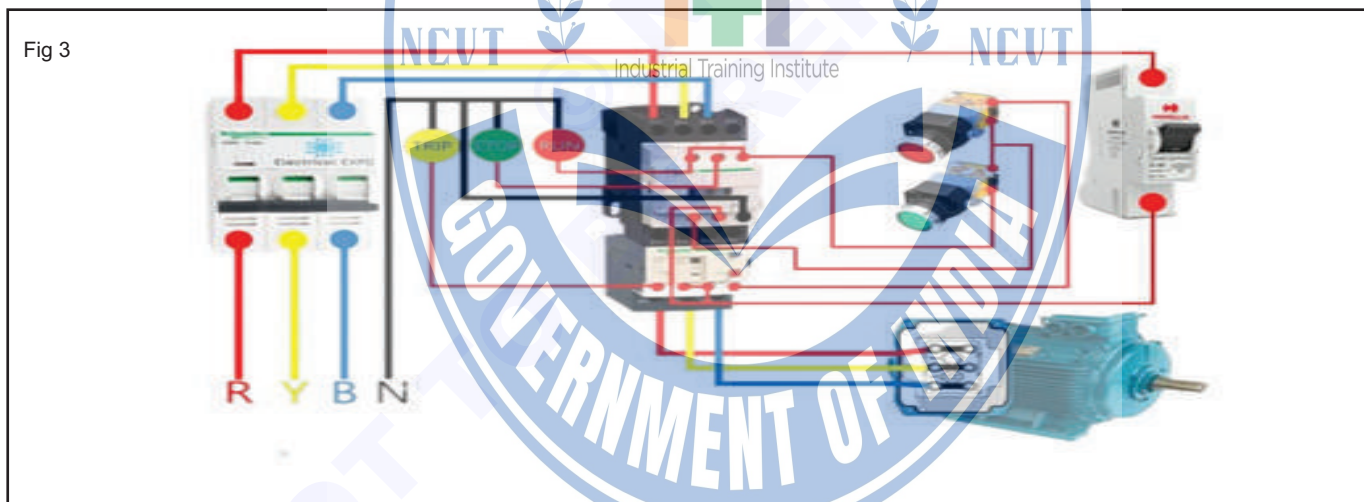

**Connect, start, run and reverse direction of rotation of slip-ring motor through rotor resistance starter and determine performance characteristic**

**Objectives:** At the end of this exercise you shall be able to

- read and interpret the name-plate details of a 3-phase slip-ring induction motor
- identify the parts of a rotor resistance starter, trace the circuit and investigate the operation
- connect the 3-phase, slip-ring induction motor through the rotor resistance starter, start and run the motor
- measure the starting and running current and speed
- reverse the direction of rotation
- load a 3 phase slip ring induction motor and measure the slip.

Requirements	
<b>Tools/Instruments</b>	
<ul style="list-style-type: none"> <li>• Insulated cutting pliers 200mm - 1 No.</li> <li>• Connector screwdriver 100mm - 1 No.</li> <li>• Electrician's knife 100mm - 1 No.</li> <li>• Screwdriver 200mm - 1 No.</li> <li>• MI Voltmeter 0-500V - 1 No.</li> <li>• Tachometer 300 r.p.m to 3000 r.p.m - 1 No.</li> <li>• MI Ammeter 0-20A, 0-10A - 1 each</li> <li>• Megger 500V - 1 No.</li> <li>• MI Ammeter centre zero 5-0-5A - 1 No.</li> </ul>	<ul style="list-style-type: none"> <li>• Rotor resistance starter, complete set, suitable for 5HP 415V 3-phase slip-ring induction motor - 1 Set</li> <li>• Mechanical loading arrangement complete set - 1 Set</li> </ul>
<b>Equipment/Machines</b>	
<ul style="list-style-type: none"> <li>• AC 3-phase, slip-ring induction motor 415V, 5HP, 50Hz - 1 No.</li> </ul>	<b>Materials</b> <ul style="list-style-type: none"> <li>• PVC insulated, stranded aluminum cable 2.5 sq.mm - 15 m</li> <li>• PVC insulated, flexible cable 14/0.2mm - 2 m</li> <li>• Black insulation tape - 0.2m</li> <li>• G.I. wire 8 SWG - 10 m</li> </ul>

**PROCEDURE**

**TASK 1: Connect start, run and reverse the slip-ring induction motor through rotor resistance starter**

- 1 Record the name-plate details of the given motor and the starter.
- 2 Identify the terminals of the 3-phase, slip-ring induction motor.
- 3 Open, identify and trace the internal connections of the rotor resistance starter, draw the diagram and get it approved by the instructor.
- 4 Draw the circuit diagram connecting the ICTP, starter, rotor-resistance and the motor, and get it approved by the instructor.
- 5 Connect double earth independently for the main switch starter and the motor. (Use G.I wire No.8 SWG as earth wire)
- 6 Connect the motor, starter, main switch meters as per the approved diagram (Fig 2) and get it checked by the instructor.

**Slip-ring terminals can be identified by checking the continuity from terminals to the slip-ring.**

- 7 Keep the rotor resistance starter handle in the starting position (cut in) of the rotor resistance.
- 8 Press the start-push button of the starter. While pressing the start-push button, slowly move the handle of the rotor resistance from the starting position towards the running position till it settles down at 'run' position.
- 9 Note down the reading of the voltmeter, ammeter at the time of just starting and normal running positions. Record them in Table 1.
- 10 Release the pressure from the start-push button.
- 11 Note down the direction of rotation. The direction of rotation is .....

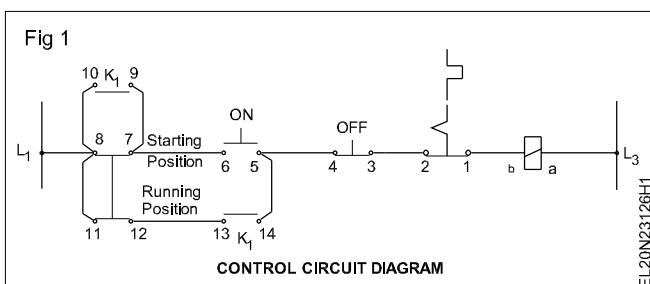

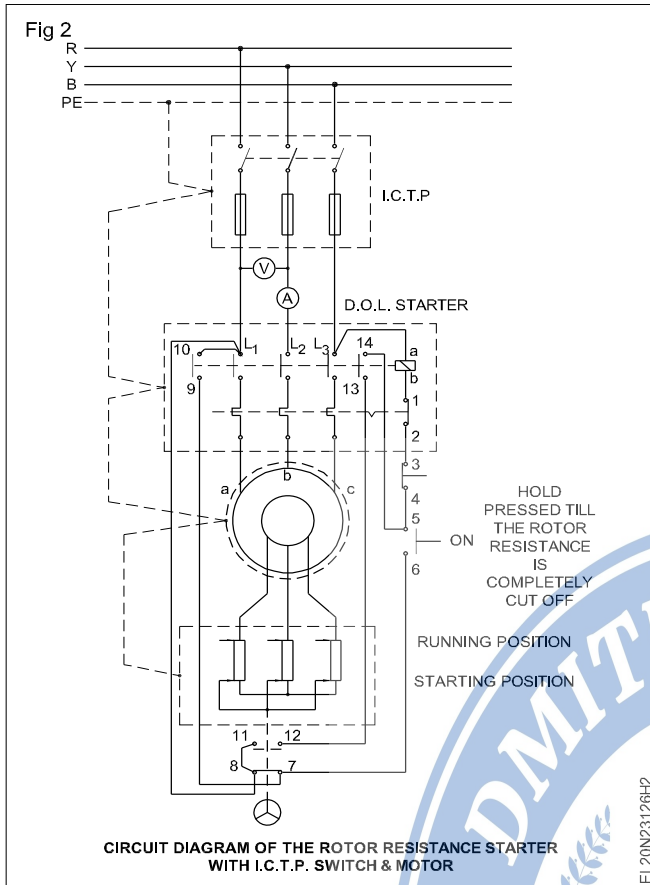

12 Measure the speed and enter in Table 1.

13 Press the 'OFF' button of the starter to stop the motor.

14 Do not start the motor when the rotor-resistance handle is in the running position. The motor starts only when the rotor-resistance handle is in the starting position. (Fig 2) The motor will not start in any intermediate position or in the running position.

Investigate the following:

- Whether the motor could be started when the rotor resistance handle is at the running position.
- Whether the motor could be started when the rotor resistance handle is at an intermediate position between the starting and running positions.
- Whether the motor could be started when the rotor resistance handle is at the starting position.

Write your conclusion.

Table 1

(L-with air gap)

Measured resistance = \_\_\_\_\_ ohms

SI. No	Line voltage in volts	Starting current in amp	Running current in amp	Full load current as shown in the name plate in amps	Speed rpm

### Change DOR

15 Switch OFF the ICTP switch and make sure the supply is disconnected, and the fuses are removed and kept in safe custody.

16 Interchange any two of the line wires, either in the starter terminal or in the motor terminals.

17 Replace the fuses, switch 'ON' the mains and run the motor, observe and record the direction of rotation. The direction of rotation is .....

18 Stop the motor, switch 'off' the mains, remove the fuses and disconnect the cables.

Change either the outgoing cable of switch ICTP or the incoming cables of the starter, whichever is easier.

**TASK 2 : Determine the performance characteristics of a slip ring induction motor**

- 1 Make the connections as per diagrams shown in Fig 1 & 2.
- 2 Check and ensure the control circuit wiring of the starter panel is same as Fig 4.

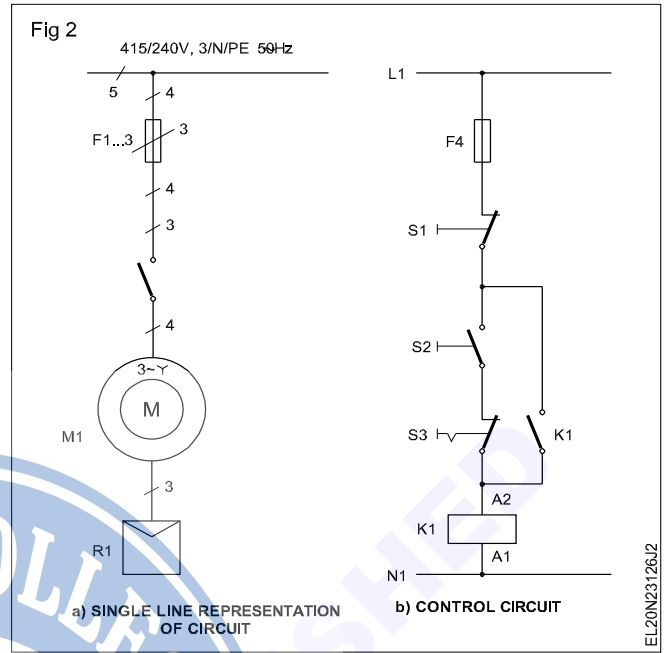
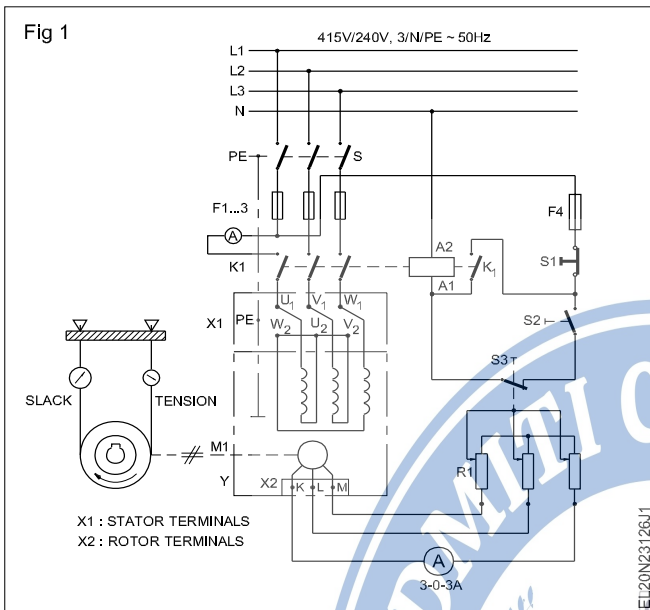

- 3 Check the supply voltage for the rated value and switch on the ICTP switch.
- 4 Start the motor on no-load.

**Make sure the rotor resistance starter handle is in the starting position. Otherwise the motor will not start.**

- 5 Cut down the rotor's circuit resistance to zero gradually observing the increasing speed of the motor.
- 6 Watch the deflections of the ammeter pointer in the rotor circuit and note that it oscillates on either side.
- 7 Start the stop watch and measure the oscillations of the ammeter pointer for one minute and record in Table 2.

- 8 Load the motor with a brake load to about 25%, 50%, 75% & 100% and record the number of oscillations of the ammeter per minute in each case. (Table 2)

**The load on motor is determined by the current taken by it from supply.**

- 9 Determine the rotor current frequency at standstill is equal to the supply frequency to the stator.

Rotor current frequency ( $f_r$ ) while running is supply frequency  $f_r = s \times f$

- 10 Apply the formula

$$\text{Slip} = \frac{\text{rotor frequency } f_r}{\text{supply (stator) frequency } f}$$

Table 2

Load current in Ampere	Ammeter Oscillation	Oscillation per second	Slip ( $S = f_r/f$ )
No load			
About 1/4 FL			
About 1/2 FL			
About 3/4 FL			
Full load			

**Determine the efficiency of squirrel cage induction motor by brake test**

**Objectives:** At the end of this exercise you shall be able to

- connect and conduct the test for actual loading with brake
- calculate the output from the readings of the spring balance
- calculate the efficiency of the motor
- draw the graph of load versus efficiency.

Requirements	
<b>Tools/Instruments</b> <ul style="list-style-type: none"> <li>• Tachometer: multi-range 300 to 3000 r.p.m</li> <li>• MI Voltmeter (0 - 500V)</li> <li>• MI Ammeter (0 - 10A)</li> <li>• Wattmeter dynamometer type 500V, 10A, 3000W</li> <li>• Spring balance 10 kg</li> </ul>	<b>Equipment/Machines</b> <ul style="list-style-type: none"> <li>• 3-phase squirrel cage induction motor 415V, 3 HP 50Hz - 1 No.</li> <li>• Brake loading arrangement DOL starter 415V AC 3-phase, 50Hz, 10A - 1 No.</li> <li>• Connecting cables - as reqd.</li> <li>• ICTP switch 16A, 415V - 1 No.</li> <li>• Graph sheet (A4 Size) - 1 No.</li> </ul>

**PROCEDURE**

- 1 Note the name-plate details of the squirrel cage induction motor.
- 2 Select the voltmeter, ammeter and wattmeter range suitable to the specification given in name-plate details. Make connection as per circuit diagram. (Fig 1)
- 3 Fix the brake drum's rope or belt with the spring balances in slack condition.
- 4 Switch 'ON' ICTP switch 'S' and start the motor at no-load.
- 5 Measure the speed and record in Table 1.
- 6 Tighten the belt to apply brake action on the brake drum, until the motor takes 1/4 full load current.

**Check the mounting of the motor to the base is firm. Check the brake drum is properly keyed to the shaft.**

Fig 1

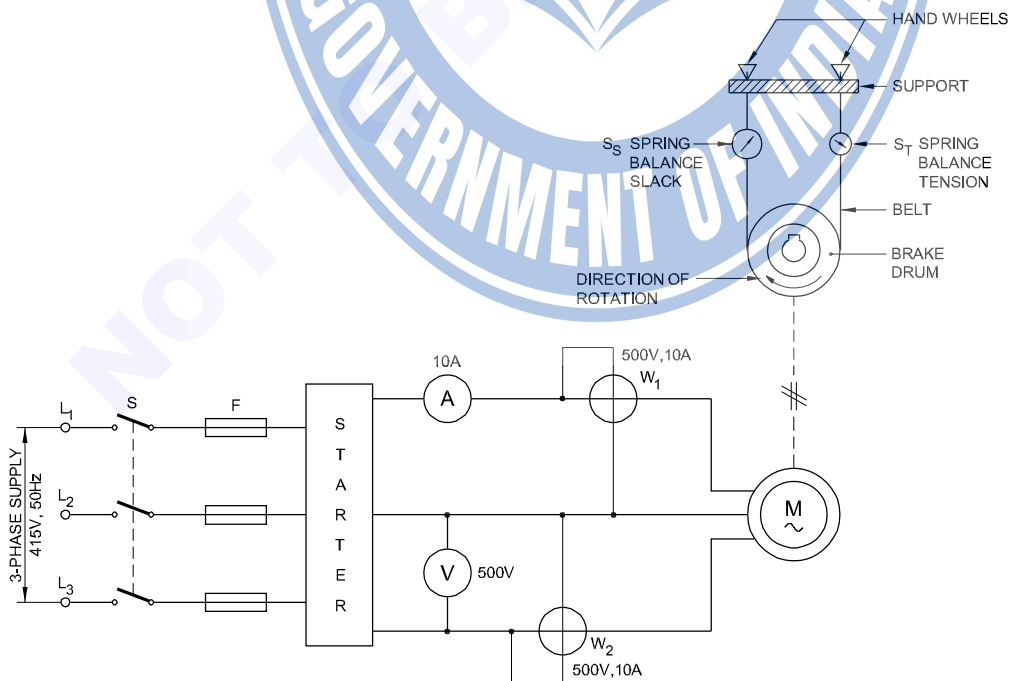

EL20N23127H1

**Apply and regulate the required amount of cooling water to the brake drum.**

- 7 Read the spring balances (Tension side  $S_T$ , slack side  $S_S$ ) and record in Table 1.
- 8 Record the voltmeter, ammeter and wattmeter readings in Table 1.
- 9 Measure the speed of the motor at this loaded condition and record in Table 1.
- 10 Repeat the steps 6 to 9 for different load currents, say about 1/4, 1/2, 3/4 and full load.
- 11 Measure the diameter of the brake drum and the thickness of the rope/belt.
- 12 Drum radius 'R' = \_\_\_\_\_ m.  
Rope/belt thickness 't' \_\_\_\_\_ m
- 13 Calculate the torque

$$\text{Torque, } T = (S_T - S_S) \times (R + t) \text{ Kg m}$$

where (R + t) is in metre, ( $S_T - S_S$ ) is in Kg.

Record the torque and output in Table 2.

- 14 Calculate the output applying the formula,

$$\text{Output} = 1.027 NT \text{ watt}$$

where N - revolutions per minute, T - torque in Kg m

- 15 Calculate the motor input and record in Table 2.

$$\text{Input} = (W_1 + W_2) \text{ watt}$$

- 16 Calculate the efficiency of the motor and record.

$$(\text{Efficiency} = \text{Output}/\text{Input})$$

- 17 Plot the graph for the relationship - load in KW versus efficiency in %.

**Conclusion**

Efficiency of induction motor. \_\_\_\_\_

Table 1

S No.	Speed in rpm	Reading of spring balance tension		Volt meter reading	Ammeter reading	Wattmeter reading
		$S_T$	$S_S$			

Table 2

S No.	Speed	Torque T	Output	Input ( $W_1 + W_2$ )	Efficiency
1					
2					
3					
4					
5					

-----

**Determine the efficiency of 3 phase squirrel cage induction motor by no-load test and blocked rotor test**

**Objectives:** At the end of this exercise you shall be able to

- conduct a no-load test for a given 3-phase squirrel cage induction motor
- conduct blocked rotor test for the above 3-phase squirrel cage induction motor
- determine the constant losses and copper loss at full load.

**Requirements**

**Tools/Instruments**

- MC Voltmeter (0-30V) - 1 No.
- MI Ammeter 0-2.5A - 1 No.
- MI Ammeter 0-2A - 1 No.
- MI Ammeter 0-10A - 1 No.
- Wattmeter 500V, 1A/2.5A low power factor - 2 Nos.
- Wattmeter 125/250V, 10/15A multi range - 2 Nos.
- Voltmeter MI 0-500V - 1 No.
- Voltmeter MI 0-75, 150, 300V multi range - 1 No.

**Equipment/Machines**

- 3-phase induction motor 500V, AC, 50Hz, 3 HP - 1 No.
- DOL starter 500V, AC, 50Hz, 3 HP - 1 No.
- 3-phase auto-transformer input 415V, output 0-500V 3 KVA - 1 No.
- Lock bar/locking arrangement - 1 No.

**Materials**

- Connecting cables - as reqd.
- ICTP switch 16A, 500V - 1 No.

**PROCEDURE**

**TASK 1 : Conduct No-load test**

- 1 Record the name-plate details of the induction motor.
- 2 Collect all the required instruments for the circuit. (Fig 1)
- 3 Make the connections as per circuit diagram. (Fig 1)

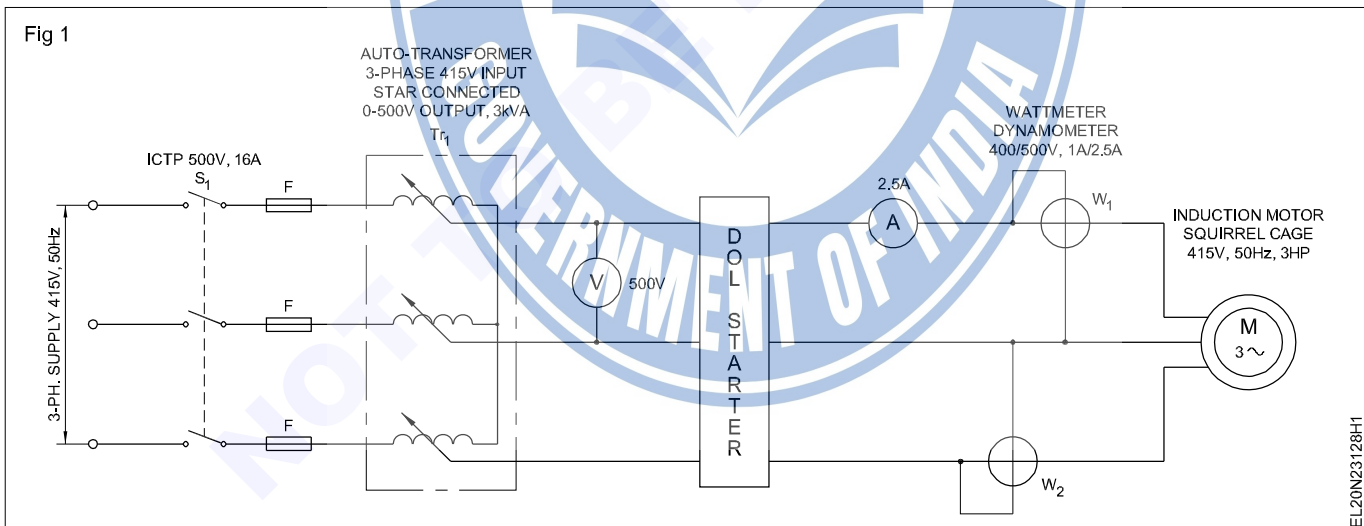

- 4 Check the supply for the rated value and switch 'ON' the ICTP switch ( $S_1$ ) (If the value is not correct adjust by auto transformer)
- 5 Start the motor without any load.
- 6 Read and record the wattmeter, ammeter and voltmeter readings in Table 1.
- 7 Switch 'OFF' the supply and disconnect all connections of the meters, and the motor.

Table 1

Input voltage	Power input $W_o = (W_1 + W_2)$	No-load current $I_o$

- Check the connections of the 3-phase supply leads to the motor terminals. If six terminals are available identify each phase winding.
- Measure the resistance of the stator using DC low voltage supply, ammeter and voltmeter. Record the reading in Table 2.

Table 2

DC supply voltage	Ammeter reading	Resistance of stator (one phase)

- If the motor has only 3 terminals, and the internal connections are marked on the name plate, make calculations as below.

**For star connection**

Resistance per phase  $R_p = \frac{V}{I} \times \frac{1}{2}$

Therefore  $R_p = \frac{R}{2}$

**For Delta connection**

Resistance between two terminals  $R = \frac{V}{I}$

Let the resistance per phase =  $R_p$

$R = R_p \parallel 2R_p$  ( $R_p$  parallel to  $2R_p$ )

i.e  $\frac{1}{R} = \frac{1}{2R_p} + \frac{1}{R_p}$

Resistance measured =  $\frac{2}{3}R_p$

Therefore  $R_p$  (resistance per phase of stator) is =  $\frac{2}{3}R$

Calculations

The no-load input:  $W_o =$  No load copper loss

=  $(I_{oph}^2 R_p) \times 3$

( $I_{oph}$  = no load phase current)

For star connected motor  $I_o = I_{oph}$

For delta connected motor  $I_{oph}^2 = \frac{I_o^2}{\sqrt{3}}$

The losses at no load are

- $I^2 R$  loss in the stator winding
- Core losses in the stator and rotor
- friction and windage losses

**Core losses and friction and windage losses practically remains constant in induction motor**

Constant losses =  $W_o - (I_{oph})^2 R \cdot 3$

**TASK 2 : Conduct blocked rotor test**

- Collect the instruments to form circuit as per diagram. (Fig 1)
- Make the connections as per circuit diagram. (Fig 1)

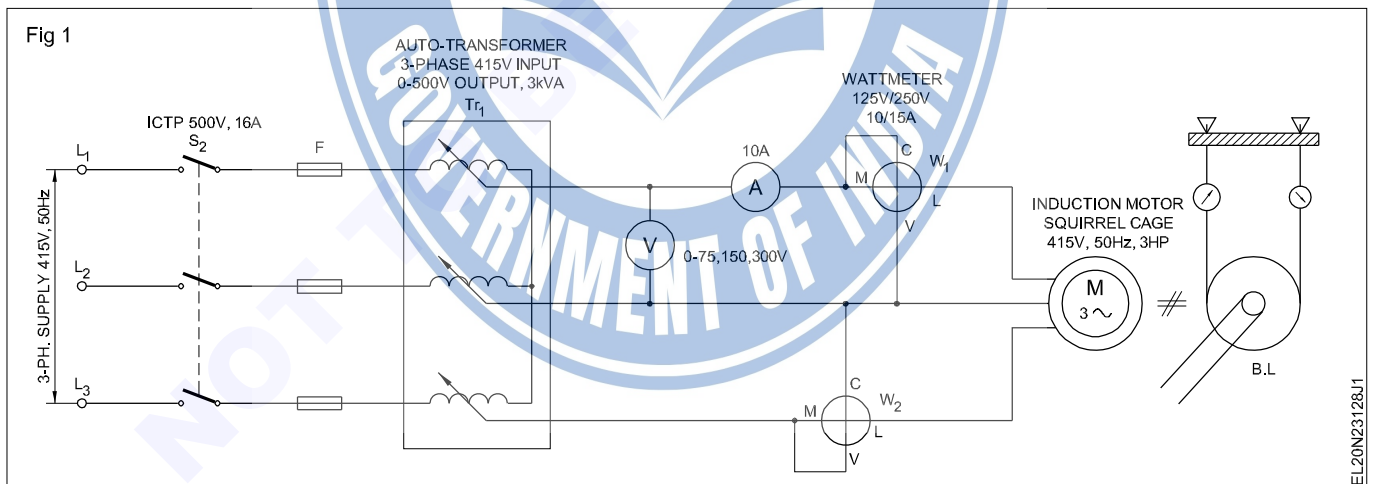

**Keep the auto-transformer at zero output voltage position.**

- Switch on ICTP switch ' $S_2$ '.
- Increase the output of the auto-transformer voltage gradually, watching the ammeter, till the current is equal to full load current.

- Read and record the wattmeter, voltmeter and ammeter readings in Table 3.

Table 3

Input voltage V	Power input W	Blocked current I

### Calculation

Wattmeter reading = full load  $I^2R$  loss.

$$= 3I_p^2 R_e,$$

where  $R_e$  = Resistance of stator winding per phase

$$\text{Wattmeter reading} = 3I_p^2 R_e,$$

$$I^2R \text{ at no load} = 3I_o^2 R_e$$

Magnetic losses = No load input – copper loss.

Total loss = full load  $I^2R$  loss + Magnetic losses

= Block rotor wattmeter reading + Magnetic losses

$$\text{Efficiency} = \frac{\text{Output}}{\text{Input}} = \frac{\text{Input} - \text{Losses}}{\text{Output} + \text{Losses}}$$

Determine the efficiency of the motor at full load.

### Constant losses

= Copper loss at full load =  $3I_p^2 R_e$  watts

where  $R_e$  – equivalent resistance/phase

$I_p$  – full load current/phase

Copper loss at full load = \_\_\_\_\_ watts.

### Input

$$= \sqrt{3} \times V \times I \times \text{pf} = \text{_____ watt.}$$

Total losses = constant losses + copper loss

Therefore, efficiency = \_\_\_\_\_

6 Determine the efficiency when the input current is 0.7 full load and p.f is 0.8.

### Conclusion

---

---

---

---

---

---



**Measure slip and power factor to draw speed torque (slip/ torque) characteristics**

**Objectives:** At the end of this exercise you shall be able to

- wire up and connect resistance starter
- start, run the slip ring induction motor
- plot the graph of speed torque characteristic of slip ring induction motor.

Requirements	
<b>Tools/Instruments</b>	
<ul style="list-style-type: none"> <li>• MI Ammeter 5/10A multirange - 1 No.</li> <li>• MI Voltmeter 250/500V multirange - 1 No.</li> <li>• Tachometer multi-range 300, 1000, 3000 rpm - 1 No.</li> </ul>	<ul style="list-style-type: none"> <li>• 3-phase slip ring induction motor, 3HP, 415V, 50 Hz with rotor resistance starter - 1 No.</li> </ul>
<b>Equipment/Machines</b>	
<ul style="list-style-type: none"> <li>• 3-phase auto-transformer input 415V star connected, output 0-500V, 3kVA - 1 No.</li> </ul>	<b>Materials</b> <ul style="list-style-type: none"> <li>• ICTP switch 16A 415V - 2 Nos.</li> <li>• Connecting cables - as reqd.</li> <li>• Graph sheet (A4 Size) - 1 No.</li> </ul>

**PROCEDURE**

- 1 Read the name-plate details of slip ring induction motor.  
Select the instruments of suitable range to form the circuit as per diagram. (Fig 1)
- 2 Make the connections as per circuit diagram (Fig 1) and Set the output of three-phase auto-transformer to minimum.
- 3 Switch on ICTP (S<sub>1</sub>) and adjust the output of the 3-phase varies to 40% of the rated input voltage of the motor.

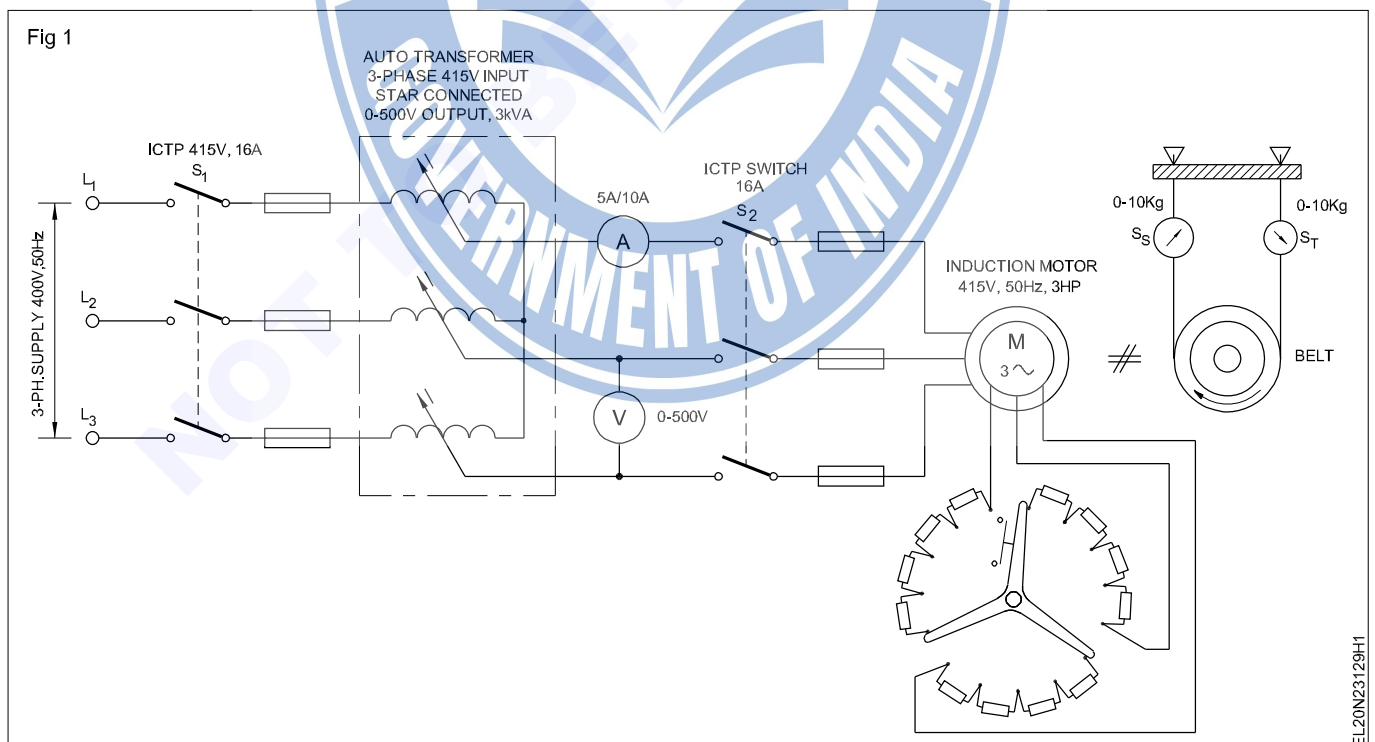

EL20N23129H1

- 4 Check the load on the brake drum which is totally removed.
- 5 Set the rotor resistance starter not to include any resistance in the rotor circuit (i.e rotor terminals are shorted by the starter).
- 6 Close the switch  $S_2$  and start the motor.
- 7 Measure the speed, current and record in Table 1

Table 1

	Stator input voltage	Stator current	Speed	Slip	$S_T$	$S_s$	Motor output torque
Without extra resistance in rotor circuit							
With additional resistance in rotor circuit							
-do-							
-do-							

- 8 Load the motor by adjusting the spring tension of the belt on the brake drum/pulley until the speed falls to a very low value.
- 9 Check the speed, stator current, voltage for each setting of a load and record in Table 1.
- 10 Remove the load on the motor and allow it to run in no load condition.
- 11 Increase the resistance in the rotor circuit by adjusting the rotor starter handle in two or three steps and repeat steps 7 to 10.
- 12 Apply the formula and calculate the torque.

$$\text{Torque (T)} = (S_T - S_s) (R + t)$$

where

$S_T$  - spring balance reading on tension side in kg

$S_s$  - spring balance reading and slack side of belt in kg

R - radius of Drum/pulley in metre

t - thickness of belt in millimetre

- 13 Record the calculated value of torque and slip in Table 1.
- 14 Plot the graph of speed/slip - torque for each rotor resistance.

### Conclusion

Industrial Training Institute

---



---



---



---



---

**Test for continuity and insulation resistance of three phase induction motors**

**Objectives:** At the end of this exercise you shall be able to

- perform insulation resistance test between phase windings
- perform insulation resistance test between winding and body.

Requirements			
<b>Tools/Instruments</b>			
• D.E spanner 5mm to 20m	- 1 Set	• M.I voltmeter 0-50V	- 1 No.
• Cutting pliers 150mm	- 1 No.	• M.I voltmeter 0-25A	- 1 No.
• Screwdriver 200mm	- 1 No.	<b>Equipment/Machines</b>	
• Megger 500V	- 1 No.	• AC 3-phase, 415V / 3 H.P. squirrel cage induction motor	- 1 No.
• Ohmmeter low range 0-10 Ohm	- 1 No.	<b>Materials</b>	
• Test lamp 240V, 60W	- 1 No.	• Connecting cables 2.5 mm <sup>2</sup> of length 40m	- 1 No.
• Earth tester with spikes and connecting lead	- 1 Set	• Connecting cables 2.5 mm <sup>2</sup> of length 10m	- 1 No.
• Hammer straight peen 1.5kg	- 1 No.	• Testing prods	- 1 Pair
• M.C voltmeter 0-10V	- 1 No.		
• M.C ammeter 0-20A	- 1 No.		
• Calibrated rheostat 0.1 ohm, 10 amp	- 1 No.		
• Battery 6V, 60 A	- 1 No.		

**PROCEDURE**

**TASK 1 : Test the continuity of 3 phase induction motor**

- 1 Note the name-plate details of the induction motor.
- 2 Identify the terminals of the given AC induction motor from the markings.
- 3 Connect the test loads of the megger to the terminals U<sub>1</sub> and U<sub>2</sub>. (Fig 1)
- 4 Rotate the megger at its rated speed and note down the readings in Table 1.
- 5 Repeat the steps 3 and 4 by connecting the megger terminals between V<sub>1</sub> and V<sub>2</sub> and also between W<sub>1</sub> and W<sub>2</sub>. Record the finding in Table 1.

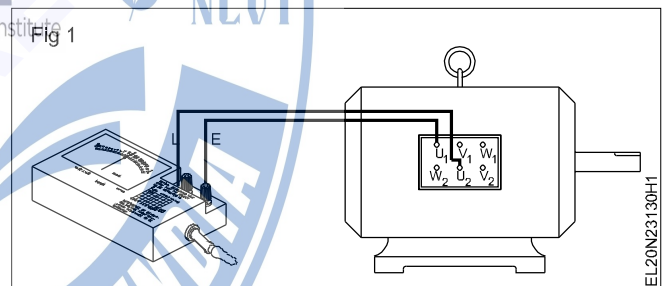

**The megger reading should be zero, if the winding of the motor is having continuity.**  
**The megger reading should be high or infinity (∞) if the winding of the motor is open.**

Table 1

**Continuity test for 3 phase induction motor**

Sl.No	Between terminals	Meter reading	Remarks
1	U <sub>1</sub> and U <sub>2</sub>		
2	V <sub>1</sub> and V <sub>2</sub>		
3	W <sub>1</sub> and W <sub>2</sub>		

## TASK 2: Measure the insulation resistance value between the windings

- 1 Connect the test leads of the megger to the terminals  $U_1$  and  $V_1$ . (Fig 1)
- 2 Rotate the Megger at its rated speed and note down the readings in Table 1.

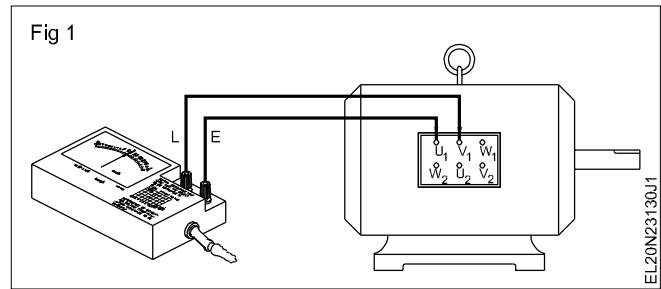

Table 1

Insulation resistance of 3-phase induction motor

SI. No	Between terminals	Insulation resistance	Remarks
1	$U_1$ and $V_1$		
2	$U_1$ and $W_1$		
3	$V_1$ and $W_1$		
4	$U_1$ and frame		
5	$V_1$ and frame		
6	$W_1$ and frame		

- 3 Repeat the steps 1 and 2 by connecting the Megger terminals between  $U_1$  and  $W_1$ , and also between  $V_1$  and  $W_1$ . Record the findings in Table 2.

Recommended standard insulation resistance

$$R_1 = \frac{20 \times E_n}{1000 + 2P} \text{ in megohm.}$$

where

$R_1$  = insulation resistance in megohms at 25°C.



$E_n$  = rated phase-to-phase voltage

$P$  = Rated power in kW.

If the resistance is measured at a temperature different from 25°C, the value shall be corrected to 25°C.

The equation given here is used to calculate the insulation resistance as a standard value. However the accepted insulation value should not be less than 1 megohms.

## TASK 3 : Measure the insulation resistance between each winding and body or frame

- 1 Connect the test leads of the Megger to the frame of the motor and terminal  $U_1$ . (Fig 1)

The Megger connection to the frame should be done at the earthing stud of the frame. Before connecting, remove the varnish, dust, dirt and grit thoroughly at the earthing stud.

- 2 Rotate the Megger at its rated speed and note down the readings.
- 3 Repeat steps 1 and 2 for the other two windings ( $V_1$  and  $W_1$ ).
- 4 Compare the measured value with the standard value.

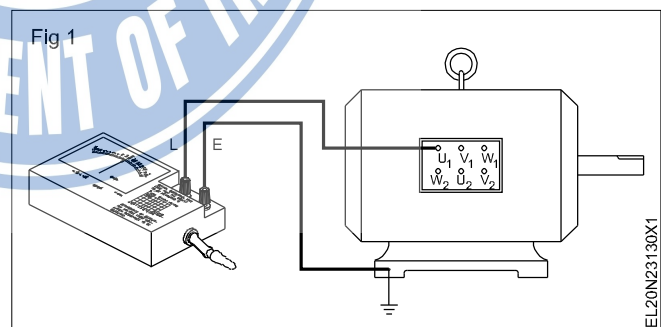

**Perform speed control of 3-phase induction motors by various methods like rheostatic control, auto transformer etc.**

**Objectives:** At the end of this exercise you shall be able to

- connect the 3 phase slip ring induction motor through rotor resistance starter
- control the speed of a 3-phase slip ring motor by rotor resistance starter
- connect a 3 phase induction motor to an auto transformer starter
- control the speed of a 3 phase induction motor by auto transformer starter.

Requirements	
<b>Tools/Instruments</b>	
<ul style="list-style-type: none"> <li>• Insulated cutting pliers 200mm - 1 No.</li> <li>• Connector screw driver 100 mm - 1 No.</li> <li>• Electrician's knife 100 mm - 1 No.</li> <li>• Screw driver 200mm - 1 No.</li> <li>• MI Voltmeter - 0-500 V - 1 No.</li> <li>• Tachometer 300 rpm to 3000 rpm - 1 No.</li> <li>• Megger 500V - 1 No.</li> </ul>	<ul style="list-style-type: none"> <li>• Rotor resistance starter complete set suitable for 3HP - 1 No.</li> <li>• AC 3 phase squirrel cage induction motor 500V, 5 HP - 1 No.</li> <li>• Auto - transformer starter complete set suitable for 5 HP - 1 No.</li> </ul>
<b>Equipment/Machines</b>	
<ul style="list-style-type: none"> <li>• AC 3 Phase slip ring induction motor 415V 3HP - 1 No.</li> </ul>	<ul style="list-style-type: none"> <li>• PVC Insulated flexible cable 2.5 sqmm - 20 m</li> <li>• IC TP switch 10A 500V - 2 Nos.</li> <li>• Test Lamp 40 W 250V - 1 No.</li> </ul>

**PROCEDURE**

**TASK 1 : Control the speed of a slip ring Induction motor by a rotor resistance starter**

- 1 Check the Insulation and continuity of the motor winding.
- 2 Make the connection as per circuit diagram. (Fig 1)
- 3 Check the supply and provide proper rating fuses in the main switch according to the motor rating.
- 4 Keep the rotor resistance starter handle in the starting position (cut in) of the rotor resistance.

**Cut in position of the rotor resistance is generally indicated in the starter as starting position or off position.**

- 5 Press the start button of the starter, while pressing the start push button, slowly move the handle of the rotor resistance from the starting position towards the running position step by step till it settles down at run position.
- 6 Measure the speed at every step of rotor resistance and record them in Table 1.

Table 1

SI No.	Rotor Resistance Handle position	Speed in RPM

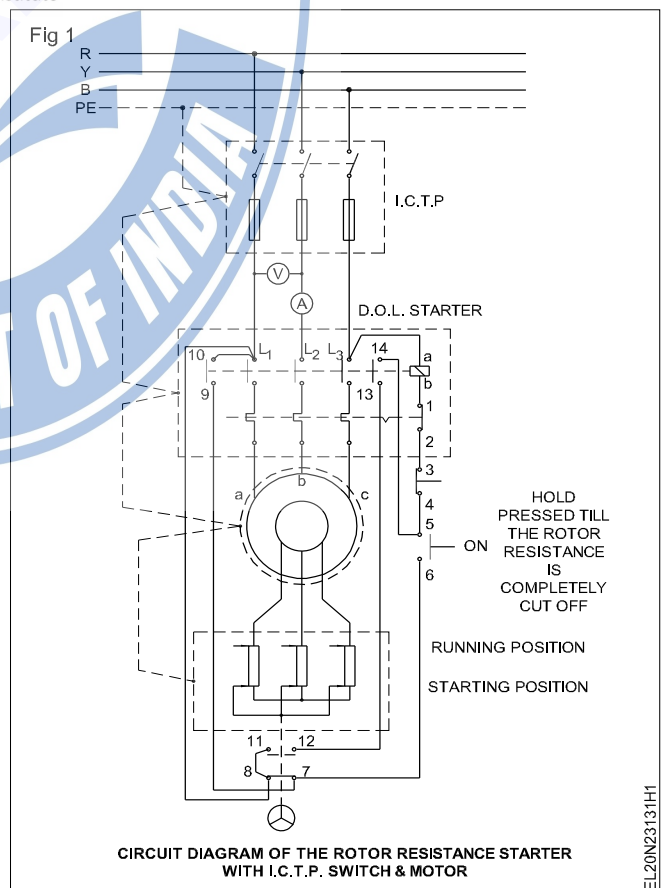

EL20N23131H1

7 Release the pressure from the start push button.

8 Press the off button of the starter to stop the motor.

**TASK 2 : Control the speed of 3-phase Induction motor by an auto transformer starter**

- 1 Check the insulation and continuity of the motor winding.
- 2 Make connections as per diagram. (Fig 1)

- 3 Switch on the main switch 'S1' and then press start push button. (keep auto-transformer for 100V output)
- 4 Start moving the auto transformer starter contacts such that the induction motor will start getting more voltage in stages upto full voltage.
- 5 Note the speed and voltage at every stage.
- 6 Reduce the applied voltage to the induction motor by resetting the auto-transformer contacts.
- 7 Measure the rpm of the induction motor at every stage and note in Table 2.

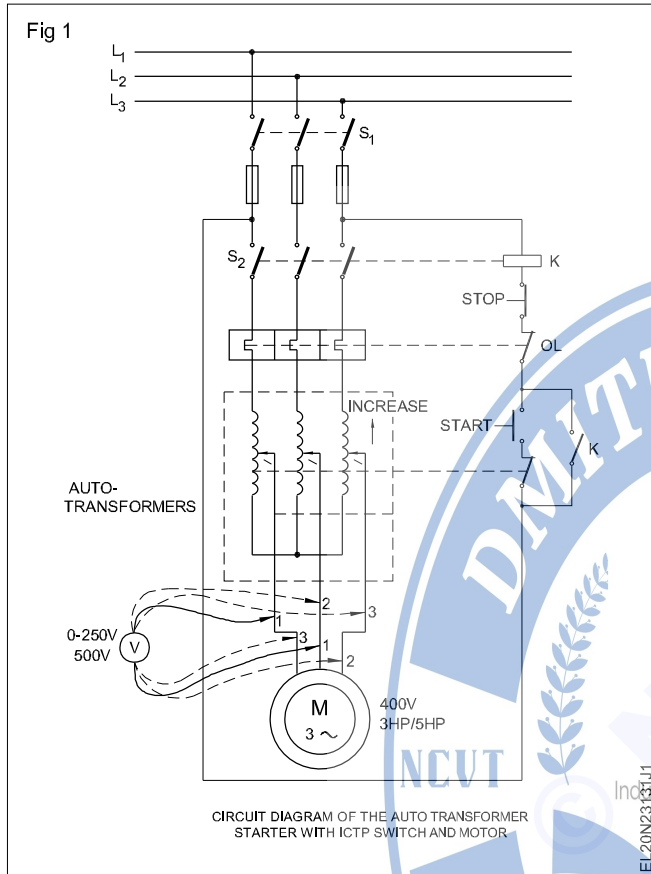

Table 2

Sl.No.	Line voltage (V1)	rpm

- 8 Switch off by pressing stop button and then switch off the main switch (S1)

**Conclusion**

State in what proportion the speed changes with respect to applied voltage to induction motor.

**Get the circuit checked by the instructor before proceeding.**

## Electrician - AC Three Phase Motor

## Perform winding of three phase AC motor by developing connection diagram, test and assemble

**Objectives:** At the end of this exercise you shall be able to

- dismantle the motor
- read, record and interpret the winding data for a 3-phase squirrel cage induction motor
- strip the old winding from the stator
- prepare and provide slot insulation
- prepare and lay the coils for the distributed type winding, concentric group of coils
- make end connections and terminate the lead wire
- insulate, bind and shape the overhangs
- assemble the motor
- test the motor for performance.

Requirements			
<b>Tools/Instruments</b>			
• Screwdriver 100, 150 and 200 mm	- 1 No each	• Electric air blower	- 1 No.
• DE spanner 5mm to 30 mm	- 1 Set	<b>Equipment/Machines</b>	
• Ring spanner 5 mm to 30 mm	- 1 Set	• Burnt out 3-phase motor with single layer distributed winding of available capacity & double layer	- 1 No.
• Cold chisel 25 mm x 200 mm	- 1 No.	• Baking oven with temperature control	- 1 No.
• Ball pein hammer 500 grams	- 1 No.	• Coil winding machine	- 1 No.
• Nylon mallet 75 mm x 100 mm	- 1 No.	• Burnt out 3 phase motor with single layer concentric half coil winding	- 1 No.
• Pulley puller 200 mm with 3 jaws	- 1 No.	<b>Materials</b>	
• Centre punch 10 mm x 150 mm	- 1 No.	• Super-enamelled copper wire	- as reqd.
• Insulated cutting pliers 200 mm	- 1 No.	• Milinex sheet or triplex paper	- as reqd.
• Side cutter 150 mm	- 1 No.	• 20 or 25 mm cotton tape	- 1 Roll
• Micrometer outside 0-25 mm	- 1 No.	• Fibre glass sleeves 1 mm, 2 mm, 4 mm, 6 mm	- as reqd.
• Hacksaw frame 300 mm	- 1 No.	• Bamboo/fibre wedges	- as reqd.
• Steel rule 300 mm	- 1 No.	• 25 mm painting brush	- 1 No.
• Scissors 200 mm	- 1 No.	• Soldering lead 60%, Tin 40%,	- 100 g
• Fibre or Hylam knife of assorted sizes	- 4 Nos.	• Resin flux	- 25 g
• Soldering iron 125 W, 250V	- 1 No.	• Insulating varnish	- 1 litre.
• D.B.electrician knife 100 mm	- 1 No.	• Tray 600 mm x 600 mm x 100 mm	- 1 No.
• Multimeter	- 1 No.	• Thinner	- 500 ml
• Megger (insulation tester) 500V	- 1 No.	• Hemp thread	- 1 Roll
• Ammeter (or multi-range) M.I. 0-10A	- 1 No.	• Used power hacksaw blade	- 2 Nos.
• Voltmeter M.I. Multi-range 0-300V-500V	- 1 No.	• Leatheroid paper	- as reqd.
• Tachometer 0-500-5000 r.p.m.	- 1 No.	• Empire sleeve	- as reqd.
• Allen key	- 1 Set		
• Readymade former universal size	- 1 Set		
• Awl of required length and thickness	- 1 No.		
• Spatula	- 1 No.		
• Magnetic compass 15 mm dia.	- 1 No.		
• Blow lamp	- 1 No.		

## PROCEDURE

**Instructor may select a motor having burnt out single layer distributed winding for this exercise.**

## TASK 1 : Dismantling of the motor, recording winding data and stripping the winding

- 1 Collect the name-plate details and record.
- 2 Calculate the number of poles from the name-plate details.

$N_s$  - synchronous speed in r.p.m.

(little higher than the rotor speed noted in the name-plate).

3 Enter the number of poles in Table 1.

Using the formula  $P =$

where  $P$  - number of poles  
 $f$  - frequency in Hertz

Table 1

**Winding Data**

No. of coils .....	No. of slots.....	Coil pitch .....
No. of Poles .....		
Overhang projection	a) connection end .....	mm
	b) Non-connection end .....	mm

**Alternatively calculate the poles using the rated rotor speed and round off the value to full number.**

4 Remove the shaft key or the grub screw by holding the pulley. (Fig 1)

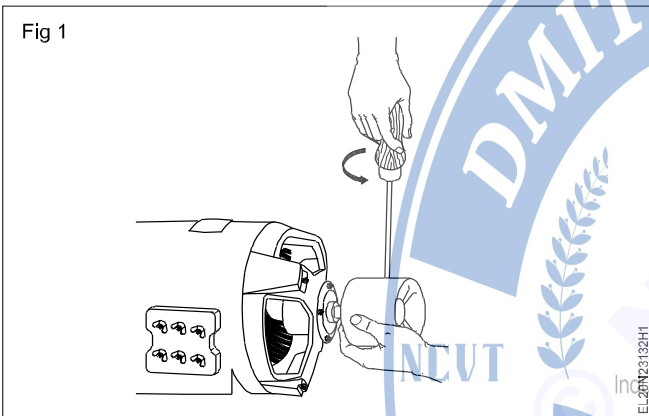

**To avoid confusion make a single punch mark on one side and a dual punch mark on the other end of the motor.**

7 Remove the grease cup screw.

8 Loosen the bolts gradually, switching from side to side till they are removed. (Fig 4)

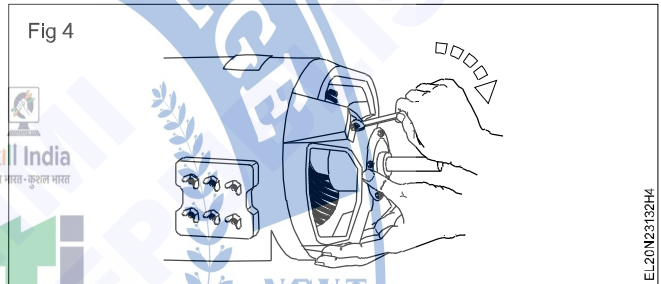

5 Remove the pulley by using a suitable pulley puller. (Fig 2)

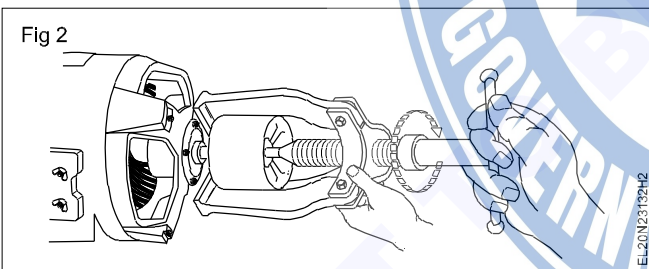

9 Keep the cold chisel tip between the stator and cover and gently tap the chisel with a hammer and separate the stator and the end shield cover. (Fig 5)

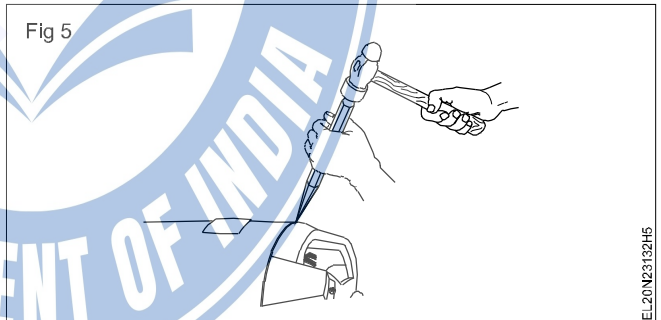

6 Make a centre punch alignment mark on the stator and the end shield cover. (Fig 3)

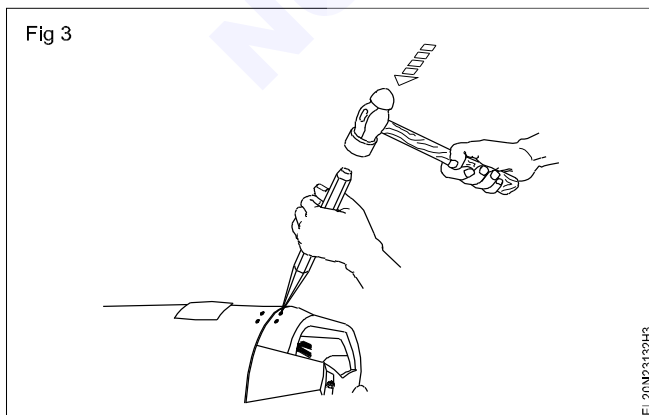

10 Pull off the end shield cover and rotor together, parallel to the motor shaft. (Fig 6)

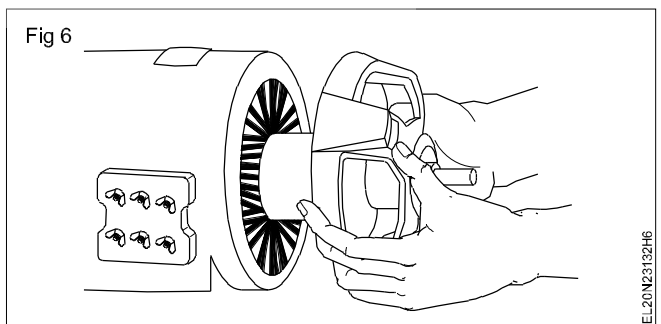

- 11 Hold the shaft in one hand, rotate the end cover and tap it lightly with a nylon mallet to remove it from the rotor. (Fig 7)

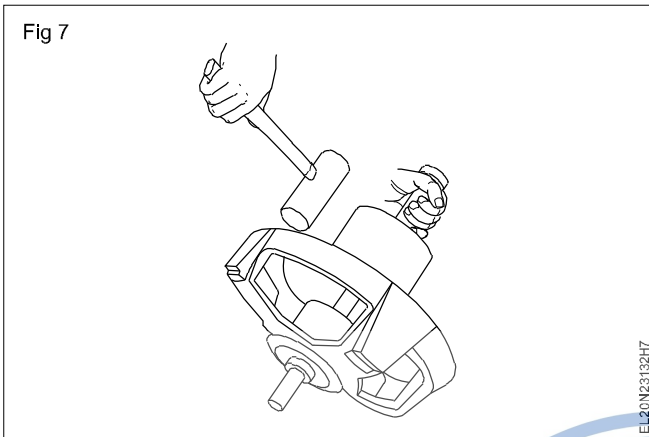

- 12 Remove the other end shield cover also by gently priming it out.  
13 Inspect the rotor for any defect and the bearing for its condition.

**If the bearing is worn out replace it with a new one. All fastening devices should be kept in a separate tray. The dismantle parts are shown in Fig 8.**

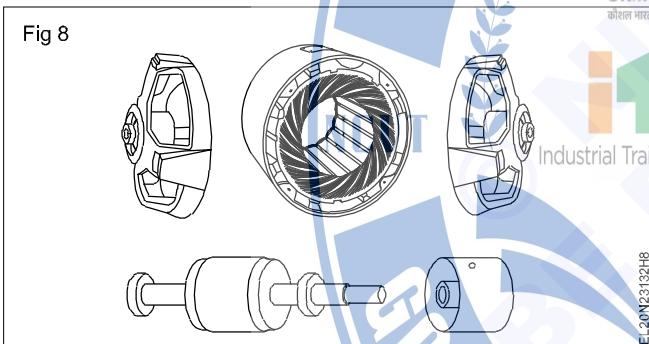

- 14 Identify whether the winding is a single layer distributed type.

**In a single layer distributed type winding, the number of coils is equal to half the number of slots and the same size of coils are used throughout the winding.**

- 15 Record the number of coils, number of poles, number of slots, pitch and record the overhang projection at both ends of the stator in table 2 and if required prepare templates by cardboard or similar materials for overhang projection. This will help to check the overhangs after rewinding.  
16 Open the end binding of the end and lead connections from the overhang.  
17 Trace the group/lead connections and draw the same for reference in your record.

**The number of coil groups shall be equal to the number of phase x number of poles in the case of whole coil connection whereas in the case of half coil connection the number of coil groups shall be equal to the number of phases x pair of poles. Hence ascertain the group and connection.**

- 18 Remove the wedges. The wedge can be removed by using a power hacksaw blade as shown in Fig 9 or by a wedge remover.

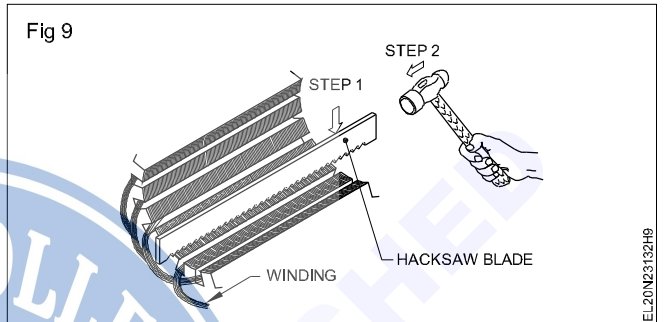

- 19 Cut off the coils in the non-connection end of the stator with a chisel. (Fig 10)

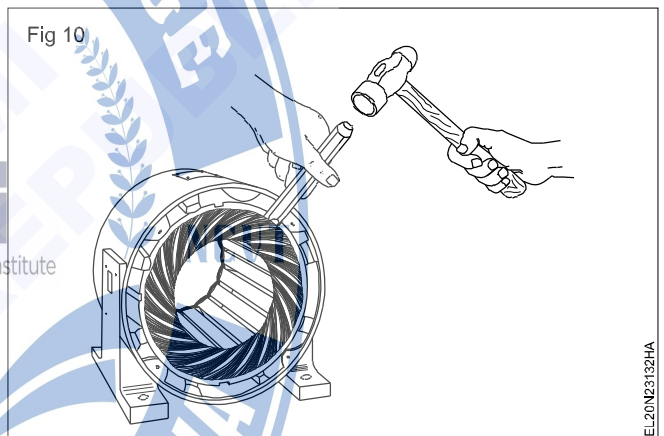

- 20 Pull out the coils with pincers or pliers. (Fig 11)

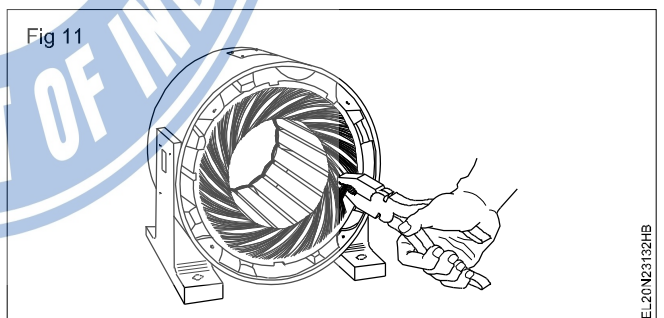

**In case the varnish on the winding is hard, heat the winding in an oven to about 200°C for about one hour or heat it by a blowlamp. While heating it is important that the heat should be controlled such that the excess heat will not damage the stampings and warp the frame or core. In the case of loose coils, cutting of the coils may not be required and it can be removed out through the slots.**

21 Check, record the total weight of the coils, count the number of turns, measure the size of the wire, and record them in Table 2.

23 Clean it by blowing compressed air.

24 Measure the size and shape of the coil. If the full shape of the coil is available record the details in Table 3.

**Some manufacturers may use parallel conductors of the same size or different sizes of wires instead of using a single wire. Take care of this while recording and entering the details in Table 2 against 'wire multiple'.**

**In case the full shape of the coil is not available, prepare a trial coil of single turn and insert it in the slots at the given pitches. Verify the overhang projection, clearance, correct size etc.**

22 Remove all the remaining foreign matter from the slots by scraping with a knife.

Table 2

No. of circuits.....	Turns/Coils.....	Size of the wire.....
Wire multiple.....	Wt.of scrap.....	Wire insulation.....

Table 3

Coil shape: Diamond / Rectangular / Oval	
A.	Coil length ..... mm
B.	Coil width ..... mm

**TASK 2 : Prepare and provide slot insulation**

- 1 Check the slot dimension and record it in Table 4.
- 2 Check the core thickness and record the same in Table 4.
- 3 Select the slot liner of thickness as in the original.
- 4 Cut the paper as per slot length/core thickness with an additional length of 10 to 15 mm so as to make the insulation paper to project 5 mm on either side of the slot with cuffed ends.

7 Insert the slot liners in all the slots properly and see that the slot liners project evenly on both sides of the core. (Fig 2)

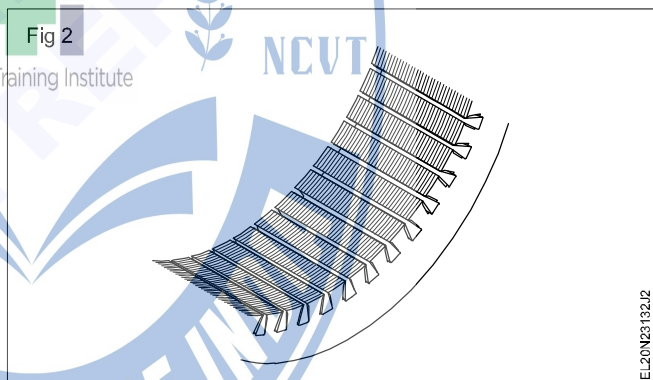

**10 to 15mm on either side is just an approximate requirement. Large motors may require a longer length or vice versa.**

5 Cuff either end of the slot liner (Fig 1) and fold the same to the slot size.

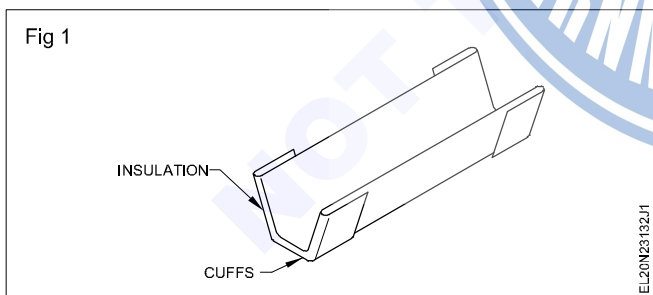

**The slot liner should properly adhere to the surface of the slots as shown in Fig 3(a). A wrong method of placing the slot liner. (Fig 3b).**

**Prepare a sample of the slot liner and try inserting it in the slot to see the correctness.**

6 Cut and prepare the necessary number of slot liners as per the correct sample.

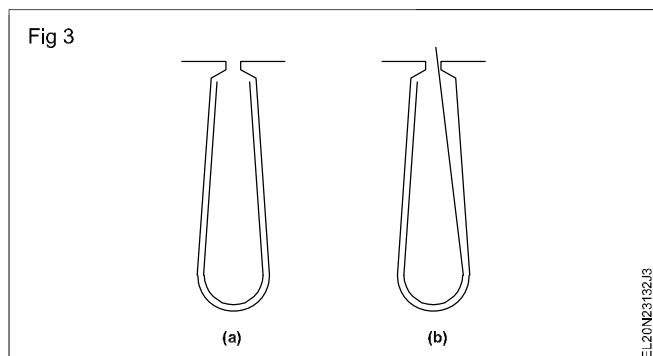

- 8 Check the group/lead connections drawn in step 17 of Task 1 and also draw the developed diagram of the winding for the given motor.

**For your guidance the end connections and the developed diagram are given in Figs 4 and 5 respectively for a certain motor having a single layer distributed type winding with the following data: 24 slots, 12 coils, 4 poles, 3-phase balanced winding.**

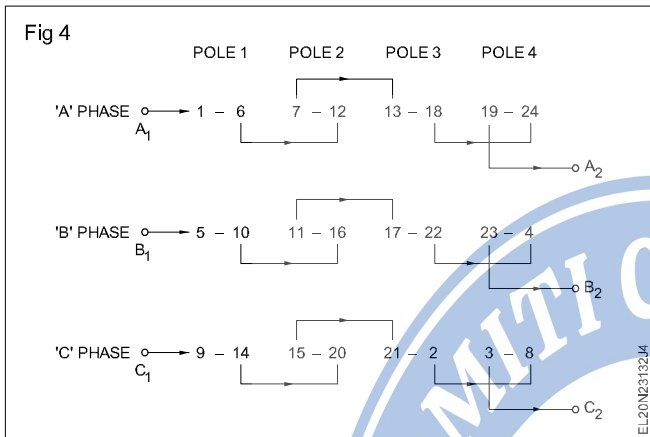
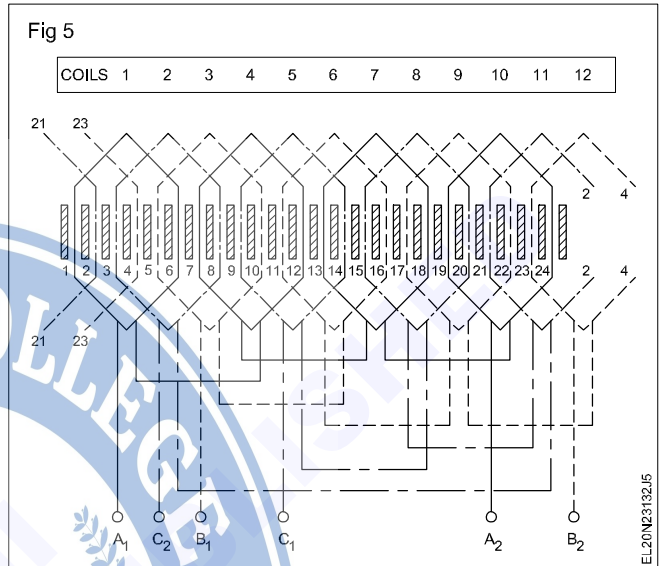

Table 4  
Slot dimension

Lower width	.....mm
Upper width (W)	.....mm
Depth	.....mm
Slot length	.....mm



**TASK 3 : Prepare coil winding and forming**

- 1 Select a suitable size of former according to the dimension recorded in Table 3.

**The former is cut with a distinct bevel edge for two reasons: to permit the coil to slip off the former and to allow a longer peripheral length of the coil at the back. Only one size of former is sufficient for the distributed type of winding.**

- 2 Attach the former securely to the winding stand. (Fig 1).



- 3 Confirm and select the size of winding wire i.e. given in Table 2.  
4 Wind the designated number of turns (Table 3) by leaving 150 mm extension wire.

**Make sure the number of turns is small as in the original.**

- 5 Tie the coil tightly with twine thread on either side of the coil, after winding the coil.  
6 Cut the remaining length of wire by leaving 150 mm extension.  
7 Remove the coil from the former and check its correctness by inserting in the slots.

**If the size is found OK proceed to step 8. Otherwise make necessary changes in the former till the coil shape is correct.**

- 8 Make the required number of coils.  
9 Shape the coils by folding the ends of the straight parts of the coils. (Fig 2)

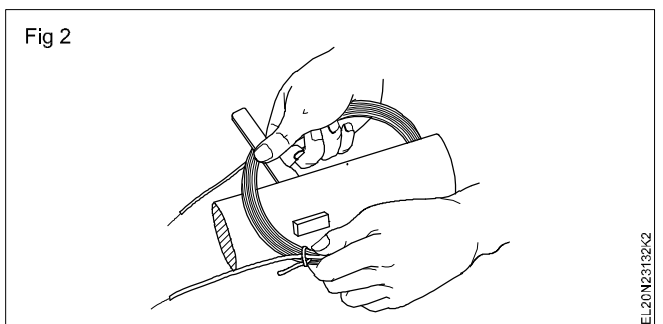

**TASK 4 : Insert the coils in the slots in proper sequence**

**Procedure for 24 slots, 12 coils, 4 pole distributed winding is given below. You can adopt the same procedure for other stators of different slots and poles with necessary modification. Observe keenly the developed diagram shown.**

- Follow the procedure given below. First insert the left coil sides of 1st coil, 2nd coil and 3rd coil in slot 1, 3 and 5 respectively. (Fig 1)

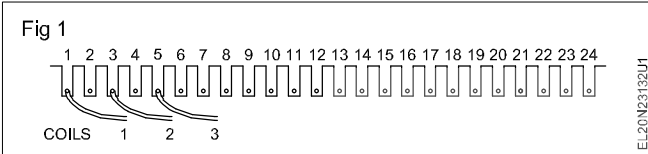

- Insert the right coil side of the 1st coil in slot number 6. (Fig 2)

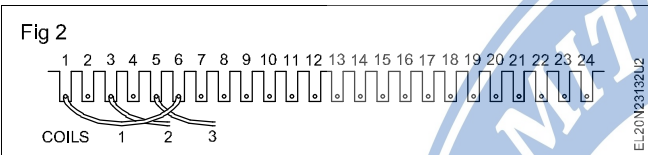

- Insert the left coil side of coil 4 in slot 7 (Fig 3) and then insert the right coil side of coil 2 in slot 8. (Fig 4)

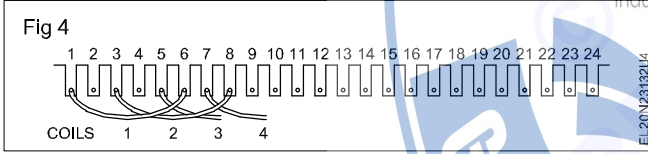
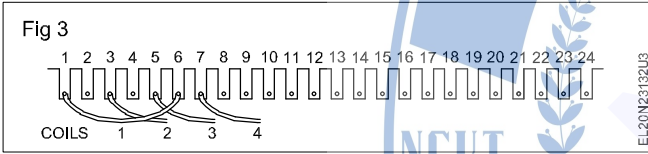

- Insert left coil side of coil 5 in slot 9 and then insert the right coil side of coil 3 in slot 10. (Fig 5)

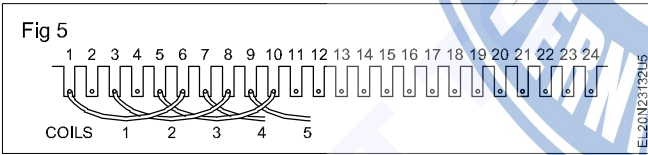

- Proceed likewise till you are left with the right coil sides of coils 11 and 12.

- Insert the 11th coil right coil side in slot 2 and then the 12th coil right coil side in slot 4. (Fig 6)

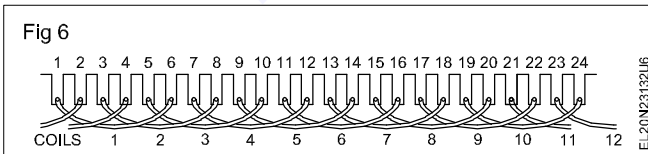

- Insert the wedges in the slots so that the coil sides are well packed in the slots. (Fig 7)

- Insert the half moon shaped phase insulation paper between each coil in both sides of the overhang.

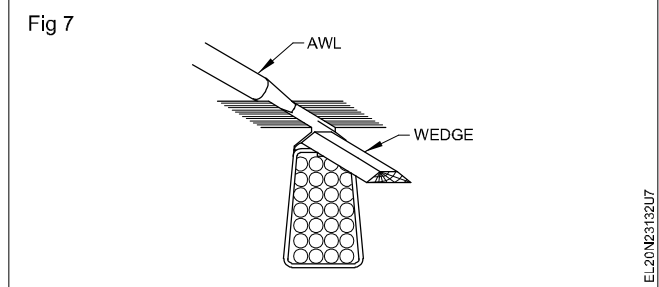

- Follow the developed diagram and connect the end, group and terminal connections.

- Tie the connections with overhangs and shape the overhang.

- Test the winding .

- Measure the resistance between  $A_1 - A_2$ ,  $B_1 - B_2$  and  $C_1 - C_2$  and record the values in Table 5.

Table 5

Resistance between  $A_1 - A_2$  .....ohm

Resistance between  $B_1 - B_2$  .....ohm

Resistance between  $C_1 - C_2$  .....ohm

**All the three resistances should be equal.**

- Measure the insulation resistance between the windings and the stator core with 500 V Megger and record it in Table 6.

Table 6

**Insulation resistance**

between core and A phase.....MEGOHM

between core and C phase.....MEGOHM

between core and B phase.....MEGOHM

- Measure the insulation resistance between the windings with a 500V Megger and record it in Table 7.

**The above values should not be less than one megohm in any case.**

Table 7

**Insulation Resistance**

Between A phase and B phase...MEGOHM

Between B phase and C phase...MEGOHM

Between C phase and A phase...MEGOHM

- Varnish the winding,

- Assemble the motor and test run the motor with load for 8 hours.

**The instructor should select a 3-phase induction motor having a single layer concentric (half coil) winding for this exercise.**

**TASK 5 : Record winding data and strip the winding**

- 1 Collect the name-plate data and record in Table 8.
- 2 From the name-plate details, calculate the number of poles and write it below.  
Number of poles.....
- 3 Dismantle the given motor. Record the details of the existing winding details before and after removing the coils from the stator in Table 12.
- 4 Identify the windings of the given motor - whether it is single layer concentric winding.

Table 8

**Induction motor**

Make .....	Frame No. ....	Model .....
Phase .....	Kilowatt/HP .....	r.p.m .....
Volts .....	Amperes .....	Frequency.....

**In single layer winding, the number of coils is equal to half the number of slots. In concentric winding the pitch of coils in the group will be different and will be in concentric form.**

- 5 Record the number of slots, number of coils and the pitch of the coils in Table 9.

Table 9

No. of slots .....	No. of coils .....	Coil Pitch .....
No. of poles.....	No. of coils/slot .....	
End connections .....	(Half coil/whole coil)	

- 6 Trace the group/lead connections and draw the same for reference in the space given.

**In whole coil connected winding, the total number of groups shall be equal to the number of phases multiplied by the number of poles, and in the case of half coil connected winding, the total number of groups shall be equal to the number of phases multiplied by the number of pairs of poles. Hence ascertain the number of groups, and, thereby, the type of connection.**

- 7 Record the length of the overhang projection and prepare a template which could be used to check the overhangs after rewinding.
- 8 Remove the wedges from the slots.
- 9 Strip all the coils out from the stator except one complete group of coils.
- 10 Use a thinner in the winding and remove carefully one complete group of coils without damage.
- 11 Check the total coil weight and record it in Table 10.

Table 10

No. of circuits.....	Turns/coil.....
a) .....	
b) .....	
c) .....	
Size of the wire.....	Wire multiple.....
Total weight of scraped coils.....	Wire insulation.....

- 12 Clean the stator slots.
- 13 Using the complete set of coils, measure the size and shape of the coils and record the details in Table 11.

Table 11

Shape of the coil.....	diamond/Rectangular/Oval	
	<b>Outer coil</b>	<b>Inner coil</b>
A	Coil length .....	mm .....
B	Coil width .....	mm .....
C	Coil thickness .....	m

**In case the full shape of a coil is not available, use a single turn of 16 or 18 SWG copper wire and measure the inner dimensions of the coils of the coils of the set, one after the other. Insert it in the slots at the given pitches. Verify the length of overhang projection and clearance etc. taking into account the thickness of the coils. If found satisfactory, use the same for recording the measurement.**

**TASK 6 : Prepare slot insulation**

- 1 Prepare slot liners and insulate the slots.

**TASK 7 : Lay coils in the slots**

**The Procedure for 24 slots, 12 coils, 4 poles, single layer concentric winding (half coil) is given below. You can adopt the same procedure for the other stators of different slots and poles with necessary modifications.**

**The end connection and developed diagrams for the above stated winding are given in Fig 1 and 2 for your guidance.**

- 1 Insert the guide papers in the grooves of slot No.2 (Fig 2) where the winding will begin.

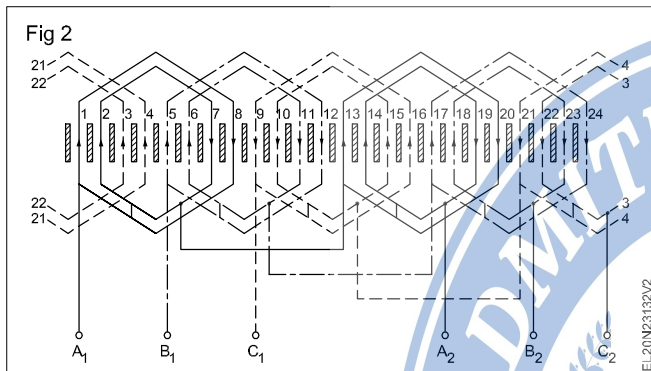
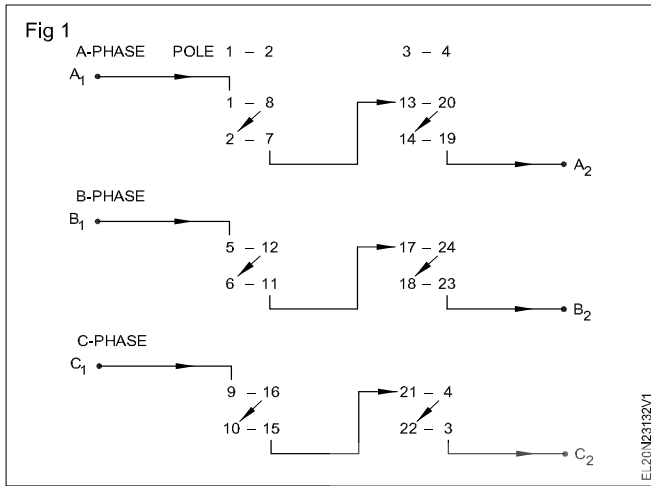

**In the concentric type of winding the insertion of coils should start from the inner coil which is having the shortest pitch.**

- 2 Check the connection side of the winding with respect to the stator and hold the connection end of the coil in that side.
- 3 Place a leatheroid paper of length equal to the width of the core in the right side of the core. (Fig 3).

**To avoid insulation damage to the winding wires, check at intervals the position of the leatheroid paper which is kept on the core between the right coil side and the core**

- 4 Separate the inner coil from the group, hold the smaller coil in hand and keep the larger coil in front of the stator in a leatheroid paper tray. (Fig 3)

**TASK 8 : Connect the coil groups**

- 1 Connect the group connections of the same phase and solder them according to the end connection and developed diagrams (Fig 1 and 2 From Task 7). Sleeve the joints.
- 2 Connect the phase leads with the coil groups and insert the sleeve over the joints.

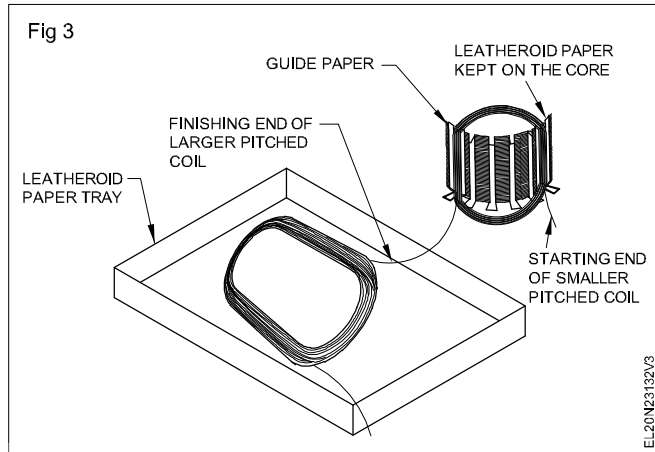

- 5 Insert the left coil side of the smaller coil in slot No. 2. (Fig 3)
- 6 Remove the guide papers and insert them in slot No. 7.
- 7 Insert the right coil side of the smaller coil in slot No. 7.
- 8 Remove the guide papers from slot No. 7 and insert them in slot No. 1.
- 9 Insert the left coil side of the larger coil in slot No. 1
- 10 Remove the guide papers and insert in slot No. 8 and then insert the right coil side of the larger coil in slot No. 8.

**See to it that the current direction in the group is correct according to the developed diagram.**

- 11 Insert the 2nd coil group having smaller and larger coils in slot No. 6, 11, 5 and 12 respectively.
- 12 Insert likewise 3rd, 4th, 5th and 6th coil groups in the respective slots. (Refer to the developed diagram)
- 13 Insert a separate paper in all the slots over the inserted coils.
- 14 Fold the slot liner and insert the wedge in all the slots.
- 15 Insert a half moon shaped insulation paper as phase insulator between the coils on either side of the overhang.

- 3 Use a nylon mallet and shape the overhang to the original size.

**Check the size of the overhang with the help of overhang template.**

- 4 Tie the hemp thread to bind the soldered joints along with the overhang.

### TASK 9 : Test the winding

- 1 Test the winding by megger continuity, short and insulation resistance test and note down results.  
(Task : 1, 2, 3 exercise 2.3.130)

### TASK 10 : Varnish the windings

- 1 Varnish the winding .
- 2 Dry the moisture by using lamp loads.
- 3 Check the varnish dry level.

### TASK 11: Test and assemble the motor

- 1 Test and run the motor to ascertain its performance.  
(Steps 18 to 31 exercise 3.1.33)

### TASK 12 : Calculate winding for the developed diagram

**For easy understanding of the steps a 24 slots, 24 coil, 4-pole, 3-phase motor is considered as an example. For the motor given as an example winding calculations are as under.**

$$1 \text{ No. of coils / phase} = \frac{\text{Total No. of coils}}{\text{No. of phases}} = \frac{24}{3}$$

= 8 coils/phase.

$$2 \text{ No. of coils / phase / pole} =$$

$$= \frac{\text{Total No. of coils}}{\text{No. of phases} \times \text{No. of poles}}$$

$$= \frac{24}{4 \times 3} = 2 \text{ coils / phase / pole.}$$

$$3 \text{ Pole pitch} = \frac{\text{No. of slots}}{\text{No. of poles}} = \frac{24}{4} = 6 \text{ slots / pole}$$

- 4 Coil pitch possible
- |   |                          |
|---|--------------------------|
| A | 5 (1 to 6) Short chorded |
| B | 6 (1 to 7) Full pitched  |

C 7 (1 to 8) Long chorded

$$5 \text{ Coil pitch selected} = 5 (1 \text{ to } 6)$$

$$6 \text{ Coil pitch selected is short chorded.}$$

$$7 \text{ Total Power degrees} = 180^\circ \times \text{No. of poles}$$

$$= 180^\circ \times 4 = 720^\circ$$

$$\text{Slot distance in degrees} = \frac{\text{Total electrical degrees}}{\text{No. of slots}}$$

$$= \frac{720}{24} = 30$$

$$9 \text{ Req'd. displacement between phase in terms of slots} =$$

$$\frac{120}{\text{Slot distance in degrees}}$$

$$= \frac{120}{30} = 4 \text{ slots}$$

### 10 Winding sequence

If 1st phase starts in the 1st slot.

2nd phase starts in the (1+4) i.e in 5th slot.

3rd phase starts in the (5+4) i.e in 9th slot.

### 11 Arrangement of coils

The coils are to be arranged in the slots in the sequence:

1-6, 2-7, 3-8, 4-9, 5-10, 6-11, 7-12, 8-13, 9-14, 10-15, 11-16, 12-17, 13-18, 14-19, 15-20, 16-21, 17-22, 18-23, 19-24, 20-1, 21-2, 22-3, 23-4, 24-5.

Fig 1 and 2 show the connection diagram and developed diagram for the above motor.

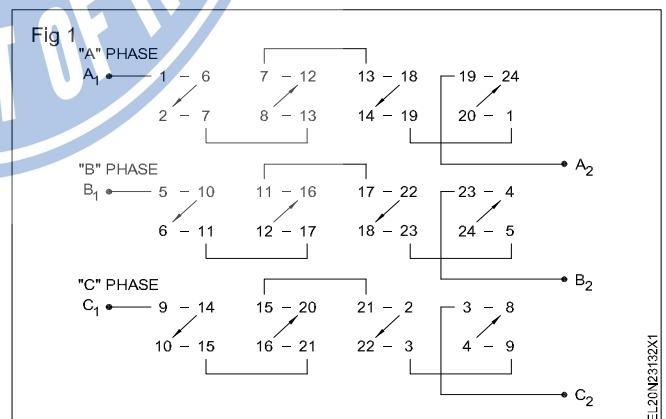

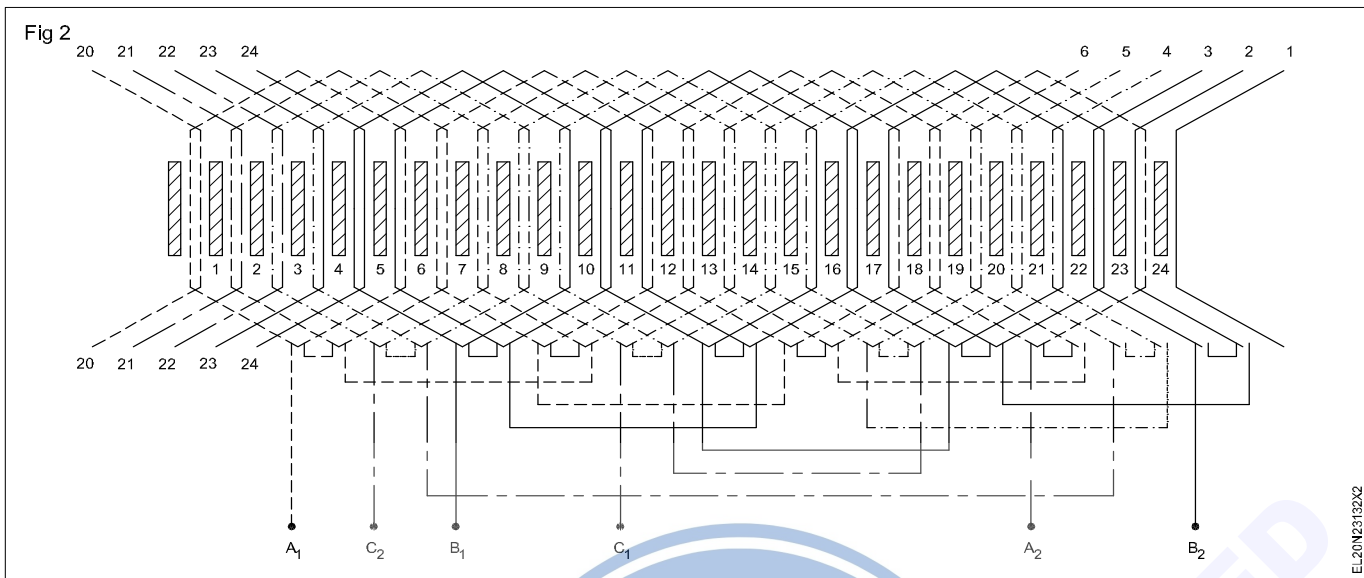

Table 12

**Data to be taken from the stator (before removing the coils)**

No. of slots ..... No. of coils ..... Coils per group .....

Group connectors ..... Wire insulation .....

Coil throw ..... Type of winding ..... Distribution/Concentric

Wedge material ..... Size ..... Binding material ..... Size .....

Overhang dimension Outer dia. .... mm Inner dia. .... mm

Length ..... mm Shape ..... (make template).

**Data to be taken (after removing the coils)**

Size of wire ..... mm No. of parallel wires ..... No. of turns .....

Size of coil length ..... mm (inside) width ..... mm (inside) Thickness ..... mm

Type of sleeve ..... size ..... Type of lead ..... size .....

1

2

3

Slot insulation ..... Type ..... Thickness ..... Dimension .....

Type of coil ..... Number of coils .....

Weight of single coil ..... Weight of the total winding .....

Front end bearing number ..... Rear end bearing number .....

Size of connection lead .....

Connection lead side with respect to terminal box .....

With the reference given in the winding calculations fill up the winding data for the motor given to you.

1 No. of coils / phase

= ..... coils/phase

2 No. of coils / phases / poles

$$= \frac{\text{Total No. of Coils}}{\text{No. of phases} \times \text{No. of poles}}$$

= ..... slots/poles

3 Pole pitch =  $\frac{\text{No. of slots}}{\text{No. of poles}}$  = ..... slots / poles

- 4 Coil pitch possible A) .....  
 B) .....  
 C) .....
- 5 Coil pitch as per the data collected is .....
- 6 Coil pitch selected is .....  
 (short chorded/full pitched/long chorded)
- 7 Total Power degrees =  $180^\circ \times \text{No. of poles}$   
 =  $180^\circ \times \dots = \dots$
- 8 Slot distance in degrees =  $\frac{\text{Total electrical degrees}}{\text{No. of slots}}$

- 9 Req'd. displacement between phases in terms of slots  
 =  $\frac{120}{\text{Slot distance in degrees}}$
- 10 Winding sequence  
 1st phase starts in the .....  
 2nd phase starts in the .....  
 3rd phase starts in the .....
- 11 Arrangement of coils  
 The coils are to be arranged in the sequence.

**Draw the connection diagram and the developed diagram for the motor given to you, on a separate paper.**

**TASK 13 : Prepare the stator to receive the winding**

- Set the core, if it is mangled (lightly tap with a nylon mallet to correct the core) and clean the slot to remove any old insulation paper.
- Select the insulation paper of the same grade and thickness or its equivalent as in the original and cut the insulation paper to the same size.

**Slot insulation paper must be approximately 10 to 15 mm longer than the slot length and is to be formed according to the shapes of the inner walls of the slot. The ends of the insulation are often cuffed to avoid the insulation paper from sliding off from its position.**



**TASK 14 : Prepare coils**

- Make a ganged former or select a readymade former according the old coil size. (Figs 1 and 2)

- Select the correct size of winding wire as per the data taken.
- Attach the former to the winding machine, wind the designated turns and make one set of ganged coils.
- Insert the ganged coils in the designated slots and check their correctness.

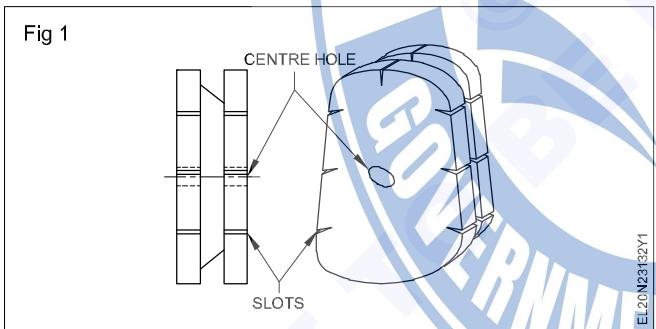

**While checking make sure that the coils are of the correct dimension so that the two coil sides could be accommodated as top and bottom coil sides in the same slot of the double layer winding, and the overhang dimensions are comparable to the template (as in the original).**

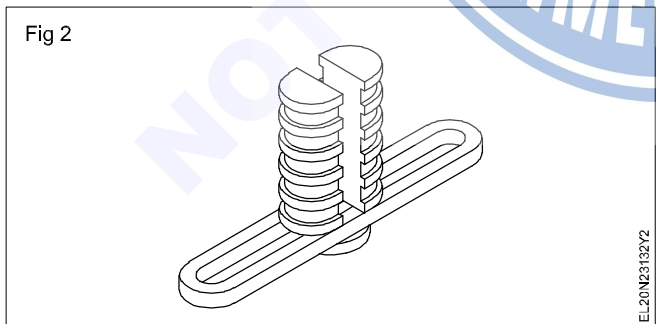

- Make necessary sets of ganged coils, if coil dimensions are correct

**In the example given, two coils are forming the gang. Choose the former according to the number of gang coils.**

### TASK 15 : Lay coils in double layer winding

Carefully examine the developed diagram in which the slot pitch is given as 1-6 and there will be two coils in a group. The left coil side of coil 1 is in slot 1 as bottom coil and the right coil side of coil 1 is in slot 6 as top coil. In double layer winding the coil sides should be placed in adjacent slots. Modify the procedure to suit the requirement of the given motor winding.

- 1 Insert the left coil sides of the first set of ganged coils in slots 1 and 2.
- 2 Leave the right coil sides of the ganged coils over the stator with a leatheroid insulation paper between the coil sides and core.

### TASK 16: Connect group leads - testing and varnishing

- 1 Bring out the group ends, connect, solder and insulate the groups. (Fig 1)

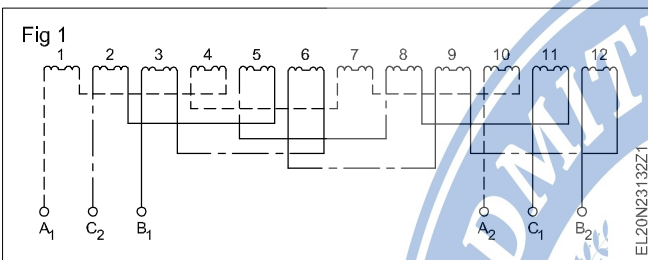

- 2 Connect the lead cables to the group connections and solder them.

- 3 Tie the hemp threads in the overhangs, to secure the sleeved joints and phase separator insulations.
- 4 Shape the overhangs and check with a template.
- 5 Test the winding for continuity and ground as per Exercise 3.3.138.
- 6 Assemble the motor if the test results are satisfactory and run it for ten minutes.
- 7 Dismantle the motor, impregnate the windings and dry them, if the results are O.K.
- 8 Assemble and test the motor on load.

**Maintain, service and troubleshoot the AC motor starter**

**Objectives:** At the end of this exercise you shall be able to

- identify the parts of the AC starters
- trace and draw the schematic diagram of the starters
- check volt coil, moving contactors, fixed contactors, NC and NO
- set the over load relay and timer.

Requirements	
<p><b>Tools/Instruments</b></p> <ul style="list-style-type: none"> <li>• Combination pliers 200 mm - 1 No.</li> <li>• Screw driver 200mm - 1 No.</li> <li>• Multimeter - 1 No.</li> <li>• Megger 500V - 1 No.</li> </ul> <p><b>Equipments/Machines</b></p> <ul style="list-style-type: none"> <li>• D.O.L Starter - 1 No.</li> <li>• Star Delta starter - 1 No.</li> <li>• Rotor resistance starter - 1 No.</li> <li>• Auto transformer starter - 1 No.</li> </ul>	<p><b>Materials</b></p> <ul style="list-style-type: none"> <li>• PVC insulated, stranded aluminium cable 2.5 sq. mm 650V grade - 25 m</li> <li>• Fuse wire 10 amps - as reqd.</li> <li>• Black insulation tape - as reqd.</li> <li>• ICDP switch 16A 500V - 1 No.</li> <li>• TPIC switch 16A - 500V - 1 No.</li> <li>• Push button station - 1 No.</li> <li>• Over load relay - 1 No.</li> <li>• Contactor - 1 No.</li> <li>• Time delay relay - 1 No.</li> </ul>

**PROCEDURE**

**TASK 1: Check and service AC motor starters**

1 Identify the parts of AC starters, like contactor unit, overload relay unit, start/stop push button unit, necessary fixing screws, hook up cables, starter base cover and timer. (Fig 1, 2, 3 & 4)

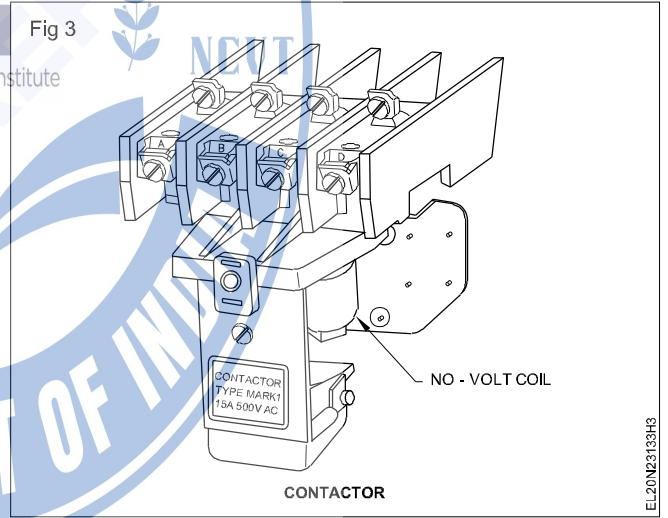
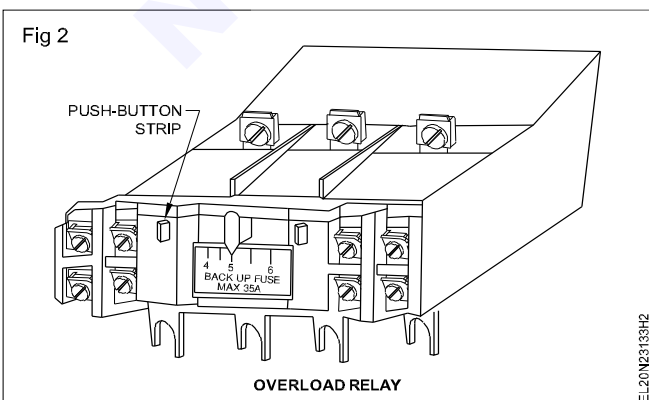
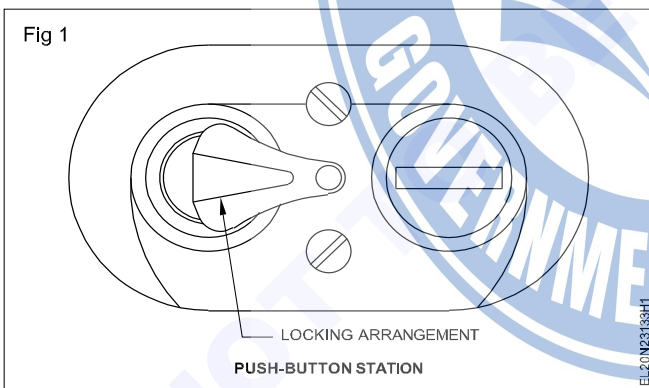

- 2 Investigate and check the contactors input and output terminals, auxiliary and main terminals, movable and fixed contacts, no volt coil, over load relay, their rating, normally closed relay contacts and their operation.
- 3 Identify the connecting terminals for inter connecting no volt coil, main supply to control circuit, normally open auxiliary contacts.
- 4 Draw the complete circuit diagram for D.O.L starter, star delta starter, rotor resistance starter and auto transformer starter. (Fig 5, 6, 7 & 8)
- 5 Get the diagram approved by the instructor.
- 6 Follow the trouble shoot chart -I.

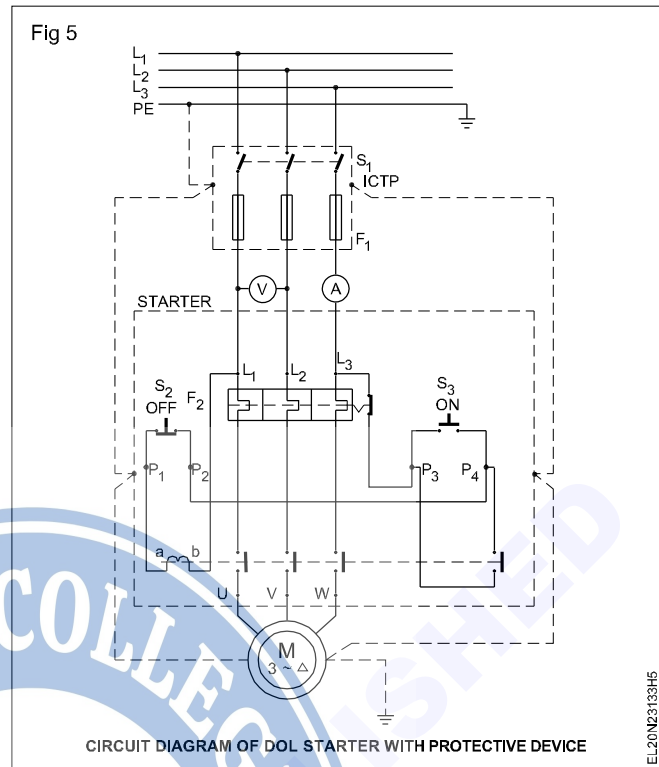
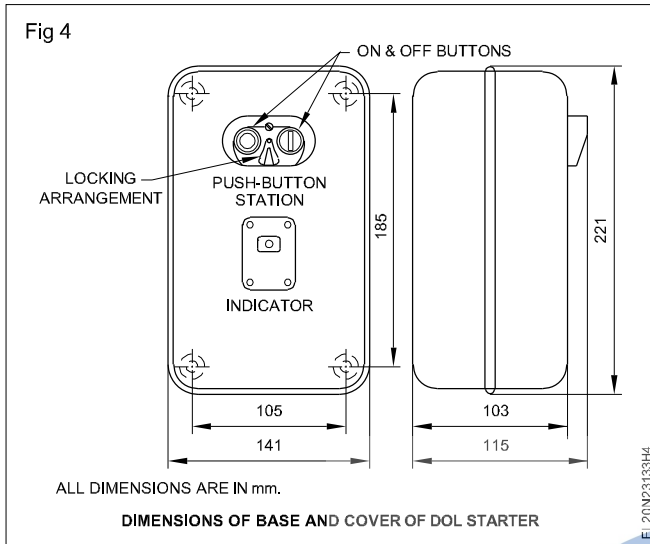

Do not tighten the screws more than necessary as too much tightening of screws will break the PVC casing of the contactor and OL relay.

A complete diagram showing the internal diagram of a starter of a particular make along with I.C.T.P and motor is given for your guidance. You can replace the internal diagram of the given starter in the place of the starter diagram shown in Fig 5.



Chart 1

NCVT Maintenance of DOL starters  
Industrial Training Institute

### I. Starter check chart

Trouble	Cause	Remedy
1 Contacts chatter	Low voltage, coil is not picking up properly, Broken pole shading ring. Poor contact between the pole. Faces of the magnet. Poor contact between fixed and movable contacts.	Correct the voltage condition. In case there is persistent low voltage. Replace Clean the pole faces. Clean contacts and adjust, if necessary.
2 Welding or overheating	Low voltage preventing magnet from sealing. Abnormal inrush current. Short circuit in the motor. Foreign matter preventing contacts from closing. Rapid inching.	Correct the voltage condition. In case of persistent low voltage coil. Check excessive load current or use larger contactor. Remove the fault and check to ensure that the fuse rating is correct. Clean contacts with suitable solvent. Install larger device or caution the operation not to operate the inch button too quickly.
3 Short life of contact points	Weak contact pressure	Adjust or replace contact springs.
4 Noisy magnets	Broken shading coil Magnet faces not mating Dirt or rust on magnet faces.	Replace magnet Align or replace magnet assembly. Clean with suitable solvents.

<b>Trouble</b>	<b>Cause</b>	<b>Remedy</b>
5 Failure to pick up	Low voltage  Coil open or short circuited. Mechanical obstruction in the moving parts.	Check system voltage, In case persistent low voltage, change to a lower voltage coil. Replace the coil. Clean and check for free movement of contact assembly.
6 Failure of moving mechanism to drop out.	Worn or rusted parts causing binding. Residual magnetism due to lack of air gap in magnet path. Gummy substance on pole faces causing binding.	Check wiring in the NVC coil circuit. Replace parts. Replace worn out magnet parts. or demagnetise the parts. Clean with suitable solvent.
7 Overheating of coil	Over-voltage Short circuited turns in coils caused by mechanical damage of corrosion High ambient temperature  Dirt or rust on pole faces increasing the air gap.	Check and correct terminal voltage. Replace coil.  Relocate starter in a more suitable area or use a fan. Clean pole faces.
<b>II Overload relays / release</b>		
1 Starter is tripping often.	Incorrect setting of over load relay Sustained overload	Reset properly. Check for faults/ excessive motor currents.
2 Failure to trip (causing motor burn out).	Wrong setting of O.L relay Mechanical binding due to dirt, corrosion etc	Check O.L relay ratings and set a proper relay, Clean or replace. Incorrect control wiring. Check the circuit and correct it.
<b>III Fuses</b>		
1 Constant blowing of fuses	Short circuit or poor insulation winding / wiring	Check the motor and the circuit for insulation resistance.
2 Fuse not blowing under short circuit condition.	Fuse rating too high	Replace with suitable fuse.
3 Fuse blowing off frequently.	Fuse rating too low. Overloading of feeder.	Replace with suitable fuse. Check for over-current, leakage and short circuit.