

Foundation bolts and types

Objectives : At the end of this lesson you shall be able to

- state the purpose of foundation bolts
- state the different types of foundation bolts and their uses
- designate the foundation bolts as per BIS
- mention the purpose of grouting
- name the different types of grouting.

Purpose of foundation bolts

For some machine tools, it is very essential to hold down the machines firmly on the foundation to prevent them from moving. For this purpose various types of foundation bolts or anchor bolts are used.

Types of foundation bolts

Foundation bolts are divided into two groups. They are:

- fixed type
- removable type.

Fixed type of bolts

Fig 1 shows the ordinary foundation bolt with mild steel plate. The rag bolt shown in Fig 2 is usually forged and filled up with lead or cement. A simple form, shown in Fig 3, is known as eye foundation bolt. A bent type of bolt is shown in Fig 4.

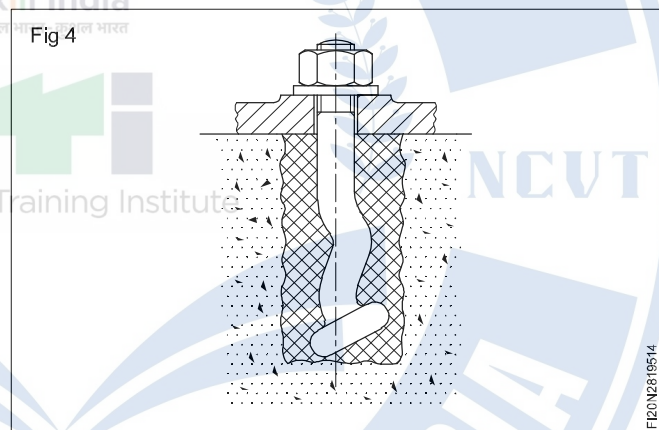
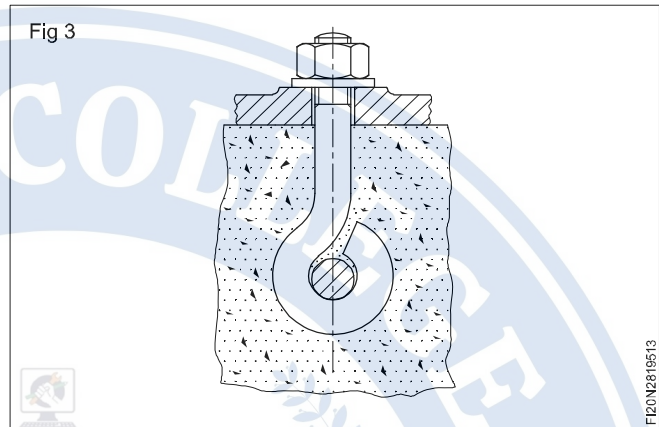
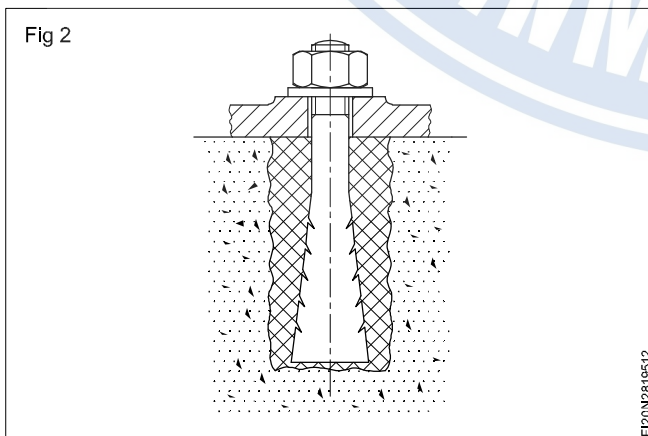
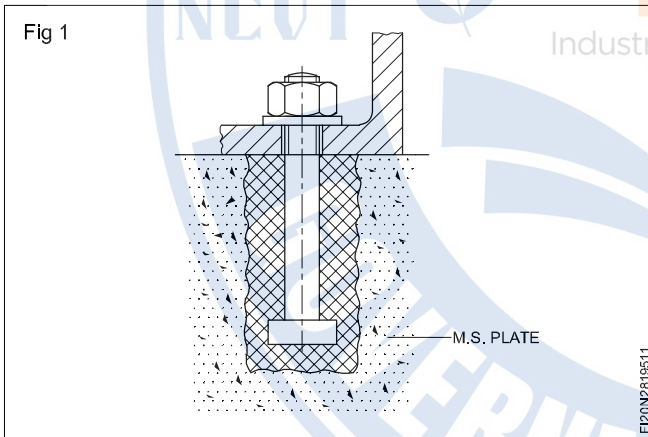
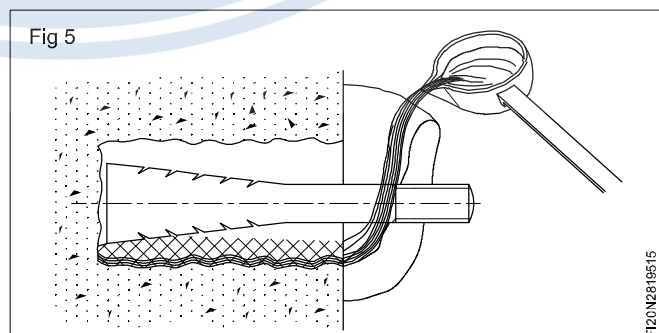
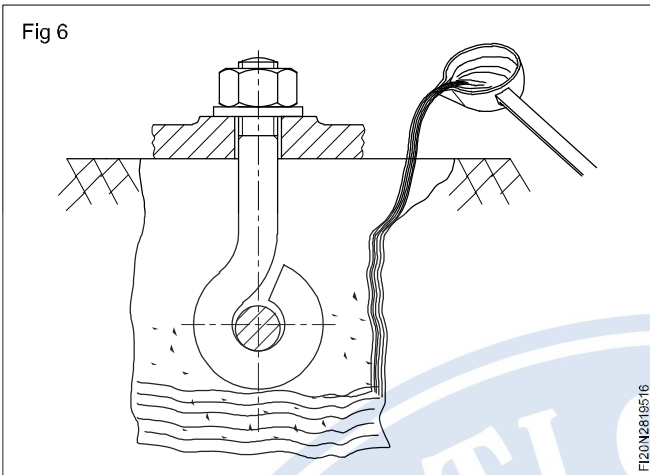

Fig 5 shows running up bolts in a horizontal position. A clay cap is formed around the bolt to support this and direct the lead into the hole. After running up, the lead should be caulked in position to consolidate this.

When running with lead, care should be taken to see that no water is collected in the hole; otherwise steam will be rapidly generated which will blow the lead out, which may cause serious burns.



As an alternative to lead, where quick setting is required, rock sulphur can be melted down in an old kettle or ladle and run into the bolt hole as quickly as possible. (Fig 6)



Removable type (Fig 7)

For large machines a long cotter bolt is commonly used. This bolt is provided with a square foundation plate and a removable cotter at the bottom. In forming the foundation, pockets are left in the sides of the bolt holes which are then capable of being replaced at any time, if necessary.

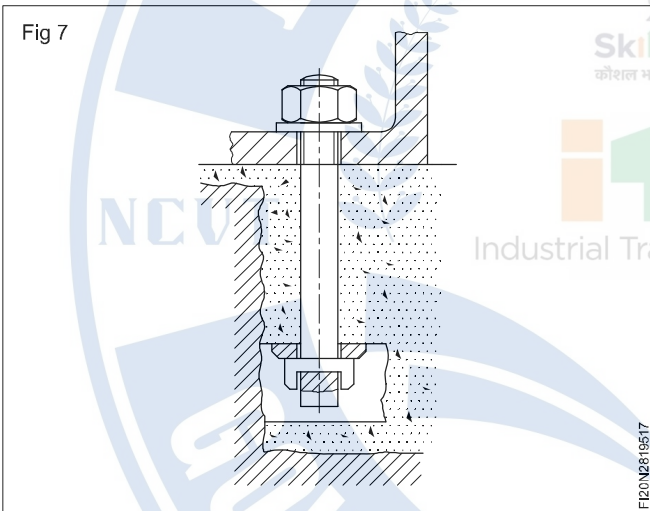

The rawl bolt (Fig 8)

In this type four clamps are flexibly mounted on the bolt which expand by wedge action when tightened up. The advantage is that they can be removed and used again, if necessary.

Expanding conical washer foundation bolt (Fig 9)

This consists of a bolt on which are threaded conical washers and ferrule. On drawing up the bolt, the washers are flattened which grip the inside of the hole by expansion.

Grouting

After levelling the machines in the aligned condition with the foundation bolts and wedges, there will be a gap left over between the bottom of the machine and the top of the floor or foundation block. This space is filled up with grouting materials such as cement concrete or sulphur or lead and the process is known as 'grouting'.

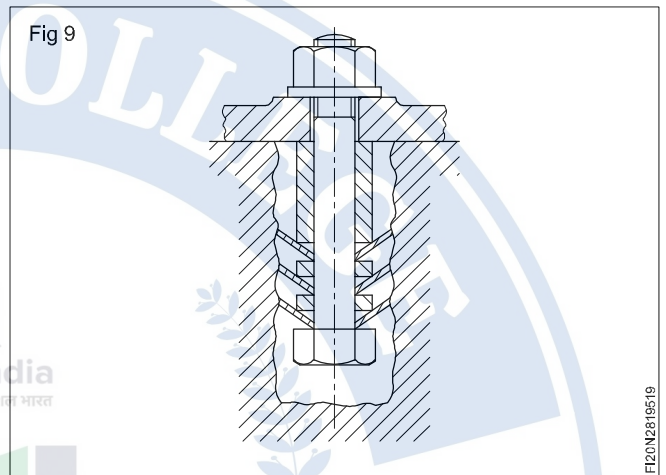
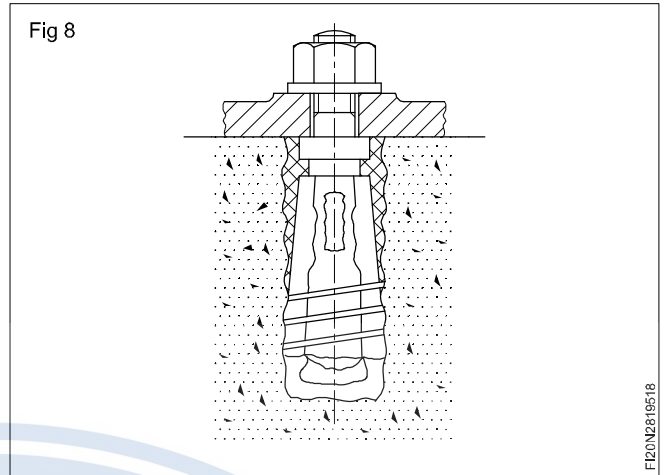

When 'mould' boxes are used and the anchor or foundation bolts are suspended in their respective pockets, the pockets are filled up with the grouting material.

Purpose

- To ensure that the machine rests firmly on the top of the foundation block or the floor.
- To prevent lateral shifting particularly for the machines like shaper, planer, surface grinder etc. which are having reciprocating motion.

Types of grouting

Cement concrete grout (Fig 10)

It is a most common grouting process wherein cement concrete mixture is used. This mixture can bear the compressive load of the machine. This is quite cheap and strong to withstand the displacement of the machine. This is not suitable for oil-soaked areas.

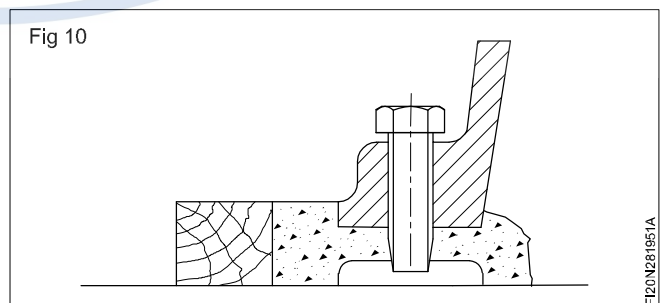

Sulphur grouting

Since sulphur remains unaffected by oil or grease it is recommended as grouting material for oil-soaked areas.

Lead grout

Lead is mainly used as a grouting material for steam turbines. It is too expensive to be used for general machine foundation.

Moving equipment with crowbars

Objectives : At the end of this lesson you shall be able to

- name the different types of crowbars
- state the uses of crowbars
- state the methods of lifting and moving machines with crowbars and rollers.

Crowbars give leverage, so that heavy loads can be lifted or moved. They are made in different lengths with hexagonal or octagonal steel bars. Short crowbars are easier to handle and the point will fit into a narrow gap, but requires more force. Long crowbars provide a greater leverage.

Types of crowbars (Fig 1)

There are two types of crowbars, single or double ended. A single ended crowbar is safer to use as the handle has a rounded end. The double ended crowbar normally has a curved end used for lifting, and a straight end used for pushing.

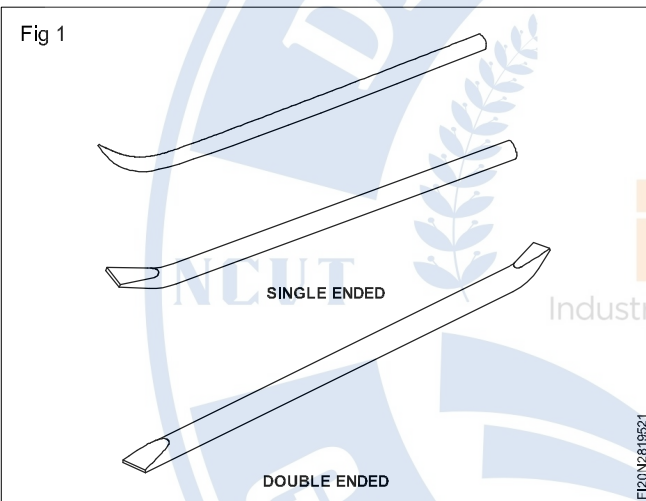

Lifting equipment by crowbars

If the gap under the machine is not good enough to accept the tip of the crowbar, tap a small steel wedge under the machine to increase the gap and place the toe of the crowbar under the machine and press the other end down to lift the machine. (Figs 2 & 3)

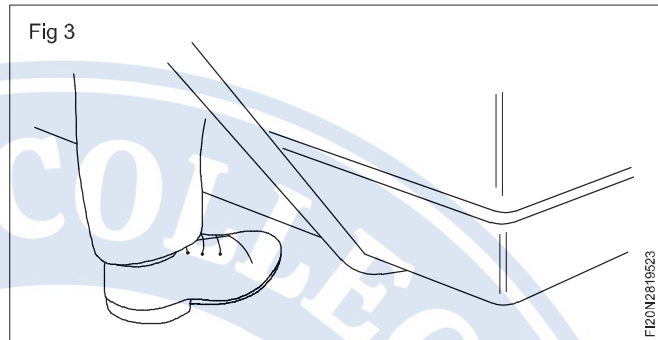
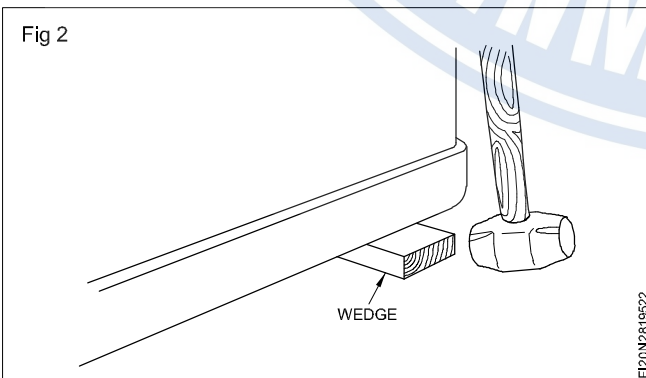

Position the handle so that no one will be endangered if the crowbar slips. When pushing or lifting, never push the crow bar close to the load or to the ground, as your fingers might be caught if the bar slips.

Always use both hands and hold close to the end of the crowbar to get maximum leverage. (Fig 4)

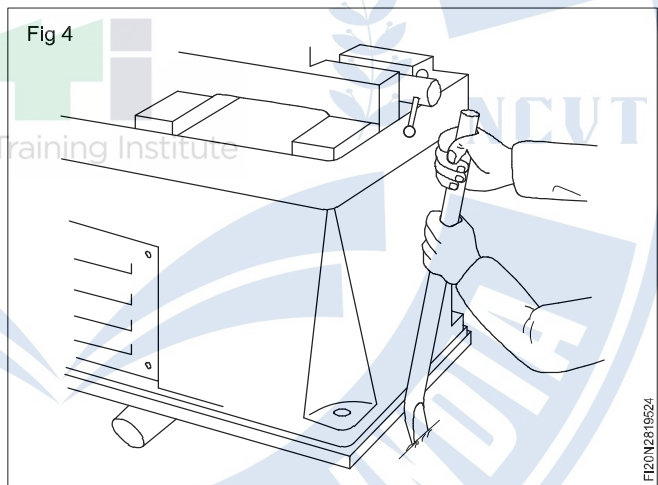

Stand with the legs apart so that the balance is not lost if the crowbar slips. (Fig 5)

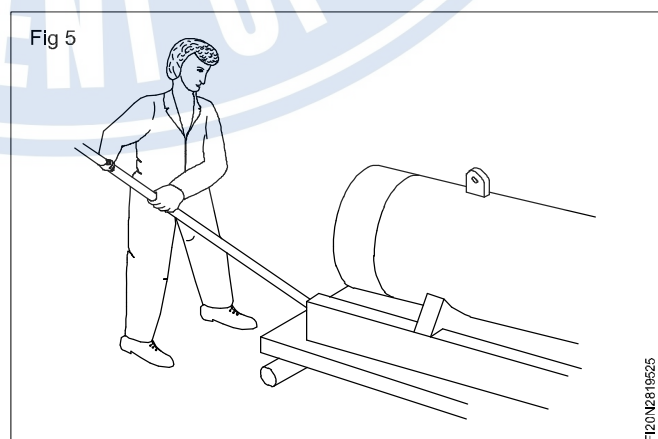

Equipments are provided usually with a lifting pocket. Place the toe of the crowbar in it for lifting the machine and moving it. (Fig 6)

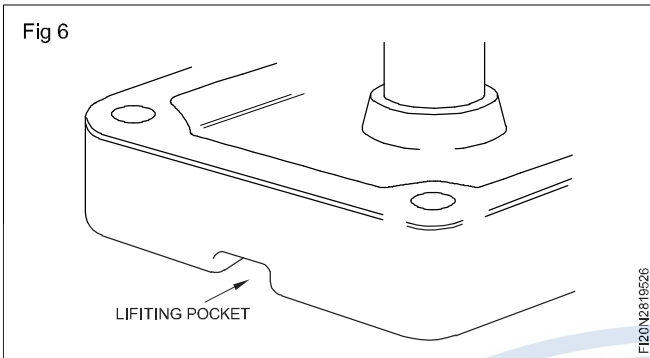

The fulcrum point must be firm enough to take the force. If the point of the crowbar is used as the fulcrum, it must be dug in firmly to prevent slipping. (Fig 7)

Check the condition of the crowbar, and if found bent or cracked, it must not be used. The burrs or sharp edges on the crowbar must be removed before using it.

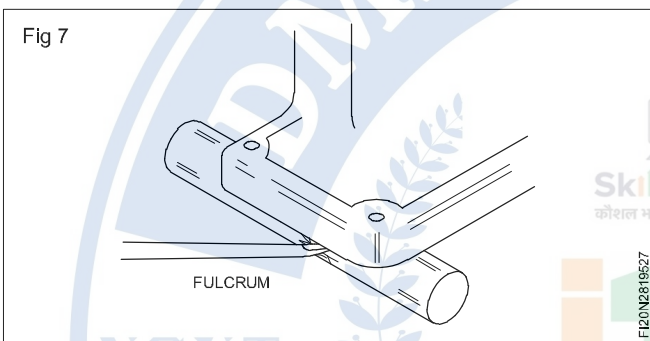

Rollers

Rollers are placed under the equipment so that they can be moved easily. Mild steel or G.I pipes of sufficient wall thickness can be used as rollers. The rollers should be long enough to project from both sides of the load so that they can be positioned easily. The diameter must be large enough to roll over any unevenness along the route but small enough so that they can be lifted easily. (Fig 8)

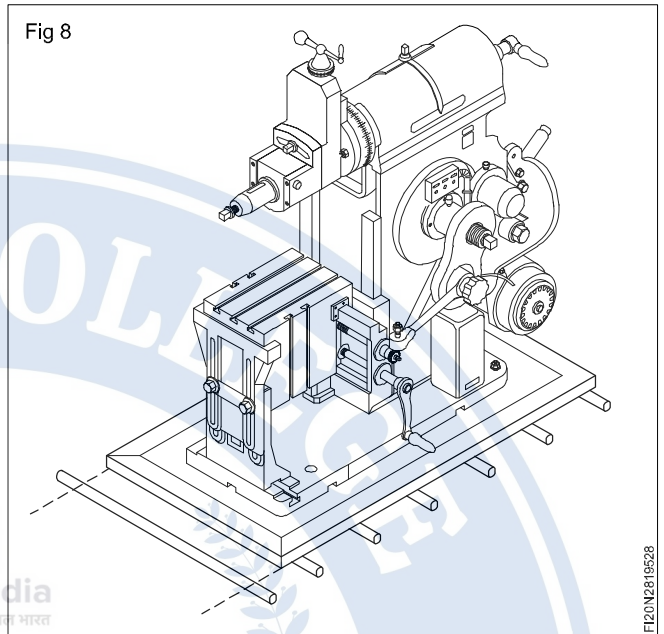

Moving equipment using rollers

Before starting to move a load, check the route and remove any obstructions. The route should be flat and firm enough to take the weight of the moving equipment.

Precision spirit level

Objectives : At the end of this lesson you shall be able to

- state the construction of a spirit level
- state the importance of a precision spirit level
- define the sensitivity of a precision spirit level
- state the relationship between vial radius and the sensitivity of a spirit level
- state the causes of errors in spirit level.

Levelling of the machine is a very important operation before proceeding to conduct geometrical tests. A precision spirit level is used to level the machine tools accurately.

Spirit level

It consists of a curved glass tube called 'VIAL' containing industrial alcohol 'spirit' and a bubble of 'AIR' trapped in the tube. The spirit and the bubble are both acted upon equally by the force of gravity. (Fig 1)

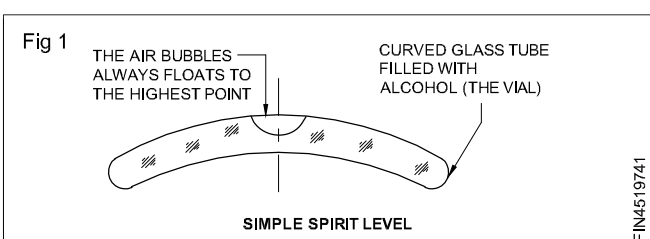

Since the spirit has a higher density, it is pulled down to the bottom of the tube and the bubble always floats to the top.

The vial is set in a cast iron base and adjusted such that the bubble rests at the centre of a scale (Fig 2) when the base is horizontal.

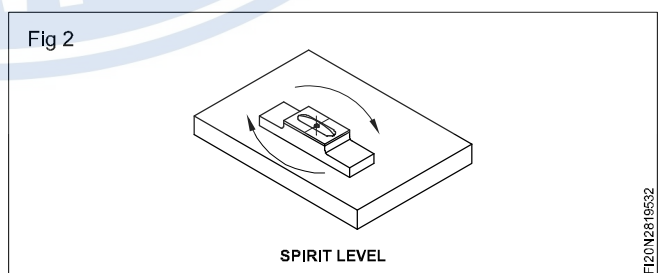

Precision spirit level (Fig 3)

Spirit levels used for high precision measurements should

have a sensitivity of about 0.02 to 0.05 millimetre per 1000 millimetres for each division.

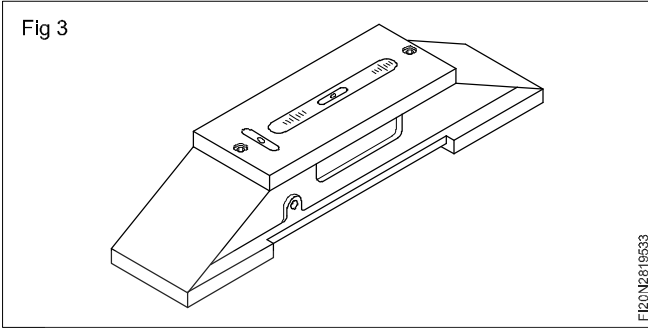

If the movement of the bubble by one division corresponding to a change in slope of 6 to 12 seconds of a level of 0.04mm per 1000mm is chosen, then

$$1 \text{ division} = 0.04 \text{ mm}/1000 \text{ mm}$$

$$3/4 \text{ division} = 0.03 \text{ mm}/1000 \text{ mm}$$

$$1/2 \text{ division} = 0.02 \text{ mm}/1000 \text{ mm}$$

$$1/4 \text{ division} = 0.01 \text{ mm}/1000 \text{ mm}.$$

It is quite easy to estimate within a quarter of a division.

Hints on spirit level

Spirit levels which are too sensitive are difficult to bring to rest in a workshop in which machines are running. Levels with low sensitivity result in insufficient reading accuracy, as very small fractions of a division have to be estimated.

The bearing surfaces of spirit levels should be as long as possible. For testing medium size machines the level should not be less than 200mm long. It is often advisable to use a bridge piece (Fig 4) the feet of which are about 300 mm apart. The spirit level can then be placed on the scraped surface of the bridge. This method avoids errors which could be caused by irregular scraping of the surface to be measured.

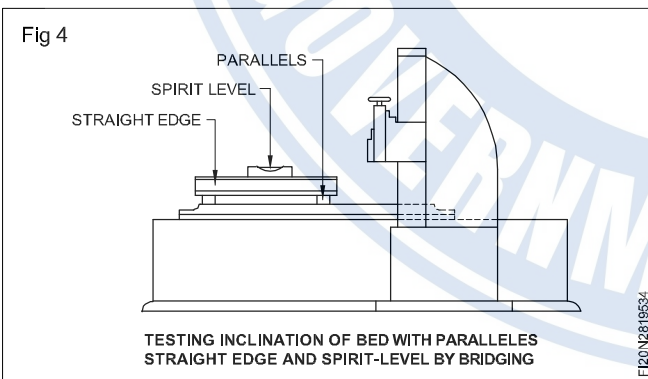

Sensitivity of spirit level

The sensitivity E of the spirit level is the movement of the bubble in millimetres which corresponds to a change in slope of 1 millimetre per 1000 millimetres.

$$E = \frac{\text{Movement of bubble in mm}}{1 \text{ milli metre per metre}}$$

The inside of the glass tube of a spirit level has a shape of a circular arc of radius R which moves during a change of slope around the centre M of its curvature. (Fig 5)

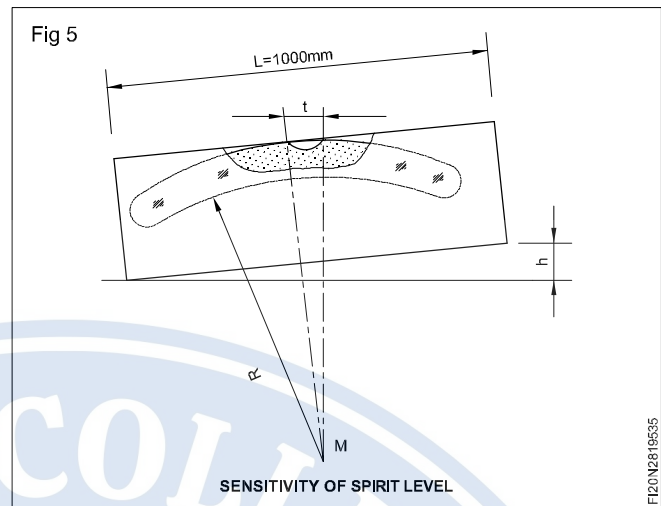

If the slope is measured as a ratio of h/L, and the movement of the bubble is t then

$$t/h = h/L \text{ and}$$

$$R = \frac{t}{h/L}$$

$$\text{Since } E = \frac{t}{h/L}$$

$$R = E.$$

Radius and sensitivity

The sensitivity of the spirit level is equal to the radius of curvature of the barrel shaped bubble tube. Therefore the sensitivity of the level depends only on the radius of the curvature of the bubble tube and not on the length of its bearing surface.

Causes for errors in spirit level reading

- Wrong position of the vial in the housing
- Faulty graduation
- The surface finish of the piece to be tested
- The influence of temperature
- Personal errors of the inspector

Reading spirit levels depends on:

- the quality and length of the bearing surface of the workpiece
- dimensional stability of the metal housing.

Ropes

Objectives : At the end of this lesson you shall be able to

- name the different types of ropes and their uses
- state the precautions to be observed while using ropes
- state the general inspection points for using ropes.

Ropes are made from individual fibres, spun together like string or yarn. Hemp, cotton, Manila, steel and synthetic wire are used in the manufacture of rope. Manila and hemp ropes are manufactured from the fibre of wild banana plants.

Ropes are manufactured in three or four strands. Manila and hemp ropes are used for light duty hoisting with a rope pulley block.

The following precautions should be observed while using the ropes.

- Avoid running the rope over sharp edges.
- Ropes should be kept dry because moisture hastens their decay.
- Hang wet rope loosely in an area where it can dry before it is used.
- Avoid dragging of rope over concrete, gravel and other rough surfaces.
- Frozen rope should not be used until it is thawed.

Wire ropes

Wire ropes or cables are built up of strands of wire laid together in the direction of opposite twists which form the rope. Standard wire rope is made from strands encompassing a single core.

Wire ropes are used for heavy duty hoisting

When the wires and strands are twisted in the same direction the rope is known as 'Lang lay rope' (Fig 1) and when twisted in the opposite direction it is known as regular lay rope. (Fig 2) The combined lay rope is shown in Fig 3.

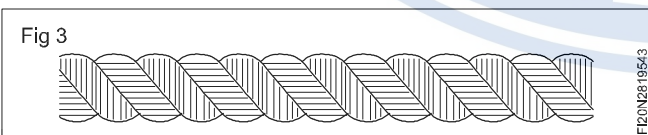
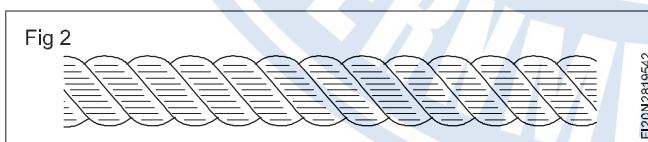
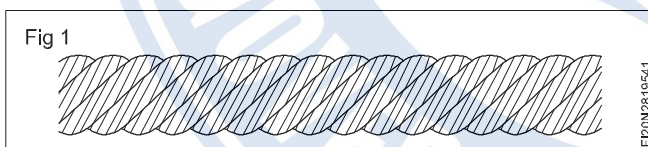

Rope inspection

- Inspect ropes frequently for damage.
- Surface inspection will reveal broken or worn out strands.
- For interior inspection twist the rope in the opposite direction to the way it was spun.

This will open up and separate the strands so that the interior fibres can be examined.

Wooden block

The position of the foundation is first determined, marked off and wooden pegs are driven if it is in the soil. (Fig 4)

The size of excavation is drawn with chalk if it is on a concrete floor.

Excavating the hole should be done as neatly as possible but should the soil persist in falling into the hole it may be advisable to shore this up by the use of shuttering. The excavation should be made a few millimetres deeper than the required foundation depth. The bottom surface is well rammed prior to and after placing a layer of clean bottoming stones or broken bricks.

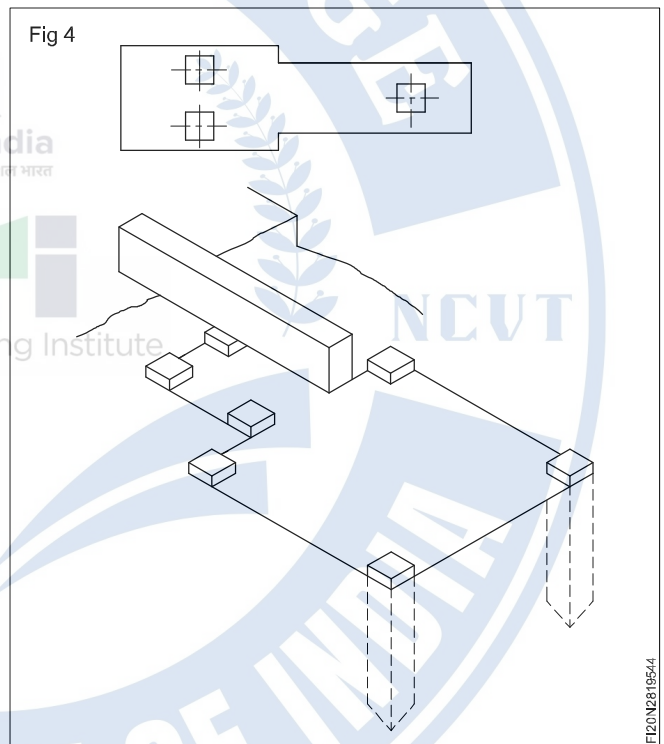

Wooden template

A wooden template is formed as shown in Fig 2 to represent the base of the machine and to support bolts over the excavation as shown. The combined thickness of the template frame A and blocks B should equal the thickness of the foot of the machine as shown. These boxes are formed of light timber and are suitably nailed for easy removal later.

Wooden forms

Wooden forms for concrete foundations are made and placed over the excavation.

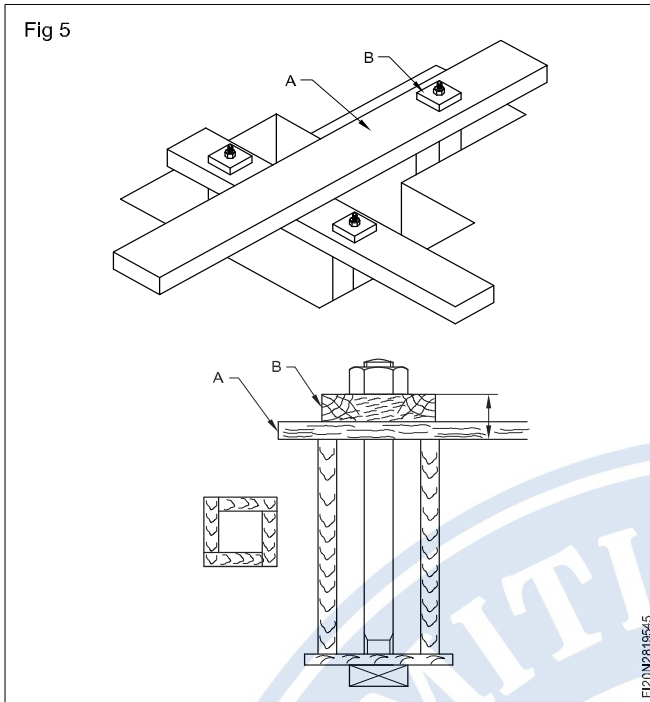

Bracing the wooden form

After placing the wooden form in position in the excavation, it is firmly braced from the outside so as to withstand the pressure of the concrete and prevent any movement when the concrete is being poured.

Concrete

Should be prepared from clean cement on a wooden surface. Proportions for the mixture vary. A good average mixture is 1:2:4. ie 1 part cement, 2 parts sand and 4 parts stone. This is mixed thrice when dry and thrice after wetting and is immediately placed on the excavated area after a good spraying with water on the excavated area.

The foundation should be given a day atleast to set before the template is removed.

Pulley block

Objectives : At the end of this lesson you shall be able to

- describe of pulley block
- use of pulley block.



Skill India
कौशल भारत-कुशल भारत

Pulley block (Fig 1)

Pulley block is a system of two or more pulleys with a rope or cable threaded between them, usually used to lift heavy loads. The pulleys are assembled together to form blocks and then blocks are paired so that one is fixed and one moves with the load. The rope is threaded through the pulleys to provide mechanical advantage that amplifies the force applied to the rope.

A block is a set of pulleys or "Sheaves" mounted on a single frame. An assembly of blocks with a rope threaded through the pulleys is called tackle. A block and tackle system amplifies the tension force in the rope to lift heavy loads. They are common on boats and sailing ships, where tasks are often performed manually.

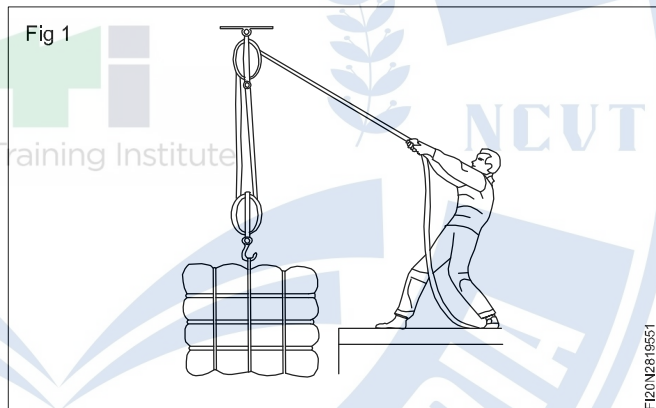

Plumb bob

Objectives : At the end of this lesson you shall be able to

- state the construction of plumb bob
- state the use of plumb bob.

The plumb bob (Fig 1)

The plumb bob employs the law of gravity to establish. A string, suspended with a weight at the bottom will be both vertical and perpendicular to any level plane through which it passes. In a sense, the plumb bob is the vertical of the line level.

The plumb consists of a specially designed weight and coarse string made of twisted cotton or nylon threads. At end of the string weight is affixed. Precisely machined and balanced bobs have point tips and can be made of brass, steel or other materials

How to use a plumb bob

To use the plumb bob, the string is fixed at the point to be plumbed. The weight, or bob, is then allowed, to swing freely, when it stops, the point of the bob is precisely below the point at which the string is fixed above.

Fig 1

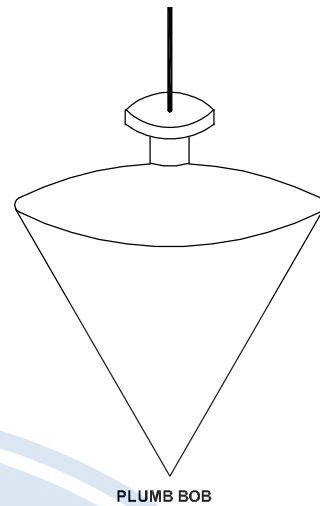

FI20N2819561

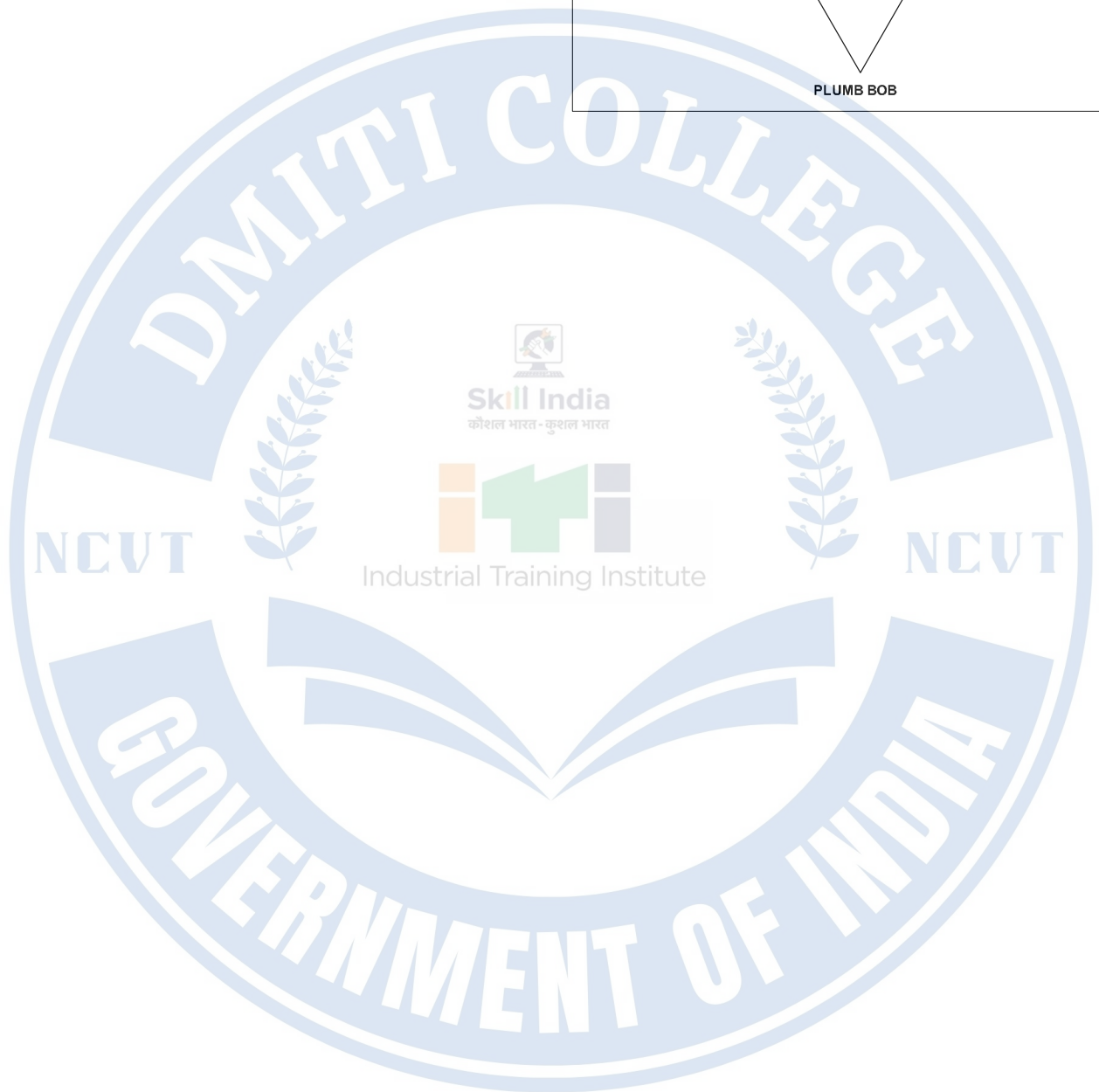

Sling load for shifting

Objectives: At the end of this lesson you shall be able to

- state different type of slinging arrangement
- state the common types of chain sling
- mention different types of fastening bolts, hooks, lifting clamps etc.
- illustrate various method of slinging practice
- define rigging and various rigs and fittings.

Slinging is an important skill in lifting and shifting load in industrial practices.

Slings are made with fibre rope, (manila, sisal, nylon, terylene and polypropylene) chain, wire rope etc. Other appliances like hooks, eye bolts, shackles, lifting clamps etc are used to make or sling considering the type of the load.

Chain sling

Chain links are fabricated by welding from carbon or alloyed steel. Links are formed to the shape and welded together to form a chain.

Chain slings are of different types, namely

- Single leg chain (Fig 1)

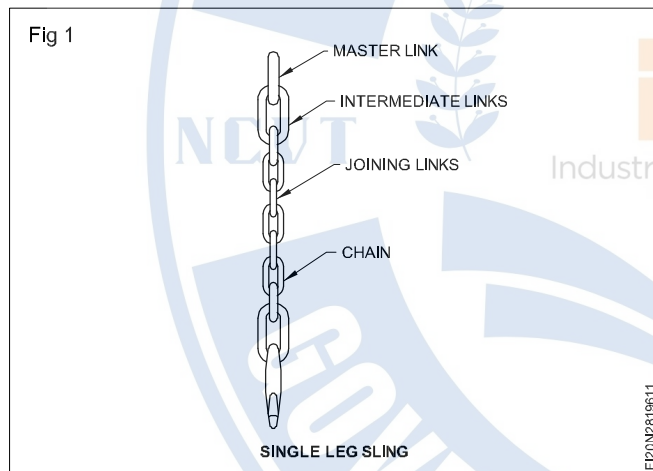

- Double leg chain (Fig 2)
- Four leg chain (Fig 3)
- Endless chain (Fig 4)

A chain will have the following components (Fig 1)

- Master link.
- Intermediate link.
- Joining link.
- Chain hook.

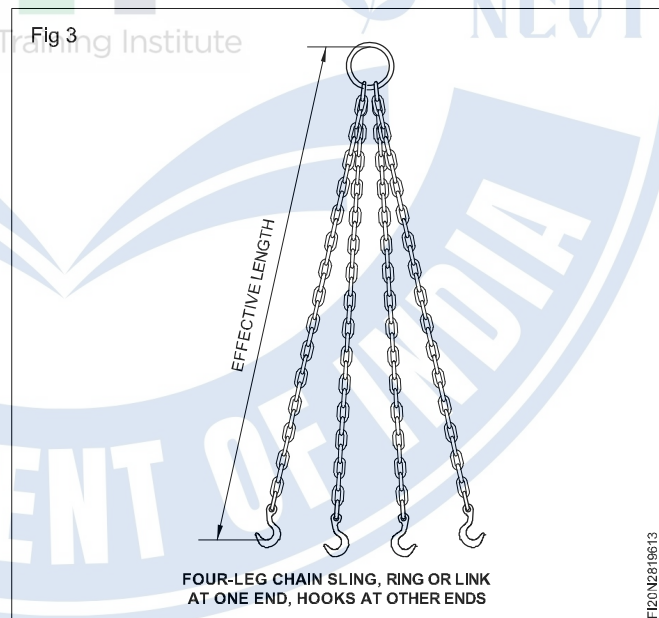
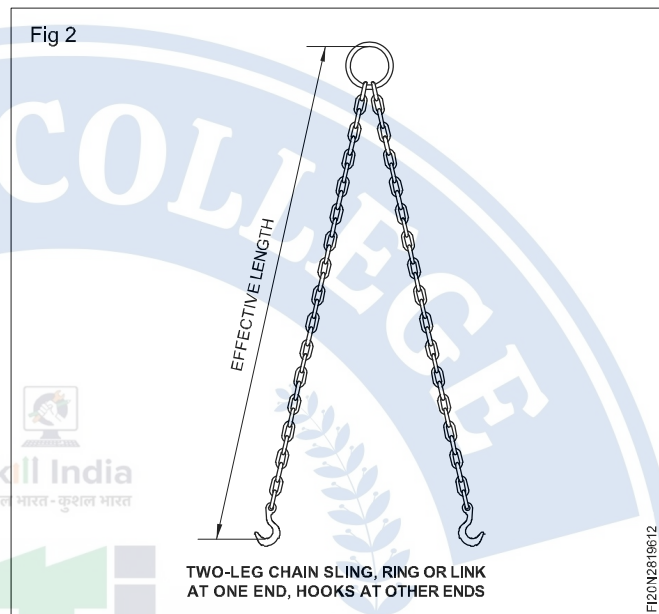

Wire rope sling

Wire rope slings are made of steel wire rope to form eye thimble mechanically spliced which accommodates a master ring on one side and or plain eye look is known as single legged sling (Fig 5a). Similarly, two legged, three legged and four legged slings are shown in (Fig 5b, c and d) respectively.

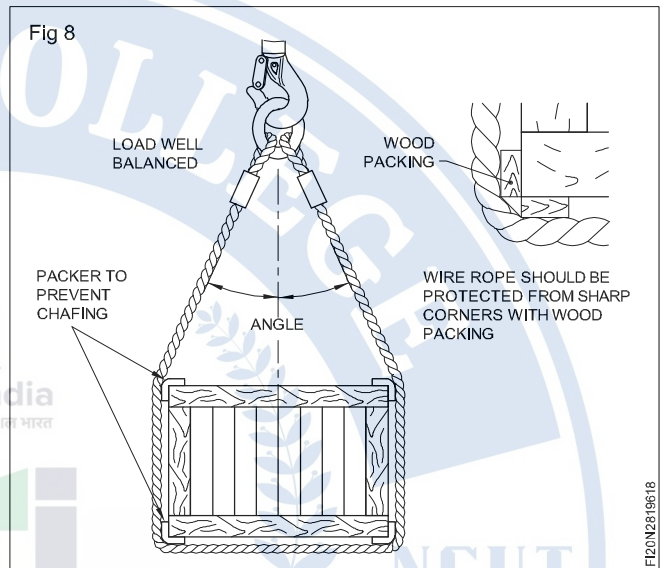
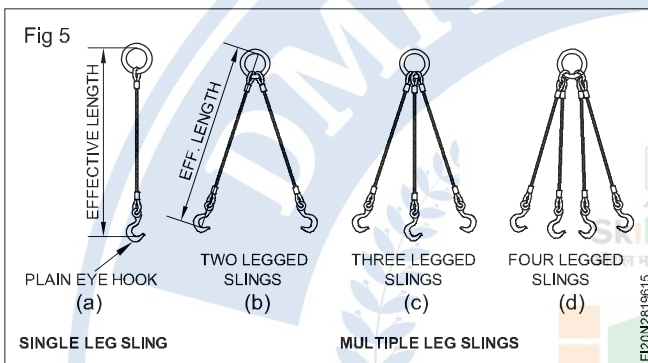
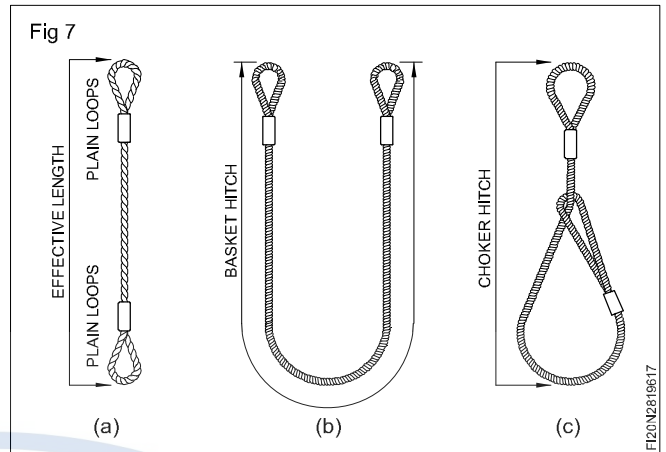
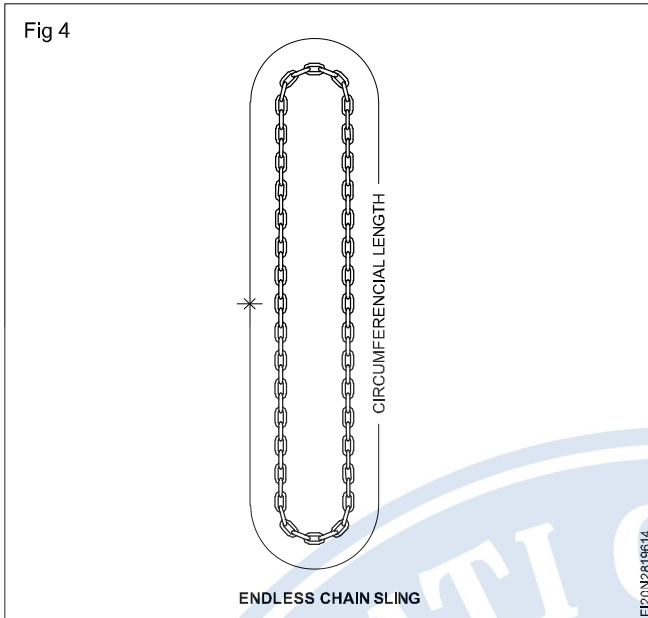

A few other slings like sling with safety swivel hook, Dee shackle and plate lifting clamp with effective length are shown in Fig (6a, b and c) respectively.

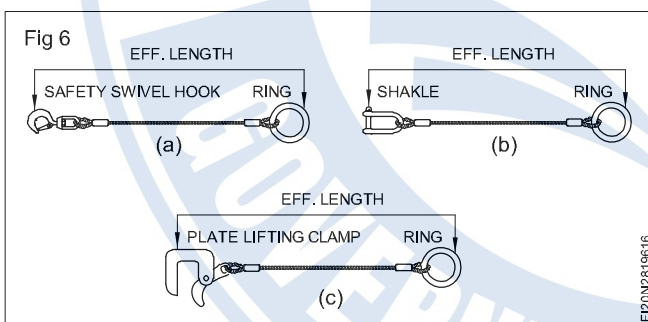

Some other types of single part rope slings include plain loop on both ends (Fig 7a), basket hitch (Fig 7b) and choker hitch (Fig 7c) are shown.

The following points are to be noticed and followed strictly.

- Fibre rope sling should be used only for lifting and shifting lighter loads.
- In case of sharp edges use soft pads (packer, wooden blocks) Fig.8 to protect the sling and the edges of the load as well.
- Check the condition of the sling and consider the load carrying capacity of the sling.

- Fibre rope get spoiled due to heat and in presence of toxic liquid and fumes. However, polypropylene ropes offer goods resistance to water chemicals and alkalis. They are stronger, reliable and durable comparing to other fibre ropes.
- Always prepare the sling to keep the load in well balanced condition.
- Prepare a sling for the load within permissible angle as in Fig.9 (30° - 90° , 120°). Lesser the angle load carrying capacity of the slings is more. When the angle exceeds 120° , the load carrying capacity of the sling is reduced to half.

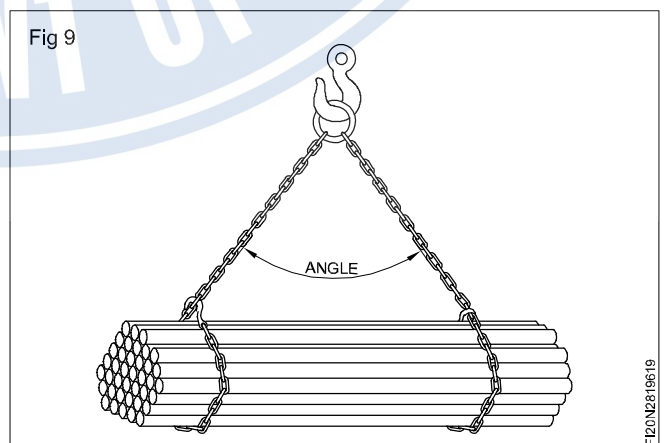

- Ensure about the safe working load (SWL) of the chain and wire rope slings.
- Chains should not be twisted for slinging.
- Avoid formation of loop in wire rope slings which will lead to damage.
- Avoid riding on the load.
- Use guide rope for lengthy article being handled by a single crane.
- Avoid putting a sling round a radius of less than three times the rope diameter.
- Sling cylindrical object with wire rope wherein bight angle should not exceed 120° . (Fig 10)

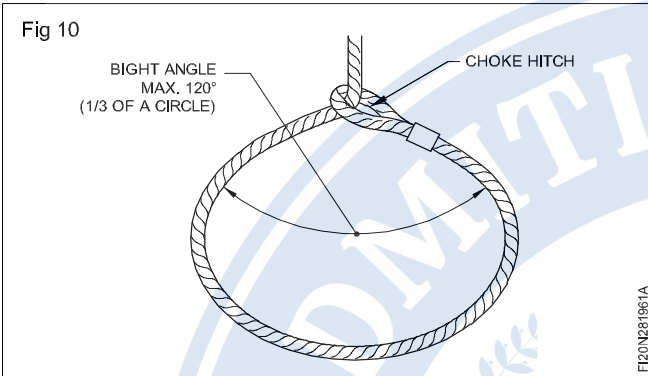

- Always keep yourself away from the suspended load.
- After completion of the work always return the hook fasten to the master ring.

Shackles

These are used for holding rings, eyes and hook which allow slings to adjust themselves easily to prevent bends, kinks etc in wire ropes. They are often used to join together the ends of slings. Bow shackle and Dee shackle are shown in (Fig 11a and b). Dynamo eye bolt (Fig 12a), Eye bolt with link (Fig 12b). These are used commonly to lift vertical load such as dynamo and other loads, provided with screwed holes to fit eye bolt.

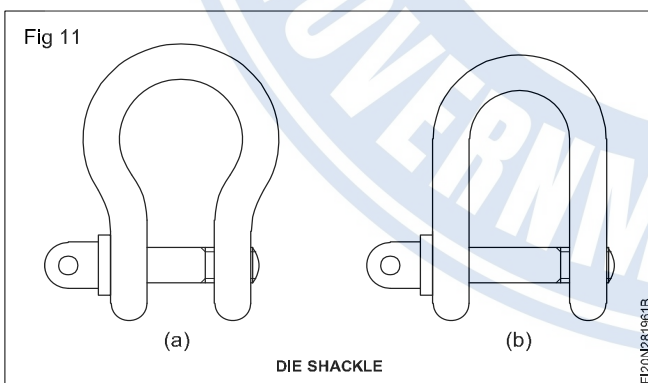

Slinging hook

Hooks are used in chain and wire rope for anchoring load. A few common types are shown in (Fig 13a,b,c,d,e). These hooks are made of high Tensile steel and drop forged to the shape. Eye hook (Fig 13a) is commonly used for handling load by the crane. Bureau of Indian Standard has recommended in eye hook with safety catch (Fig 13b)

for general handling purposes. Swivel spring safety hook (Fig 13c) is capable of turning around and adjust itself to prevent twisting. Barrel hook (Fig 13d) is used for handling barrel. Chain clutch hook (Fig 13e) can be used for fastening to any portion of the chain after wrapping around the load. Cargo hook (Fig 14a) is used for handling general cargo in port. Ramshorn hook (Fig 14b) is used in heavy duty crane to fasten the sling from both sides of the hook. Joist or girder hook (Fig 14c) is used for handling joists or girders.

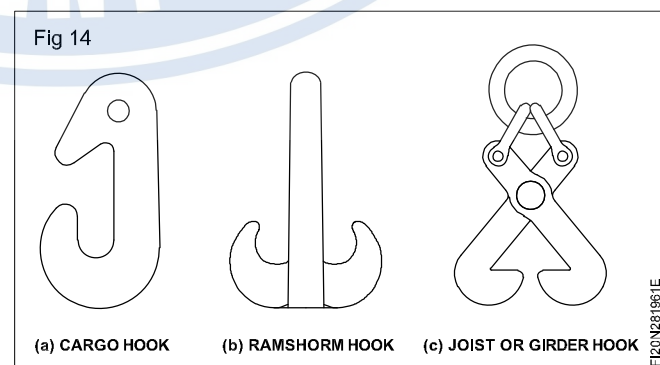
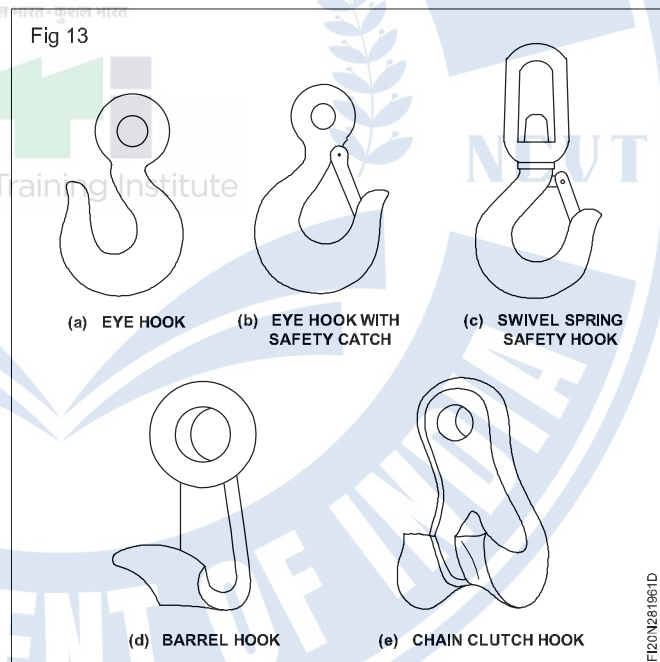
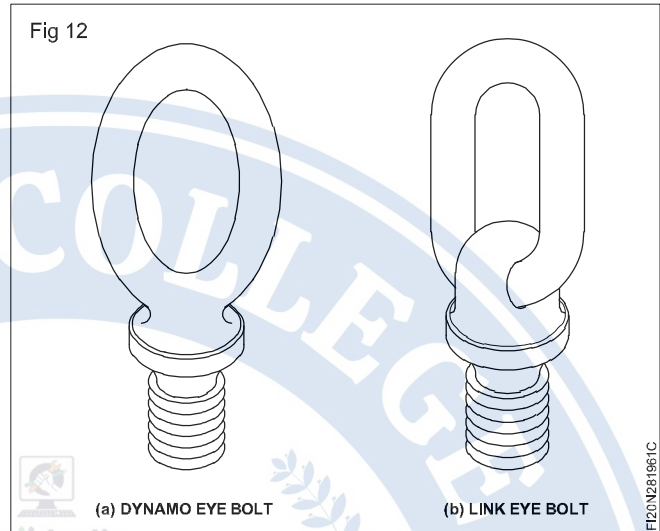

Lifting clamps

Lifting clamps are of various designs to suit the application. Vertical and horizontal plate lifting clamps as shown in (Fig 15a and b) respectively are used for lifting plates vertically and horizontally. As the tension is applied to the rope or chain, the jaws grip the plate tightly for effective lifting.

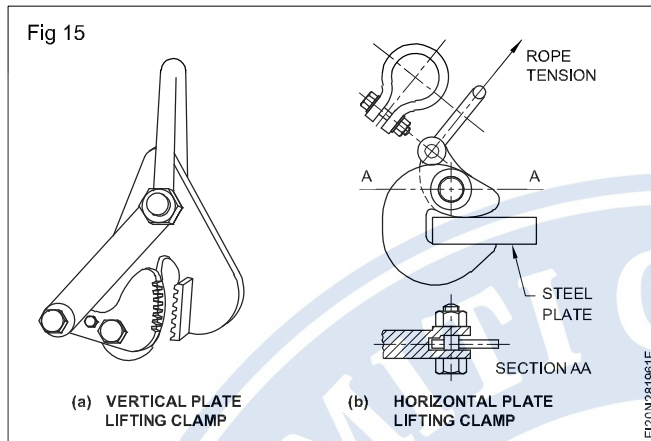

Tensioning screws

These screws or bolts are used in a situation where adjustment in tension is essential.

Common types

- 1 Union bolt (Fig 16a)
- 2 Straining screw (Fig 16b)
- 3 Rigging screw (Fig 16c)
- 4 Turn buckle (Fig 16d)

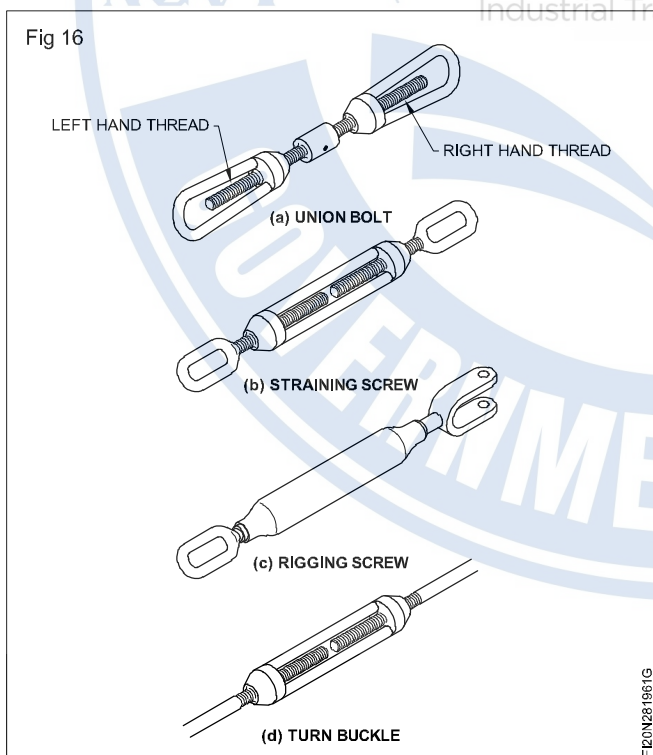

Union bolt is commonly on electrical post to keep it in erect condition. The centre part of the link is turned by tommy bar to keep the rope under tension.

Straining screw, rigging screw and turn buckle are also used in similar applications often in slinging ropes for adjusting the tension of the sling to keep the load in balanced condition.

Method of slinging

A few common methods of putting slings on the hooks have been shown in Figs 17a and 17b.

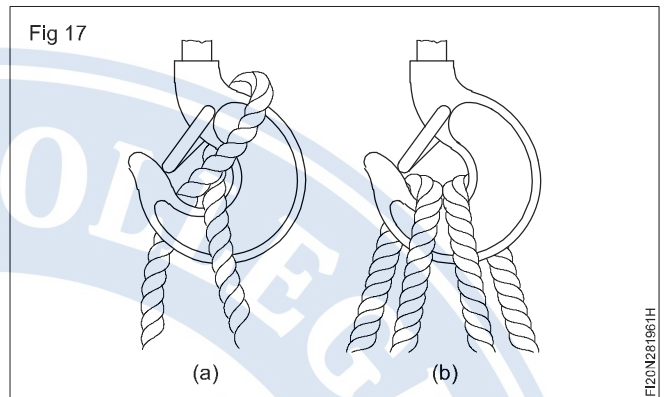

A cylindrical object slinging is shown by steel wire rope sling (basket hitch) Fig 18 which becomes automatically balanced when the slings are of equal size.

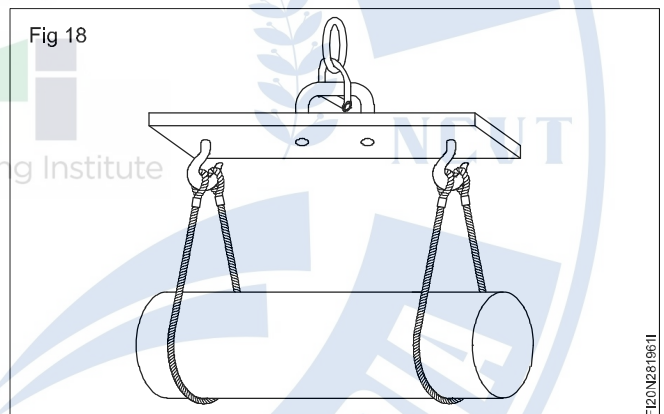
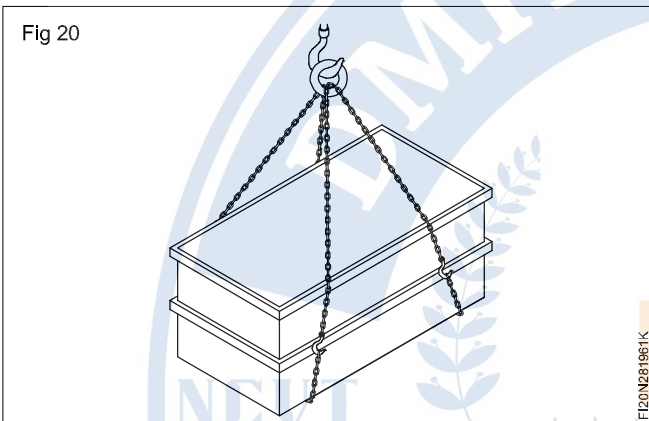
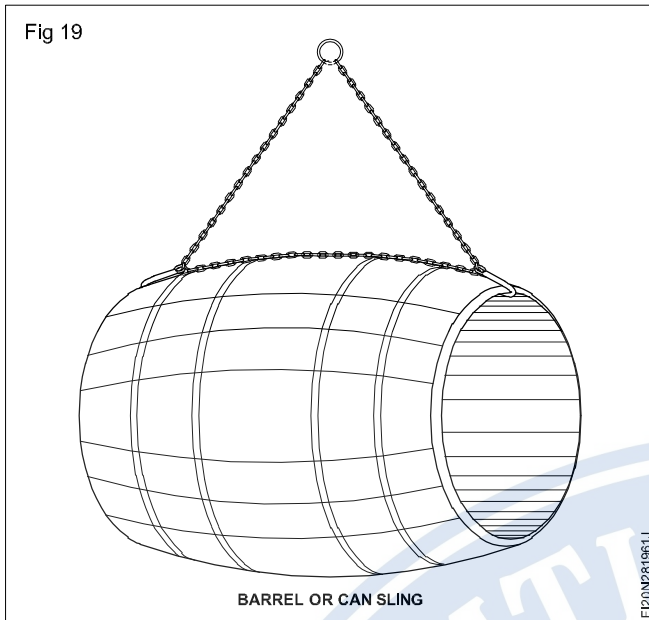

Fig 19 shows barrel slinging by chain using barrel hook. Fig 20 shows chain slinging with four legged chain sling using two endless chain wherein the object has the marking of slinging location.

Slinging methods

Wooden casing arrives at the purchaser's premises with sling marks as shown in Fig 21. The casing should be unpacked and suitable slings are made to shift to the place of installation.



Such shifting is done commonly by fibre rope slings for lighter machines and comparatively heavier machines are shifted using suitable wire rope and chain slings. Suitable packings are to be used for protecting finished surfaces of the machineries.

A few methods of slinging shaper, lathe, radial drilling machine, vertical milling and universal cylindrical grinder are shown in Fig 21 respectively.

Rigging Theory

Rigging is the action of designing and installing the equipment, in the preparation to move objects. A team of riggers design and install the lifting or rolling equipment needed to raise, roll, slide or lift objects such as with a crane or block and tackle.

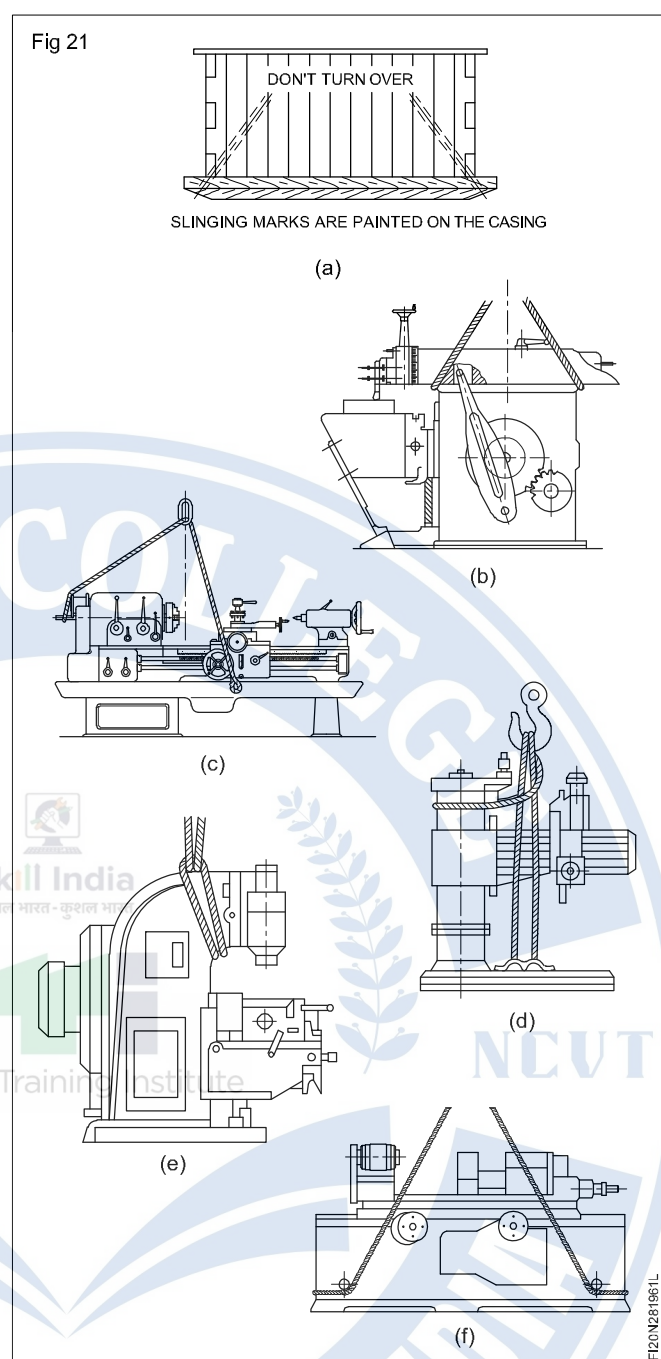

Rigging is the equipment such as wire rope, turnbuckles, clevis, jacks used with cranes and other lifting equipment (Fig 22) in material handling and structure relocation. Rigging systems commonly include shackles, master links and slings. Also, lifting bags in under water lifting.

Fig 22









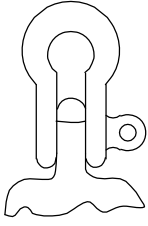
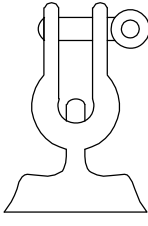
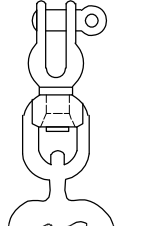
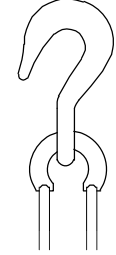
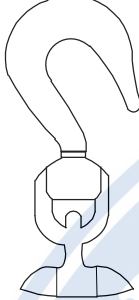
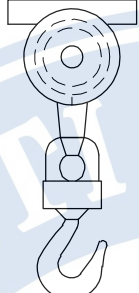
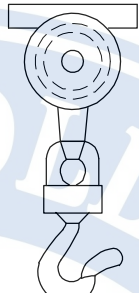
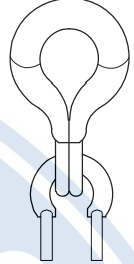
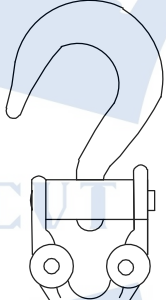
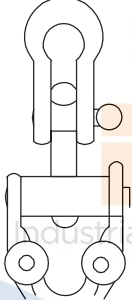
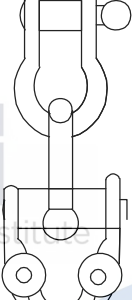
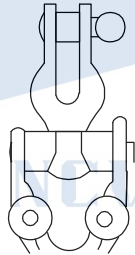

					
LOOSE FRONT REGULAR SHACKLE	LOOSE FRONT UPSET SHACKLE	UPSET SWIVEL SHACKLE IN LOOSE SIDE SINGLE HOOK	LOOSE SWIVEL LINK		
					
SINGLE SWIVEL HOOK IN LOOSE SWIVEL LINK	CRANE OR PLAIN HOOK ANTITOPPING BLOCK WITH LOOSE DISK BEARING SWIVEL HOOK	RELEASING HOOK	LOOSE SIDE SISTER HOOK		
					
STIFF SINGLE SWIVEL HOOK	REGULAR OR UPSET SHACKLE IN LOOSE SWIVEL	STIFF UPSET SWIVEL SHACKLE	STIFF UPSET SWIVEL SHACKLE		
					
REGULAR SHACKLE	UPSET SHACKLE	SINGLE AND TRIPLE WOOD BLOCK BECKET	DOUBLE WOOD BLOCK BECKET	SINGLE, DOUBLE AND TRIPLE METAL BLOCK BECKET	
					
FRONT SINGLE SHACKLE	SIDE SINGLE HOOK	FRONT SISTER HOOKS	SIDE SISTER HOOKS	SWIVEL HOOK	RELEASING HOOK

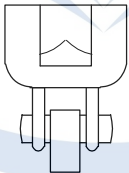
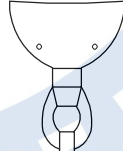
FIG2281061M

Fork lift and pallet truck

Objectives: At the end of this lesson you shall be able to

- tell about fork lift (stacker)
- mention handling load by hand pallet truck
- state advantages of moving load by stracker and pallet truck.

The fork lift is a small 4-wheel vehicle with diesel/petrol/ electrically powered engine. Heavy counter weight are fitted to the rear of the units. There are two lifting fork or arms in front of the machine which are adjustable to carry the load. They are available in various designs and capacities for shifting and stacking load in different positions.

Types

- 1 Diesel automotive fork lifter.
- 2 Battery powered fork lift stacker.
- 3 Hydraulic stacker.
- 4 Mechanical stacker.
- 5 Hand pallet truck.

1 Diesel automotive fork lifter (Fig 1)

This diesel powered truck is driven by a driver to carry loads to considerable distances to and from the shop floor/yards to work place or for storage capacity 2 tonne to 10 tonne lift 2 meter height (common).

Fork unit can be hydraulically fitted, upto 15 degrees inward or outward and lifted to desired level. (Fig 1a)

This works very efficiently to move loads faster even on rough roads. Suitably used in harbour work, in industries, ware houses. transportation between lorry and railway terminals etc.

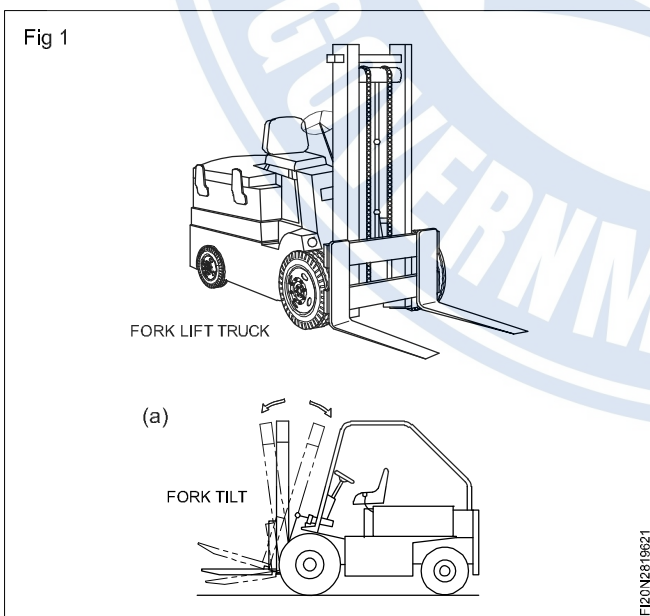

Maintenance

- Engine oil and hydraulic oils are to be changed periodically.
- Check for leakage in hydraulic cylinders.
- Cleaning and lubrication should be done to all motion parts including counter weight chain.

2 Battery powered fork lift stacker (Fig 2)

Powered fork lift stackers are compact in design and used to carry load mainly indoor within narrow space for shifting and stacking even to higher levels. The operator walks beside the truck to steer it. Lifting is done hydraulically.

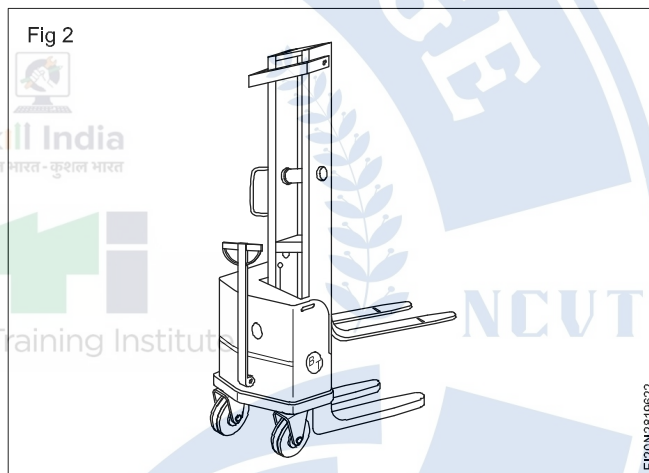

They are commonly used in workshops, warehouse, rail containers, wagons etc. capacity 500 kg-2000 kg. Lift upto 5 meter commonly used.

Maintenance

- All motion parts are to be cleaned and lubricated periodically
- Hydraulic oil should be changed (Servo System 57/ 68 as recommended) once in two years.
- Oil seals are to be changed in case of leakage.
- Distilled water should be poured in the battery as and when the level goes down.
- Battery should be charged periodically.

3 Manually operated hydraulic stacker (Fig 3)

This type of stacker is used commonly as they are cheaper and can be easily handled manually for shifting and stacking load in a limited space.

Capacity- 500 Kg to 2000 Kg.

Lift upto 5 meter.

Beneficially used in light industries, ware house etc for loading, unloading and stacking.

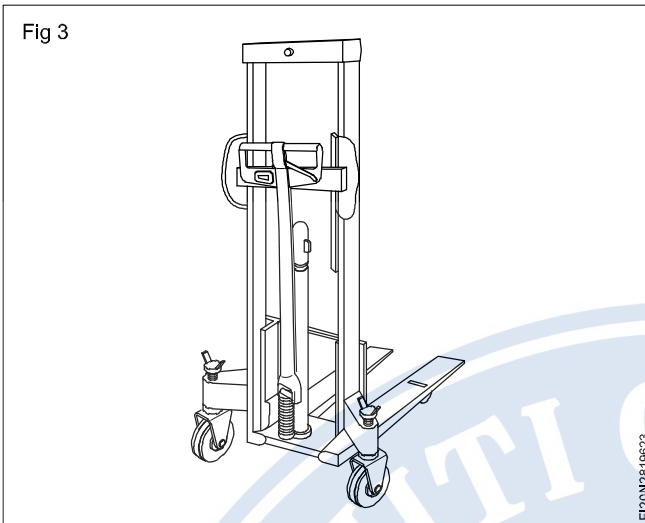

Maintenance

- Clean and lubricate all motion parts.
- Change hydraulic oil once in two years (servosystem 57 or 68 as recommended to be used)
- Replace oil seal for oil leakage.

Mechanical stacker (Fig 4)

This type of stacker is mechanically handled for moving, lifting and stacking load. These can be operated in a limited space so they are used in small scale industries.

Capacity 500 Kg.

Lift upto 2 meter.

Maintenance

- Clean and lubricate all motion parts periodically.

Hand pallet truck (Fig 5)

Pallet trucks are basically used for carrying pallet bins (Fig 5a) and other loads on floors, warehouses with high rate of turn over even bulky goods.

Types of cranes

Objectives: At the end of this lesson you shall be able to

- State basic function of crane
- mention the types of crane
- describe the application of various cranes
- state the highlights on troubleshooting
- narrate the safety on overhead crane repair.

Basic function of crane

Crane is made up of sturdy structural member of steel, which are used in Industries, Port trust etc to shift the heavy materials from one place to another place for

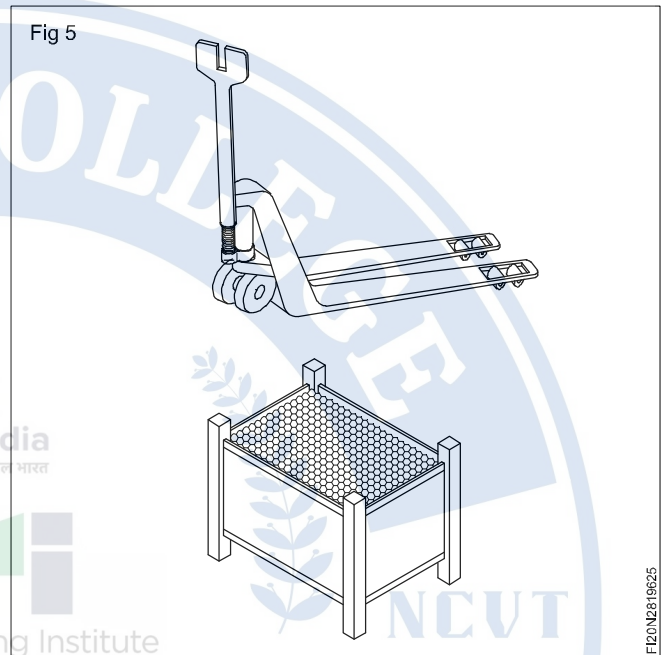
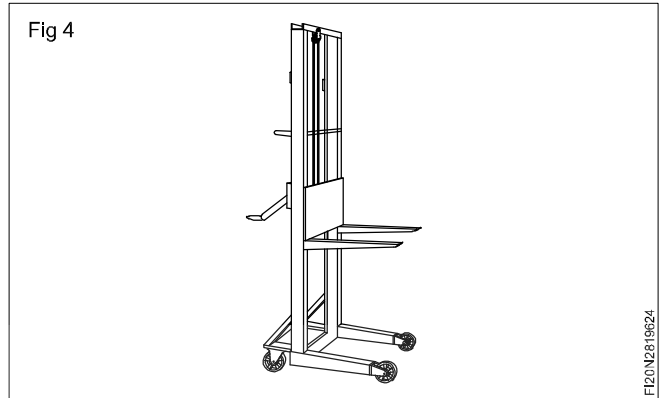

Capacity 500 kg to 2000 kg.

Maintenance

- Change hydraulic oil once in two years (servosystem oil 57 or 68 as recommended). Topup oil periodically wherever required.
- Replace oil seals in case of oil leakage.
- Clean and lubricate other motion parts periodically.

subsequent operation, assembly etc. The shape and its construction varies with application and types. There are many types of cranes are available.

Types

- Floor cranes
- Jib cranes
- Derrick cranes
- Overhead cranes
- Gantry cranes
- Travelling cranes.

Floor cranes (Fig 1a & b)

Hand operated floor cranes are used for handling light loads (up to 2000 Kg.) on the shop floor.

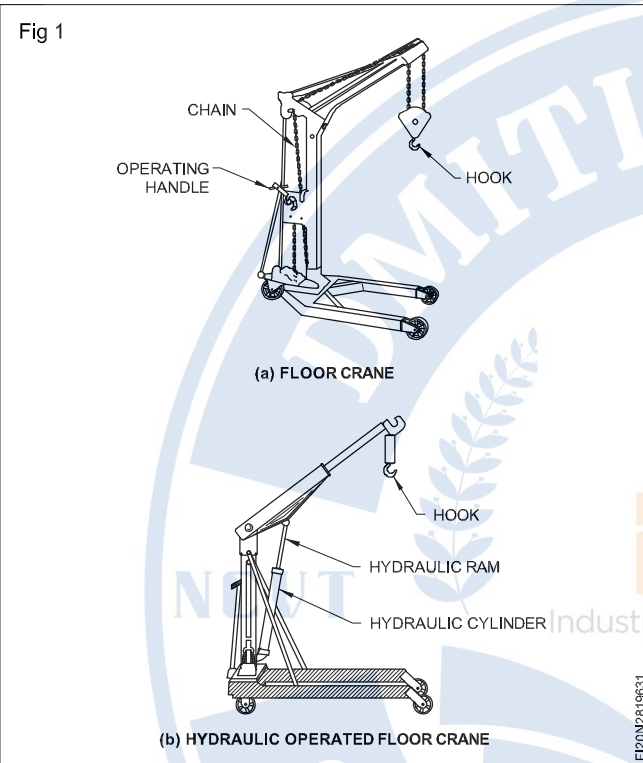

Hydraulic floor cranes are also used for lifting and shifting loads. The boom of the crane is moved up and down approximately 30° hydraulically. The boom can be extended to work for a longer reach. As the boom extends the loads carrying capacity decreases. Capacity ranges from 1000 Kg to 5000 Kg.

These floor cranes are mounted on wheels and can be moved from one place to another by pushing.

Fig 2 shows simple jib crane mounted on the strong base and supported by bearing plate at the top. The jib also called boom is supported by vertical mast with guy support at the front and stiff legs at the rear.

There are three possible movements of load i.e.

- a Raise or lower the load
- b Horizontal movement of load between mast and end of boom
- c 360° rotation of mast on its axis (slewing).

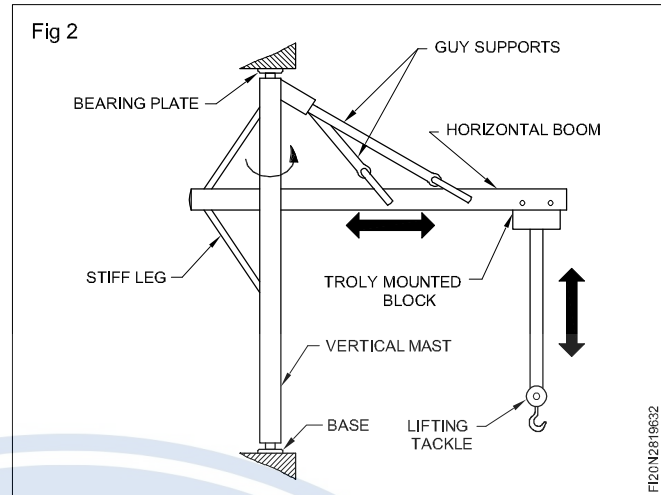

Pillar jib crane

Fig 3 shows simple jib crane. The bottom is fastened to the mast about two-thirds of the way from the base. The rear end of the boom extends beyond the mast. Boom is supported by guys from the top of the mast to provide additional support. The lifting tackle on the boom hangs from a trolley-mounted block, which slides along the length of the boom to shift the load at any position. The load can be rotated within a radius from mast.

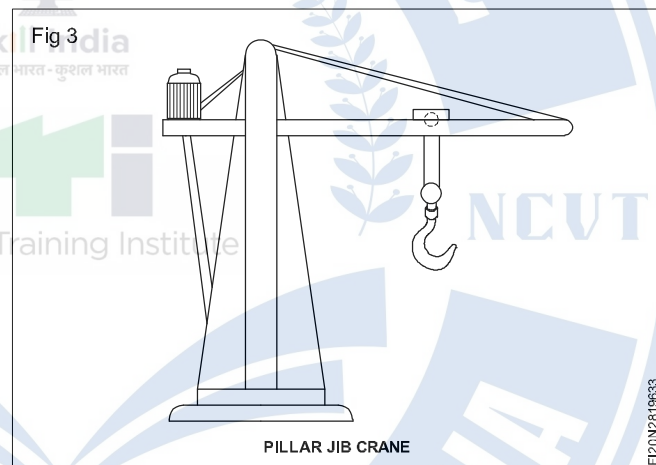
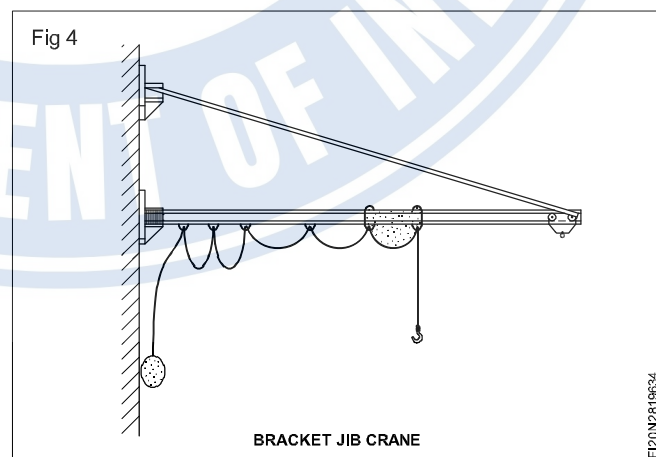

Fig 4 shows the bracket jib crane used for light load.



Derricks cranes

Gin pole derrick crane (Fig 5)

Gin pole derrick one single pole units with one end firmly secured at the base to prevent movement. It is used as a temporary hoist to raise and lower a number of light loads. In setting up a gin pole, use atleast two after guys to provide support for the working end of the pole.

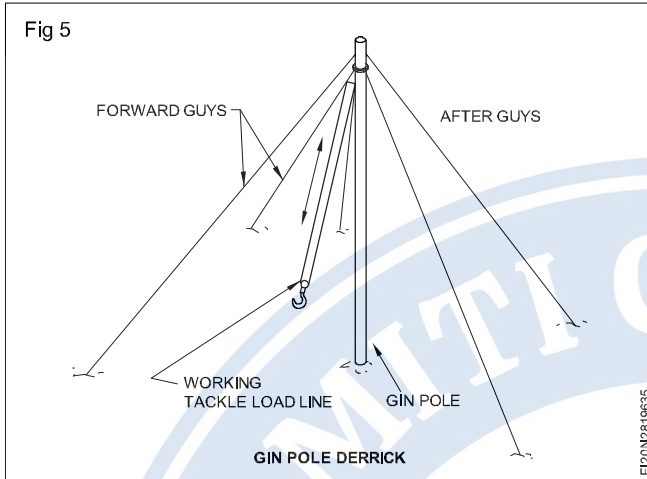

Guyed derrick crane (Fig 6)

The derricks are made of steel or wood. Derrick made of steel are mostly used. The derrick or boom is supported with mast. Mast and boom are either hand operated or power operated. The boom is rotate through bull gear, fastened at the bottom of the mast. The mast is pivoted both at bottom as well as at top. The derricks is rotated by rope passing through sheaves at the top of the bottom. Derricks of power operated by pinion meshing with gear fastened to power drive also used.

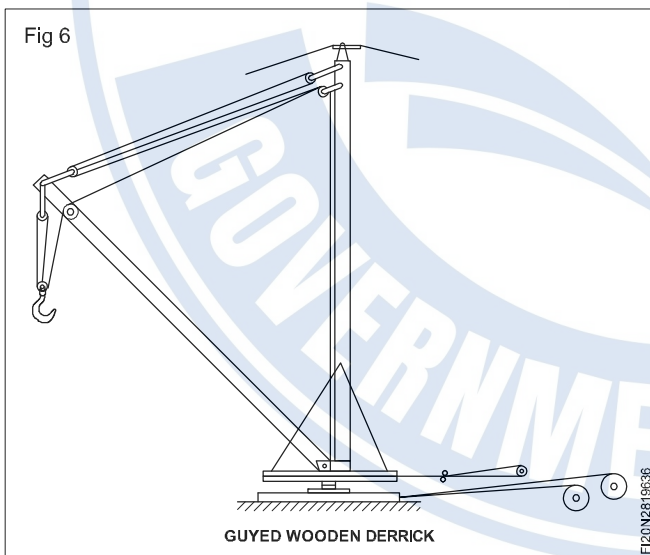
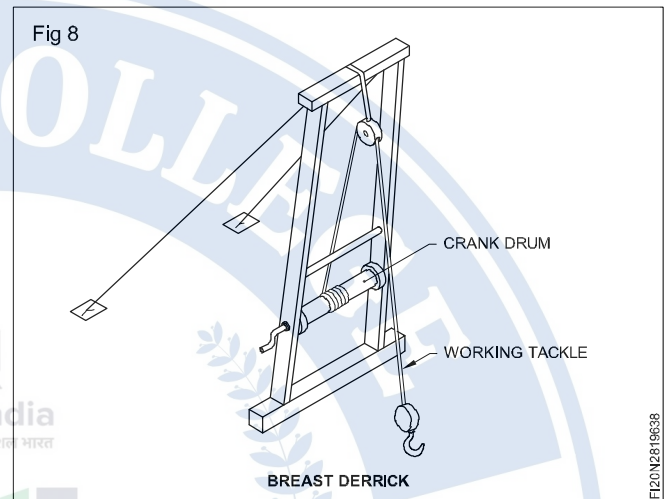
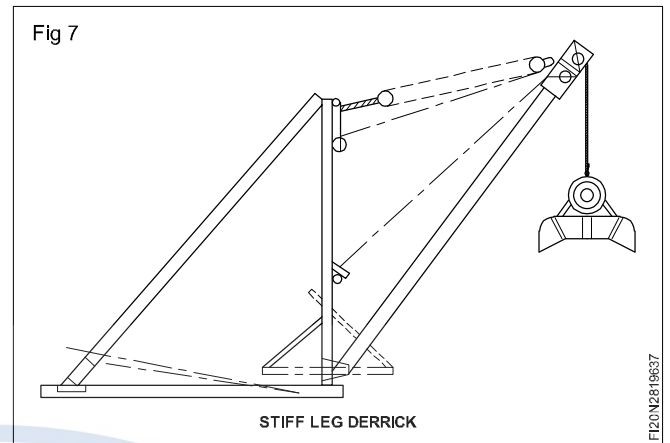
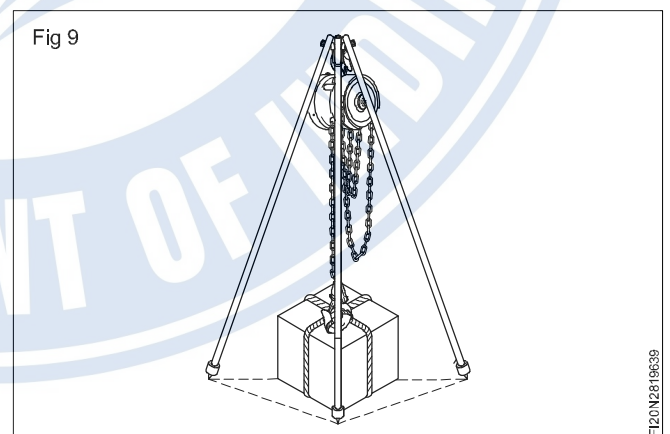

Fig 7 & 8 shows stiff leg derrick and breast derrick cranes used for matterial handling.



Tripod with chain pulley block

Each leg of the tripod is having a hole at its top end to fix up a stout bolt through 'u' shaped shackle. This bolt and shackle holds the tripod legs together at the top end and the chain pulley block can be hooked into the shackle. A nuts is screwed into the threaded end of the bolt which is riveted slightly to prevent unscrewing and coming out of nut. The bolt is kept a little loose adjust the position of three legs. (Fig 9)



Frame derrick crane

A 'frame derrick' gets its name from the shape of its main support. The main support, as shwon in Fig 10 is triangular, with the base resting on the ground or floor.

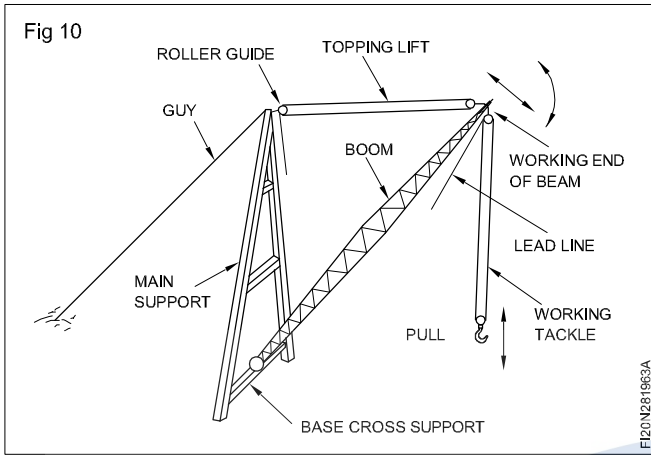

For light load frames are made of wood and for heavy duty frames are made from steel. Frames are mounted in position that prevents the base from moving or shifting under load. To operate a framed derrick, the boom or moving section, connects to a cross support at the base of the frame up-right support. The working end of the boom carries the upper block for raising the load.

Overhead crane (Fig 11)

An overhead travelling crane consists of a bridge constructed from one or several girders supporting a travelling hoist. Electrically operated overhead crane is called in short EOT crane. They are used in workshop engine rooms and in open yards to move materials to a considerable distance in fabrication and assembly works. The capacity of the crane varies from 1 tonne (light duty) to 5 tonne (heavy duty) and above depends upon the application.

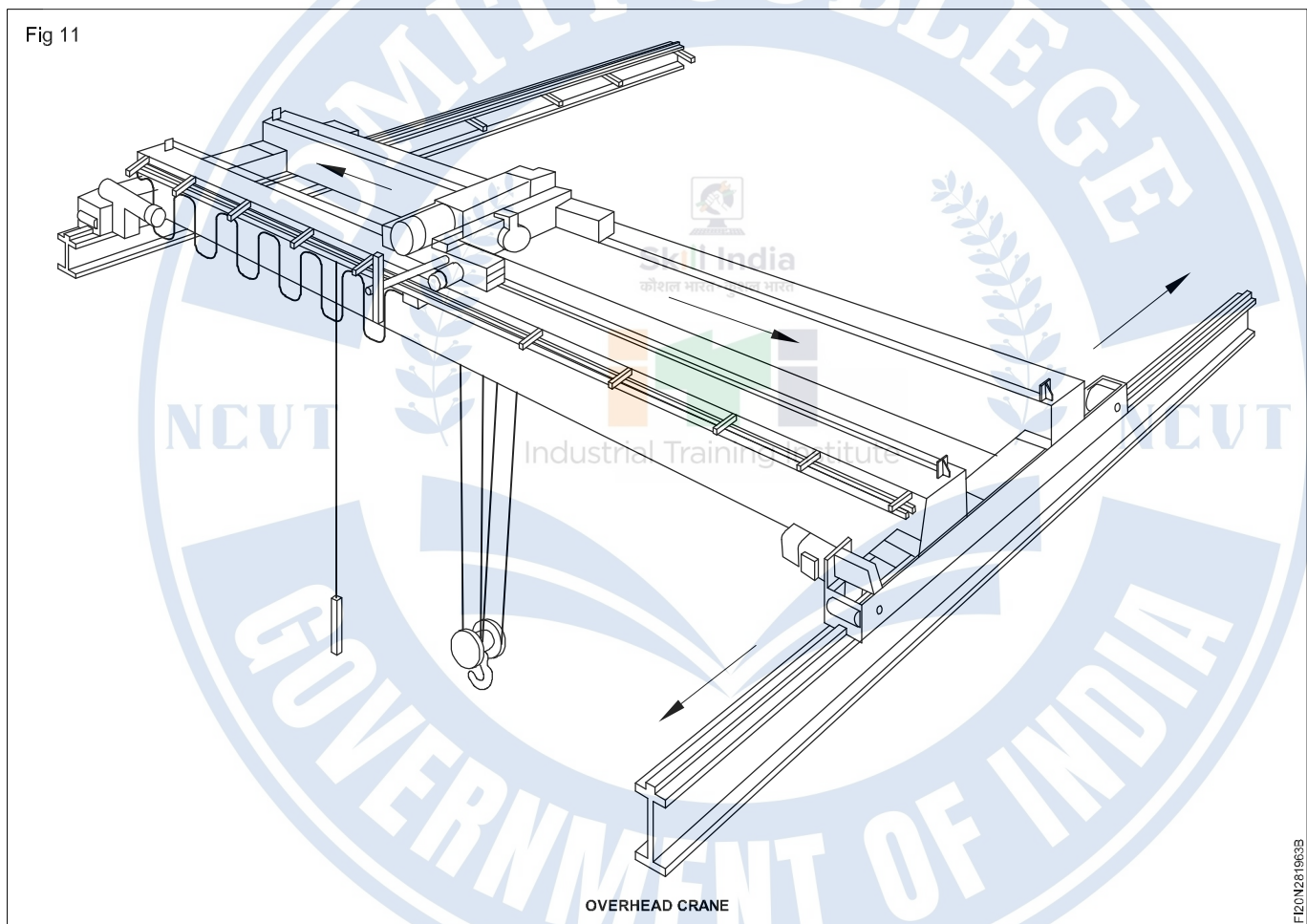

For assembling and dismantling of bulk component like diesel locomotive, carriage wagon etc. during periodical over hauling two cranes of equal capacity being used. Each crane is operated by individual certified operator. Both the operators should follow same signal at a time from the rigger. The operators sit in a cabin provided for them.

The crane normally having three individual drive are called.

- long travel
- cross travel
- hoisting

Each travel consists of individual motor drive coupled with reduction gear box. Heavy duty crane are provided with two hoisting one meant for higher load called main hoist and another one for light load called auxiliary hoist. The

capacity of the crane is written on the structural member of the crane visibly is called safe working load (SWL).

While lifting the load by crane the load do not exceed safe working load of a crane at any circumstances.

They are standard signals that every crane operator should follow while handling the load to control the crane.

While lifting load by using chain having more than one legs, ensure all the legs should have equal length.

While lifting load the structural member of the crane subjected to deflection from its position. The permissible deflection is 1mm for each 900 mm span measured at midpoint of the span by keeping the load at the centre. A crane having 9 meters span i.e. distance between two rails of long travel, the permissible deflection is 10mm.

Travelling wall crane also used in assembly shop. The long travel wheels runs on rails mounted on wheels. Fig 12 shows travelling wall crane.

Gantry crane (Fig 13)

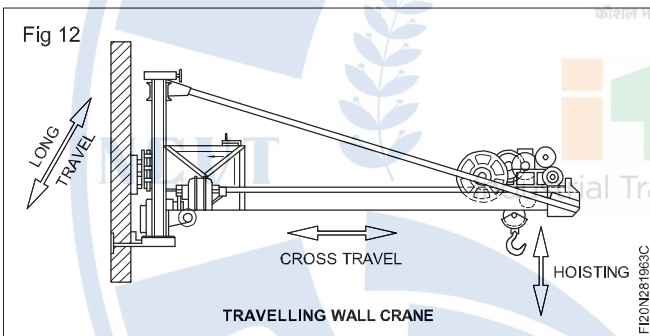

Most gantry cranes are much larger than over head

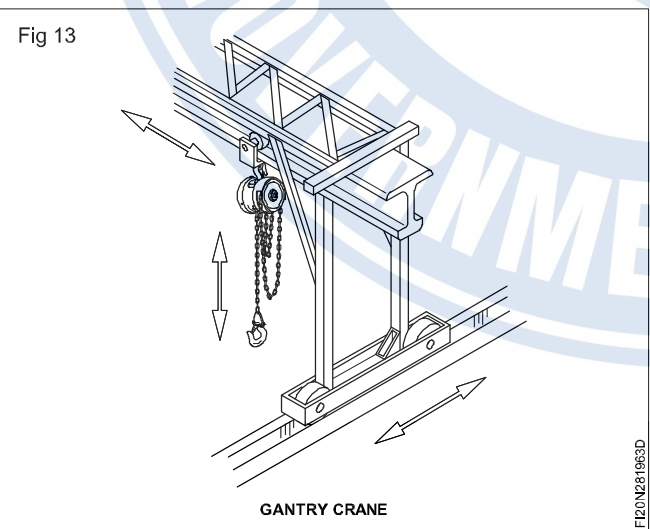

travelling cranes. It is used outside of the buildings. Gantry cranes also move on tracks, but their tracks are on the ground rather than suspended overhead. Trolleys are

mounted on two upright structures separated by the connecting bridge.

Trolley wheels support the gantry. The gantry's load movement capabilities are the same as those of the travelling crane.

Trucks mounted mobile crane (Fig 14)



There are locomotive cranes, truck-mounted cranes which are also used for lifting and moving the loads.

These crane can be used in remote places.

Problem - "The crane is not working when switched on".

When attending any repair on the overhead crane wear helmet and safety belt. The safety belt to be tied with structural member while attending repair to avoid accident by slipping.

Precautions in the removal and replacement of heavy parts

People who install or dismantle machinery and equipment could:

- Work in isolation
- Work on machinery and equipment at heights, or over machinery and equipment to connect services, such as electricity, air or water
- Work in low light, or with bright directional light
- access machinery and equipment from the top, sides or underneath
- Work with or near cranes, forklifts or rigging to lift machinery and equipment
- work in confined spaces
- use power tools, welders, extension leads, which present electrical hazards if damaged or wet.

People operating machinery and equipment could:

- be required to place their hands close to the mechanism of the machinery and equipment that does the work, and may be injured if caught or trapped by moving parts

- be exposed to constant harmful noise, radiated, energy or fumes being emitted from the machinery and equipment being operated, or are close to
- inadvertently bump or knock poorly placed control levers or buttons
- be required to make adjustments to the mechanism of machinery and equipment while the machine is in motion
- be required to clear away scrap
- make minor adjustments, or reach into the moving mechanism of the machinery and equipment being operated.

People providing maintenance or repair services could:

- work alone
- work on machinery and equipment at height, or over machinery and equipment to connect services, such as electricity, air or water
- access machinery and equipment from the rear or sides
- be required to enter confined spaces of larger machinery and equipment
- be trapped by the mechanism of the machinery and equipment through poor isolation of energy sources or stored energy, such as spring-loaded or counter-balance mechanisms, compressed air or fluids, or parts held in position by hydraulics or pneumatic (air) rams

- Move heavy parts when changing the set up of machinery and equipment, or repairing failed parts, such as electric motors or gear box assemblies
- disable or remove normal safety systems to access the mechanisms of machinery and equipment.

People providing cleaning services could:

- work alone
- access machinery and equipment from the rear or sides, or in unexpected ways
- climb on machinery and equipment
- enter confined spaces, or larger machinery and equipment
- become trapped by the mechanism of the machinery and equipment through poor isolation of energy sources or stored energy, such as spring - loaded or counter - balance mechanisms, compressed air or fluids, or parts held in position by hydraulics or pneumatic (air) rams
- work with chemicals
- operate electrical equipment in wet areas.

